

PRODUCT CATALOGUE

OIL, GREASE & FUEL EQUIPMENT | HOSE REELS | FLOW METERS



GREASE EQUIPMENT

Manual Grease Guns	14-16
Air Operated Grease Guns	17
Battery Operated Grease Gun	18
Manual Grease Pumps	19-21
Air Operated Grease Pumps	22-29
Grease Accessories	30-39

OIL EQUIPMENT

Battery Operated Pumps	40-43
Manual Oil Pumps	44-49
Air Operated Oil Pumps	50-51 / 54-55
Air Operated Oil Pump Packages	52-53 / 56-61
Air Operated - IBC Systems	62-65
Oil Control Guns	66-67 / 70-71
Oil Control Guns - Metered	68-69 / 72-73
In-Line oil Meters	74-75
Oil Accessories	76-77

FUEL EQUIPMENT

Manual Fuel pumps	78-81
Electric Fuel Pumps	82-87
Air Operated Diaphragm Pumps	89
4 Way Evacuation Valves	90
Fuel Equipment Systems	92-95
Mechanical Fuel Meters	96
Digital Fuel Meters	97
Industrial Flow Meters	98-99
Fuel Accessories	100

METAL HOSE REELS

Grease	101-102
Oil/Diesel	103
Air/Water	104
Bare Reel (No hose)	105



HOSE REELS

R3 Series RetractableFlex Reels	111
R3 Series Compressed Air Reels	113
R3 Series Air/Water Reels	115
R3 Series Hot Wash Reels	116
R3 Series Cold Water Reels	117
R3 Series High Pressure Water Reels	118
R3 Series Garden/Horticultural Reels	119
R3 Series Oil Reels	120
R3 Series Grease Reels	122
R3 Series Welding Gas Reels	124-127
R3 Series Chemical - Weed /Pesticide Reels	128
R3 Series Coolant Reels	129
R3 Series FRAS Air/Water Reels	130
F Series Heavy Duty Pedestal Reels	132
F Series Heavy Duty Cradle Reels	134
F Series Heavy Duty Pedestal Reels -Metered	136

HOSE REELS

F Series Heavy Duty Cradle Reels - Metered	137
E Series Enclosed Metal Reels	138
H Series AD Blue Reel	139
Retracta Capability Statement	140



GREASE EQUIPMENT

Manual Grease Guns	144-145
Air Operated Grease Guns	146
Battery Powered Grease Guns	147-148
Air Operated Grease Systems	149
Grease Accessories	150-151
Grease Nipples	152-154

OIL EQUIPMENT

Manual Oil Pumps	155-157
Air Operated Oil Pumps	158
Air Operated Oil Pump kits	159-160
Mobile Oil Evacuation Systems	161
Oil Equipment Systems	162-163
Electric Oil Pump	164
Digital Preset Oil Guns	165
Oil Control Guns	166-171
Oil Bar Taps	172
Digital Oil Meters	173
Waste Oil Equipment	174-175
Truck Oil Drainers	176
Oil Accessories	177

FUEL EQUIPMENT

Manual Fuel Pumps	178-179
Battery Operated Drum Pumps	180-181
Electric Fuel pumps	182-184
Fuel Meters	185
Fuel Nozzles	186-187
Air Operated Diaphragm Pumps	188
Fuel Accessories	189

ADBLUE®/DEF/UREA EQUIPMENT

AdBlue® and Specialty Pumps	190-191
AdBlue® Nozzles	192
AdBlue®/DEF Electric Pump	193
AdBlue® Meters	194
AdBlue® Accessories	195

HOSE REELS

Metal Hose Reels	196-198
Hose Reels	199

TECHNICAL

Service Parts	200-247
Product Category Index	248-261
Warranty Terms & Conditions	262



macnaught

BUILT TO LAST SINCE 1948

Proudly Australian

Based in Sydney, Macnaught is a success story in Australian innovation on the world stage. For more than 70 years, we have designed and manufactured high-quality fluid and lubrication equipment for agricultural, industrial, automotive, transport and mining industries. Today, our range of hose reels, flow pumps, meters and accessories for grease, oil and fuel are distributed in more than 60 countries worldwide.

The Macnaught difference

Since the beginning, our vision has been to offer professionals absolute reliability and uncompromised performance in the harshest environments. Over time, we have made this vision a reality and have become the benchmark in our class thanks to our DNA of:

- Innovative designs,
- Quality workmanship and,
- An expert team dedicated to your business.

We also offer up to 10-years' mechanical warranty and guaranteed parts availability on Macnaught-designed products.

We call this the **Macnaught difference**; our customers call it **peace of mind**.

WE ARE WITH YOU



Macnaught global office locations

60+

Countries



2, 500

Product lines



4, 500

Products sold weekly



1, 500

Items delivered daily



10yr

Up to 10 years warranty on
Macnaught designed products



Support

In house customer service
and technical team



WHAT SETS US APART

As your needs evolve, Macnaught is there right alongside you to deliver outstanding product reliability and peace of mind.

INNOVATION

Our unique designs lead the field in quality and performance. We listen to our customers to understand their changing requirements and design innovative solutions to improve performance and durability.



MACNAUGHT
INNOVATION

TECHNICAL EXPERTISE

Our engineers are backed by more than 70 years' experience designing and manufacturing world-class products that meet exacting specifications and tolerances. That experience translates to unflinching performance when it counts in the field and expert technical support when you need it.



TECHNICAL
EXPERTISE

CUSTOMER SERVICE

Our customer service network of highly trained, local representatives ensures that you receive fast and informed support to help your business succeed.



CUSTOMER
SERVICE

CORE PRODUCT CATEGORIES

GREASE
EQUIPMENT



OIL
EQUIPMENT



FUEL
EQUIPMENT



HOSE
REELS



POSITIVE
DISPLACEMENT
FLOW METERS



KEY BRANDS



AUSTRALIAN MANUFACTURED

Since 1948, Macnaught has produced millions of products from its factory in Sydney, New South Wales. Our local operation provides us with a competitive advantage that benefits our customers through best-in-class products, service and advice. At the same time, we are proud to contribute to the Australian economy through highly skilled jobs, a commitment to quality and environmental standards, and opportunities for Intellectual Property development.

IN-HOUSE ENGINEERING TEAM

Supporting our product innovation with:

- Agility to meet customers' needs quickly and precisely
- Constant customer contact enables novel solutions to new challenges



LOCAL MANUFACTURING

As a proud manufacturer for over 70 years, we provide:

- Local employment, training and development
- Quality No.1 backed by up-to 10 years' Macnaught warranty



OUR COMMITMENT TO QUALITY & THE ENVIRONMENT

Our high quality and service guarantee is backed by :

- ISO 9001 certified for commitment to high-quality products and services
- SO 14001 certified for commitment to environmental management



AUSTRALIAN OWNED

As an Australian-owned company, Macnaught invests in local infrastructure to support our domestic and global customers to the highest level. This includes an unrivalled warehouse and logistics network and a Customer Service Team dedicated to your needs.

IN-HOUSE CUSTOMER SERVICE

Located at our Head Office in Sydney, our skilled Customer Service Team makes it their business to know your business and help you grow. When you place an order through our simple yet sophisticated ordering system, the team is there to assist, including making possible same-day dispatch for orders entered prior to 12:30pm Australian Eastern Standard Time.

A/NZ SALES AND DISTRIBUTION NETWORK

Dealing with Macnaught is made easy thanks to sales representation in all states and territories across Australia and New Zealand. Backed by our robust distribution network – with centres on the east and west coasts of Australia and New Zealand – our sales team can respond quickly when you need them.

NATIONAL SALES TEAM & DISTRIBUTION NETWORK

Macnaught has sales representatives in all states and territories across Australia and New Zealand. Supporting our sales team is our integrated distribution network with warehouses on the east and west coasts of Australia and New Zealand.

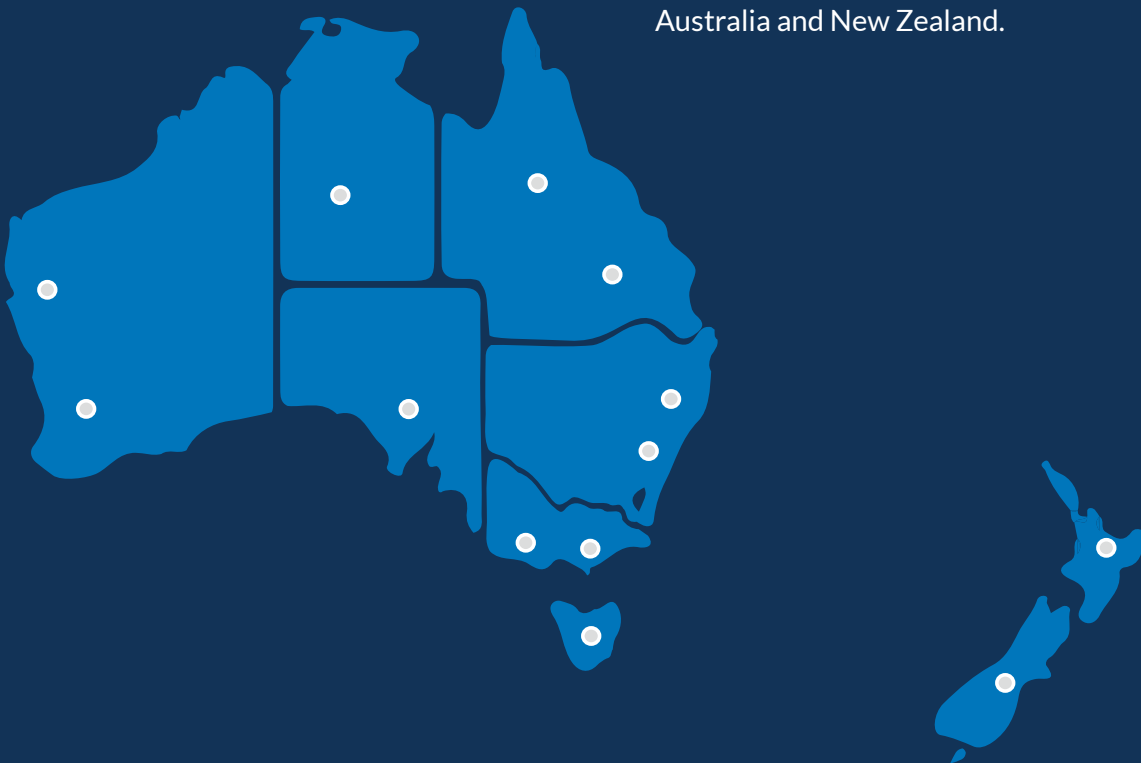

MARKETS WE SERVE

Since the beginning, our vision has been to offer professionals absolute reliability and uncompromised performance in the harshest environments. Over time, we have made this vision a reality and have become the benchmark in our class.



Agriculture

- Farm-ready grease, oil, air and fuel handling products
- Robust construction, reliability and longevity

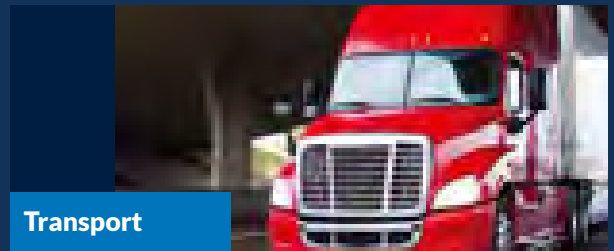

Transport

- Innovative engineering and technology solutions for high-volume oil and grease delivery systems
- Passenger and freight applications

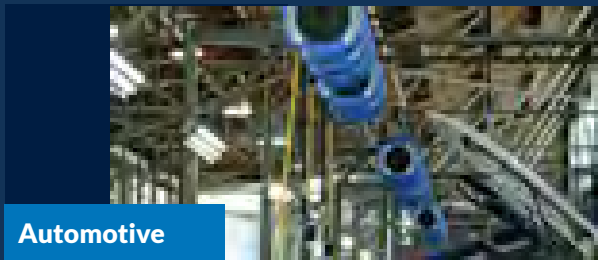

Automotive

- Products and systems for workshops across oil, grease, compressed air, water and other fluids.
- Includes portable oil systems, trolleys, oil control guns, hand-operated fuel pumps and electronic fluid management systems



Industrial

- Advanced in-house machining capability
- Strong presence in bitumen production, desalination, water treatment and the ever-critical fuel flow and lubrication management in civil construction



Mining

- Greasing equipment designed and manufactured to handle Australia's harshest environments
- The global choice for both underground and open-cut mines
- Efficient, modern fluid-management equipment and environmental technologies



Aviation

- Applications specific products for clean and accurate lubricant handling
- Precision, pressure controlled lubricant dispensing equipment



Manufacturing

- Diverse applications require adaptable and durable fluid handling equipment.
- Accuracy and repeatability of equipment affords control over process



Marine

- Portable battery operated pumps and other equipment for confined areas and ease of access.
- Hose reel products in Stainless Steel for corrosion protection

LOGISTICS SERVICES



Macnaught provides a market-leading warehouse and logistics network that supports its domestic and global customers. With a simple yet sophisticated ordering system supported by our dedicated Customer Service Team, we provide same-day dispatch for orders entered prior to 12:30pm Australian Eastern Standard Time.



Find what you need

- Stock availability
- Exclusive online promotions
- Reseller pricing



Place your order

- Order confirmation
- Order status and history
- Order now, pay later



Deliver anywhere

- Deliver tracking
- Ship directly to your customers

MARKETING RESOURCES

POINT OF SALE STANDS

In-store display stands to support Macnaught, Retracta and Lubemate products.

Large Macnaught multi-brand Stand - (code: MP101)

Small Macnaught multi-brand Stand - (code: MP102)

Retracta R3 Series Reel stand - (code: MP8)

Macnaught Poly Diesel Tank Stand - (code: MP52)

Please see your local
Macnaught Sales Representative
for ordering details.

MP101
H: 2, 200
W: 900
D: 565

MP8
H: 1, 400
W: 915
D: 600

MP52
H: 1, 720
W: 860
D: 550

MP102
H: 1, 380
W: 900
D: 565

H: 600
W: 600



COUNTER READY DISPLAYS

Available in-store display counter stands for our grease couplers.

KY+ 10 pack metal display with 7" LCD Screen - (code: MP112)

KY+ 10 pack Cardboard carton display - (code: KYPLUS-01-10 (BSP thread), KYPLUS-02-10 (NPT thread) and KYPLUS-03-10 (M10X1 thread))

Lubemate long and short nose coupler metal stand - (code: L-QRC-KIT2)

Please see your
local Macnaught
Sales Representative
for ordering details.

MP112

KYPLUS-01-10

L-QRC-KIT2



ONLINE RESOURCES

MACNAUGHT E-COMMERCE WEBSITE

www.macnaught.com.au

The main website for all Macnaught product information and resources. Also works as an e-commerce platform for Macnaught distributors. To purchase product for reselling use, please register to become a channel partner with Macnaught. To register go to au.macnaught.com/register



**FASTER, SIMPLER
AND MORE
CONVENIENT WAY
TO DO BUSINESS**

Available exclusively to Macnaught Distributors, your online access provides you with a faster and more convenient way of doing business.

MACNAUGHT MARKETING RESOURCE CENTRE

www.macnaughtmrc.com.au

The one-stop-shop for all Macnaught marketing collateral to support our Channel Partners. This includes product images, data sheets, instruction manuals, logos and brochures. Channel Partners can register online for access.





PORT AUSTRALIAN



MACNAUGHT IN THE INDUSTRY

Macnaught specialises in lubrication and fluid handling equipment. From traditional manual oil pumps, to innovative, patent approved technology in our Battery Operated oil pump range - Macnaught shows the test of time.

Serving markets such as agriculture, transport, mining, industrial, aviation and marine, with full suites of products and accessories; Macnaught ensures you get the job done right.

Our premium brand encompasses Australian manufactured and designed equipment for grease, oil and fuel as well as hose reels and flow meters, that are exported and distributed to more than 60 countries.

Macnaught strives to encompass innovation in all that we do; our patent approved products are testament to our innovation by design logic. This is what sets us apart from our competitors and gives our customers confidence backed by our 10 year* mechanical warranty and guaranteed parts availability.

MANUAL GREASE GUNS

K29/K32 FLEXIGUN® 450g & 400g

The Macnaught FLEXIGUN® pistol grip grease gun is best in class for design, performance and reliability. The heavy duty construction and unique short stroke function provides the means to develop pressures up to 10,000psi.

10
YEARS
MACNAUGHT
WARRANTY*

Develops
up to
10,000
psi

Filler bleeder

Open it by hand, no tools

Machined barrel thread

Makes it easier to screw to the head

KY SUPERGRIP™

3 jaw high pressure coupler for positive connection

KF9 Flexible Grease Extension

300mm (12")

Stepped barrel

For easy grip

Screw fasteners

For easy servicing, no rivets

Lock follower rod

For easier bleeding

9mm diameter hand operated Filler / Bleeder Outlet

For use with Macnaught J3 grease pump or any other 9mm bulk fill grease pump

Heavy duty

1.6mm thick barrel

Robust

Zinc pull handle



K29-01

Why choose this product?

- One handed high pressure greasing

Service Parts

- **K29-1K:** Service Kit (450g/400g)
- **K27-2K:** Follower Kit (450g)
- **KF14A-2K:** Follower Kit (400g)

Applications:

Suitable for use in all greasing applications

K29/K32 FLEXIGUN® 450g & 400g



K29-01



K29-01-11



K32-01

Part Number	K29-01	K29-01-11	K32-01
Description	FLEXIGUN® 450g	FLEXIGUN® zinc	FLEXIGUN® 400g
KY SUPERGRIP™ coupler	✓	✓	✓
Flex extension	300mm (12")	300mm (12")	300mm (12")
Typical output pressure range*	34, 500 - 68, 900kPa (5, 000 - 10, 000psi)		
Output volume per shot	0.68g	0.68g	0.68g
Cartridge	450g (16oz)	450g (16oz)	400g (14oz)
Bulk fillable	✓	✓	✓
Max grease type	NLGI No.2	NLGI No.2	NLGI No.2
Wetted Parts	Aluminium, steel, nitrile rubber, cork and nylon. (Note- Zinc replaces Aluminium on K29-01-11)		



K29-12

Part Number	K29-12	FGK1-01	FGK1-02
Description	K29 in case with Cartridge	K29 in case with accessories & cartridge	K32 in case with accessories & cartridge
FLEXIGUN® model	K29-01	K29-01	K32-01
Robust blow moulded case	✓	✓	✓
KY SUPERGRIP™ coupler	✓	✓	✓
450g (16oz) grease cartridge	✓	✓	✓
KIN hypodermic injector needle coupler	✗	✓	✓
KZDXL straight needle point coupler	✗	✓	✓



FGK1-01 (WITH K29)
FGK1-02 (WITH K32)

Recommended to be used with:



KYPLUS-01
Grease Coupler
(Page 31)



ACK2-02
Aviation Kit
(Page 34)



KZDXL
Long Needlepoint
Coupler (Page 36)



J3-01
Bulk Fill Grease Pump
(Page 19)



PRV-25
Pressure Relief Valve
(Page 38)

MANUAL GREASE GUNS

K45/K40 LEVERGUN® 450g and 400g

Designed for high pressure, high volume greasing, this lever action grease gun can easily clear blocked or damaged grease nipples.

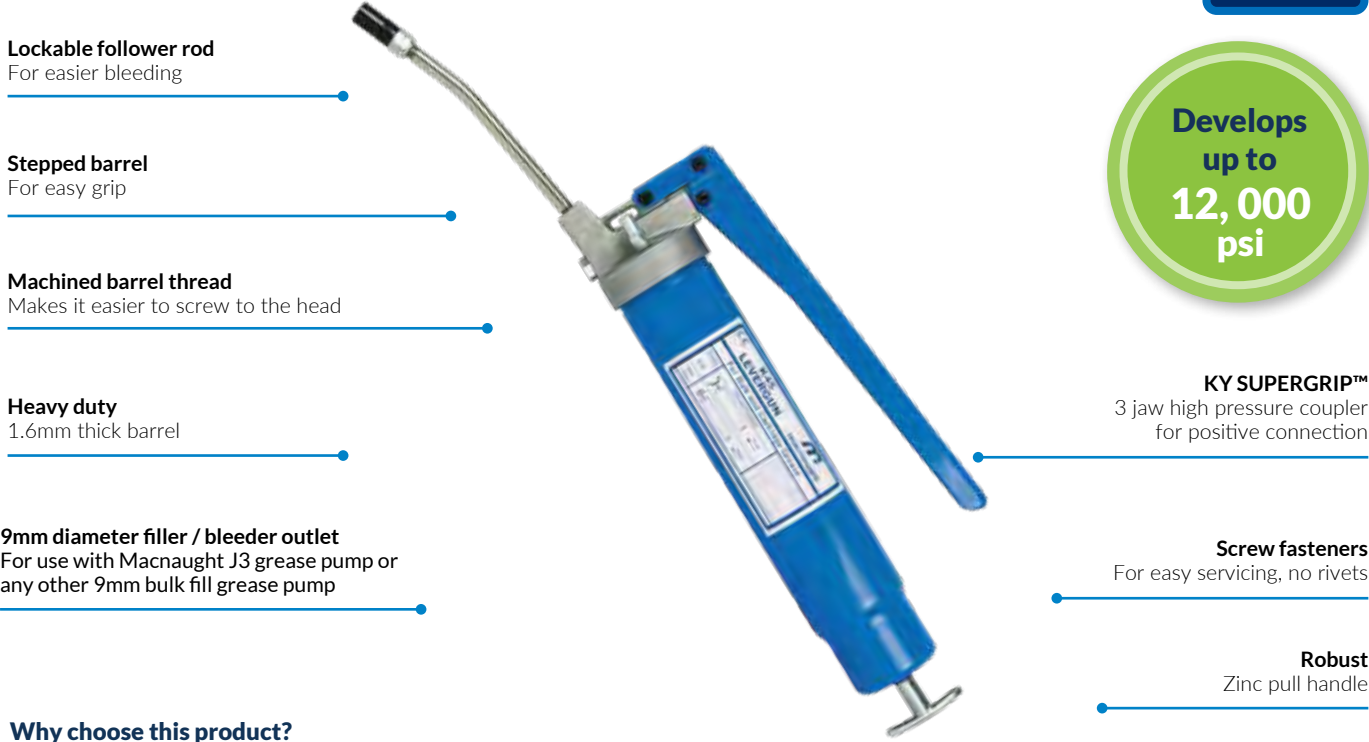

Lockable follower rod
For easier bleeding

Stepped barrel
For easy grip

Machined barrel thread
Makes it easier to screw to the head

Heavy duty
1.6mm thick barrel

9mm diameter filler / bleeder outlet
For use with Macnaught J3 grease pump or any other 9mm bulk fill grease pump

KY SUPERGRIP™
3 jaw high pressure coupler for positive connection

Screw fasteners
For easy servicing, no rivets

Robust
Zinc pull handle

Why choose this product?

Easy two hand high pressure greasing

K45-01

Part Number	K40-01	K45-01	K45-01-11
Description	K40 LEVERGUN® 400g Grease Gun	K45 LEVERGUN® 450g Grease Gun	K45 LEVERGUN® 450g Zinc Gun
KY SUPERGRIP™ coupler	✓	✓	✓
Included Extensions	150mm (6") rigid & 300mm (12") flexible		
Typical output pressure range*	48,300 – 82,750 kPa (7,000 – 12,000psi)		
Output volume per shot	1.5g	1.5g	1.5g
Cartridge	400g (14oz)	450g (16oz)	450g (16oz)
Bulk fillable	✓	✓	✓
Max grease type	NLGI No.2	NLGI No.2	NLGI No.2
Wetted Parts	Aluminium, steel, nitrile rubber, cork and nylon. (Note- Zinc replaces Aluminium on K45-01-11)		

Service Parts

- **K45-1K:** Service Kit 450g/400g
- **K27-2K:** Follower Kit 450g
- **KF14A-2K:** Follower Kit 400g

Applications:

Suitable for all type of greasing applications

Recommended to be used with:



KYPLUS-01 Grease Coupler (Page 31)



KZD Needleless Coupler (Page 36)



KF30 Rigid/Flexible extension (Page 37)



J3-01 Bulk Fill Grease Pump (Page 19)



KIN Grease Injector Needle (Page 37)

AIR OPERATED GREASE GUN

K53 POWERPISTOL™ 450g Air-operated Grease Gun

The K53 POWERPISTOL™ is an air-powered single shot grease gun that combines portability with effortless one handed operation. Low air consumption makes the K53 POWERPISTOL™ ideal for use with truck and bus brake system air supply. Heavy duty pistol grip construction with comfortable ergonomics to suit 450g grease cartridges, bulk filling or Macnaught J3 grease transfer pump loading. The K53 POWERPISTOL™ is fully repairable with a strong die cast head and heavy gauge steel barrel for extra long service life.

10
YEARS
MACNAUGHT
WARRANTY*

Flexible 300mm (12") extension
With KY SUPERGRIP™ coupler for positive connection

Fully repairable
Provides a much longer service life

Low air consumption
Use with truck & bus brake system air supply

Heavy-duty design and construction
Reduces wear

Lock the plunge rod into the follower
For easier bleeding

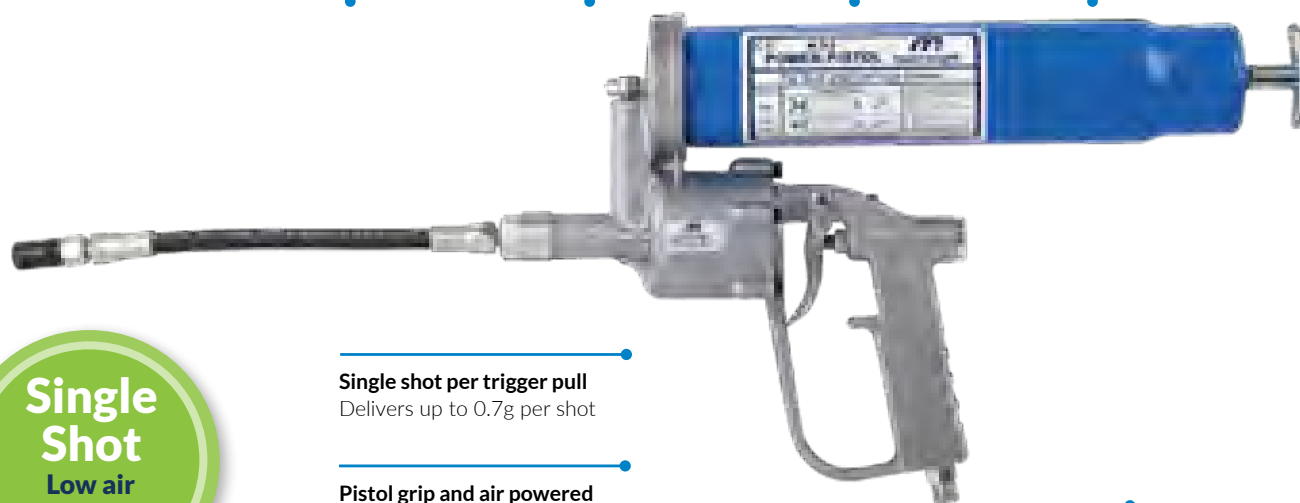

Single shot per trigger pull
Delivers up to 0.7g per shot

Pistol grip and air powered
For easy one handed operation

450g Grease cartridge or bulk fill
Economical & contamination free greasing from 450g grease cartridge or bulk fill from J3 grease pump

Stepped barrel
For easy grip

Part Number	K53-01
Description	K53 POWERPISTOL™ Air Operated Grease Gun
KY SUPERGRIP™ coupler	✓
Extension	300mm (12") flexible
Max output pressure	41, 400 kPa (6, 000 psi)
Output volume per shot	0.7g
Recommended air pressure	620 kPa (90 psi)
Max air pressure	830 kPa (120 psi)
Min compressor size	0.026 m3/min (1 cfm)
Air inlet	1/4" BSP (M)
Cartridge	450g (16oz)
Bulk fillable	✓
Max grease type	NLGI No.2
Wetted Parts	Aluminium, steel, nitrile rubber, cork and nylon

Why choose this product?

Low air consumption

Service Parts

- K53-1K: Service Kit
- K27-2K: Follower Kit (450g)

Applications:

Suitable for all type of greasing applications

Recommended to be used with:



KYPLUS-01
Grease Coupler
(Page 31)



KZD
Needlenose Coupler
(Page 36)



KFR
Rigid/Flexible
extension (Page 37)



KZHY Hypodermic
Needlepoint Coupler
(Page 36)



KF300-1K
400G Conversion Kit
(Page 39)

BATTERY POWERED GREASE GUN

PG450 POWERGUN™ High Performance Li-Ion Grease Gun

The POWERGUN™ 18V Li-Ion battery powered grease gun built with the demanding Australian conditions in mind. This powerful heavy duty grease gun is portable, durable and can move grease quickly or at high pressure via the high/low volume valve. The POWERGUN™ includes a smart carry case with a spare 18V Li-Ion battery for added longevity and portability and a 1 hour fast charger for continuous operation.

2
YEARS
MACNAUGHT
WARRANTY*

POWERGUN™

2
Batteries
Included

18V Lithium-Ion battery
Lightweight, long life for continuous pumping

SUPERGRIP™ KY Coupler
Leak free connection

Ergonomic design
With stable free-stand capability



LED light
To light dark areas and locate grease ripples

Spring loaded bleeder valve
To simplify new cartridge bleeding

1m long flexible extension
To reach hard to get grease nipples

Part Number	PG450
Description	POWERGUN™ 18V Battery Operated Grease Gun
KY® High Pressure Grease Coupler	✓
Included	2 x 3.0Ah Li-Ion batteries 1 x 90 minute fast charger 1m flexible hose Shoulder strap
Typical output pressure range	58, 600kPa (8, 500psi)
Output volume per shot	150g/min
Cartridge	450g (16oz)
Max grease type	NLGI no 2
Wetted Parts	Aluminium, mild steel, nitrile rubber

Why choose this product?

Reliable continuous greasing

Service Parts

- K27-2K: Follower Kit
- PGC-3A: PG450 Spare Battery Charger(3.0Ah)
- PGB-3A: PG450 Spare Battery(3.0Ah)
- PGH: PG450 Grease Hose 1 meter

Applications:

Suitable for all type of greasing applications

Recommended to be used with:



KYPLUS-01
Grease Coupler
(Page 31)



KZHY Hypodermic
Needlepoint Coupler
(Page 36)



KZDXL
Straight Needlepoint
Coupler (Page 36)



KDF13, KDF21, PF17,
PF30 - Suitable Flexible
Extensions
(Page 37)

MANUAL GREASE PUMPS

K4 SUPERLUBE™ Portable High Pressure Greasing System

Designed to offer powerful and professional greasing with robust portability, SUPERLUBE™ products incorporate a spring loaded priming system to feed the KR PRESSURITE™ grease gun. This system is designed for those applications where compressed air is unavailable but bulk grease is preferred.



J3 Bulk Fill Grease Pump (for FLEXIGUN® & LEVERGUN®)

An economical solution for refilling most standard grease guns from larger bulk pails. The standard J3 fills Macnaught's range of hand, air powered guns and MINILUBE® KT5 and KT6 containers.



KY SUPERGRIP™ Coupler
Positive leak free connection

Sliding bung adaptor
Allows several different grease pails to be covered by one single model

Rubber edged follower plate
Prevents air pockets and contamination



Leak free connection
Rigid extension with filler nozzle provides a leak free positive connection

J65 bulk fillable nozzle
Rigid extension

Adjustable collar system
To accommodate different height grease pails up to 20kg

Part Number	K4-01	J3-01
Description	K4 SUPERLUBE™ Portable Manual Greasing System	J3 Grease Transfer Pump
KR PRESSURITE™ dual pressure grease gun	✓	X
Pail size	18-20kg (44lb)	18-20kg (44lb)
Typical output pressure from KR PRESSURITE™ grease gun*	34,450 – 68,900kPa (5,000 – 10,000psi) on high pressure setting	X
Output per shot 'High Pressure' setting	0.45g	X
Output per shot 'High Volume' setting	1.25g	X
Output	60 shots per prime	54g per stroke
Bulk fillable	✓	X
Max grease type	NLGI No.2	NLGI No.2
Wetted Parts	Aluminium, steel, nitrile rubber	Aluminium, steel, brass, nitrile rubber and Teflon

Service Parts for K4-01

- **K4-1K:** Overhaul Kit

Service Parts for J3-01

- **J3-1K:** Seal Kit
- **J3-HOSE:** Extension hose

Application for K4-01

Suitable for use in all greasing applications

Application for J3-01

Bulk filling of reservoirs and most grease types available on the market

Recommended to be used with:



KYPLUS-01 Grease Coupler (Page 31)



ACK2-02 Aviation Greasing Kit (Page 34)



KDF13 Flexible Extensions 13" (Page 37)



KSR Button Head Coupler (Page 38)



KZDXL Needle Coupler (Page 36)

MANUAL GREASE PUMPS

K7 MINILUBE® Portable High Pressure Greasing System

The K7 MINILUBE® designed and manufactured for quality, reliability and performance. The MINILUBE® offers portable, powerful, professional greasing. The spring loaded pump feeds the KR PRESSURITE™ grease gun with enough grease pressure to deliver 30 shots of grease per prime, and will deliver pressures up to 10,000psi on the high pressure setting.

10
YEARS
MACNAUGHT
WARRANTY*

30 shots
of grease per
prime

KY SUPERGRIP™ Coupler
Positive leak free connection

360° ball swivel
Prevents hose kinking

Foot operated pump
Provides 30 shots per prime

Rubber edged follower plate
Prevents air pockets and contamination

KR PRESSURITE™ Gun
High pressure or high volume greasing

Fully sealed system
Prevents grease contamination

Fully repairable
Provides a longer service life

1.5m delivery hose
Easy to reach difficult applications

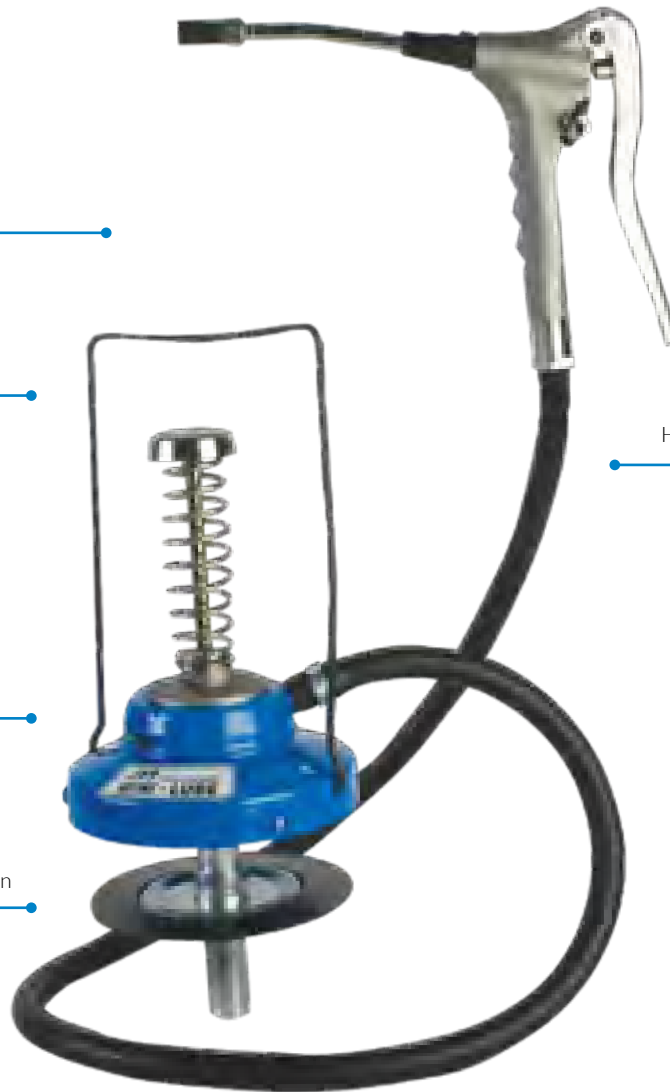

K7-01

Service Parts

- **K7-2K:** Top Assembly
- **K7-3K:** Seal Kit
- **KH40S:** Hose Assembly

Applications:

Suitable for use in all greasing applications

K7 MINILUBE® Greasing Systems



K7-01



K7-24



K7-67

Part Number	K7-01	K7-24	K7-67
Description	K7 MINILUBE® Portable Manual Greasing System	K7 MINILUBE® with 2.5Kg container	K7 MINILUBE® with 5Kg container
KR PRESSURITE™ dual pressure grease gun	✓	✓	✓
Fully serviceable	✓	✓	✓
Pail size	2.5Kg (5.5lb)	2.5Kg (5.5lb) container	5kg (11lb) container
Typical output pressure from KR PRESSURITE™ grease gun*	34, 450 – 68, 000kPa (5, 000 – 10, 000psi) on high pressure setting		
Output per shot 'High Pressure' setting	0.45g	0.45g	0.45g
Output per shot 'High Volume' setting	1.25g	1.25g	1.25g
Output shots per prime	30	30	30
Bulk fillable	✓	✓	✓
Max grease type	NLGI No.2	NLGI No.2	NLGI No.2
Wetted Parts	Aluminium, steel, nitrile rubber		

Recommended to be used with:



KYPLUS-01 Grease Coupler (Page 31)



KZD Needlepoint Coupler (Page 36)



KFR Rigid/Flexible extension (Page 37)



KZHY Hypodermic Needlepoint Coupler (Page 36)



KT5 / KT6 2.5kg/5kg grease containers (Page 38)

AIR OPERATED GREASE PUMPS

P58 MAXILUBE™ Heavy Duty Air Operated Grease Pump

The Macnaught P58 MAXILUBE™ (58:1) is a high pressure, high performance grease pump designed for use in the harshest of conditions. The heavy duty construction provides reliable on demand greasing over long greasing distances.

10
YEARS
MACNAUGHT
WARRANTY*

High Flow
Rate
up to
6kg/min

58:1 Ratio Air Motor

Heavy duty construction

Reliable long service life

High flow up to 6kg/min (free flow)

Fast high pressure greasing

High quality components

To ensure reliable operation in the harshest environments

Large silencer

Prevents icing and reduces noise

Quick grease line pressure recovery

Instant greasing

High pressure / high volume pump

Ideal for large workshops with long greasing distances

Fully Repairable

Spare parts availability

Heavy Duty Construction

Reliable long service life



P58-01

Service Parts

- P58-1K: Air Motor Overhaul Kit
- P58-3K: Seal Kit
- P58-2K: Lower Pump Service Kit

Applications:

For use in installations where long distance high pressure greasing is required

P58 MAXILUBE™ Grease Pumps

10
YEARS
MACNAUGHT
WARRANTY*

Accessories	
Lid & Follower Plate - 180Kg	P58LF-01
Pipe Adaptor Kit	TA-2K
Airline Oil Lubricator Kit	TA-3K
Air Filter and Regulator Kit	TA-7K
Grease hose - 2.5m	PF8
Grease hose - 4m (optional)	PF6
Booster Gun	B2-01
Graco to Macnaught adaptor	TJ061A
3" Camlock Adapter Kit	TJ062A



P58-01



P58PLF-01



P58PGLF-01

Part Number	P58-01	P58PLF-01	P58PGLF-01
Description	P58 Grease Pump - 180 KG	P58 Grease Pump Kit- with Lid and Follower - 180Kgs	P58 Grease Pump Kit - with Booster Gun, Lid and Follower - 180Kgs
Pressure Ratio	58:1	58:1	58:1
Air Pressure Operating Range	60 to 150psi	60 to 150psi	60 to 150psi
Air Consumption	23.5 SCFM (@120psi pressure, 20°C)	23.5 SCFM (@120psi pressure, 20°C)	23.5 SCFM (@120psi pressure, 20°C)
Max Fluid Outlet Pressure	8700psi (59, 900 kPa)	8700psi (59, 900 kPa)	8700psi (59, 900 kPa)
Air Motor Diameter	4.1" (104.7mm)	4.1" (104.7mm)	4.1" (104.7mm)
Max free Flow Delivery Rate	6 kg/min (13lb/min) (@120psi pressure, 20°C)	6 kg/min (13lb/min) (@120psi pressure, 20°C)	6 kg/min (13lb/min) (@120psi pressure, 20°C)
Air Inlet Size	1/4" BSPT	1/4" BSPT	1/4" BSPT
Fluid Outlet Size	3/8" BSPT	3/8" BSPT	3/8" BSPT
Wetted and Seal Materials	NBR	NBR	NBR
Noise Level	85 dB(A) (@120 psi)	85 dB(A) (@120 psi)	85 dB(A) (@120 psi)
Air Lubricator Included	Yes	Yes	Yes
Hose	X	X	2.5m x 6mm ID Delivery Hose
Control Gun	X	X	B2 Booster Gun with Z Swivel
Lid and Follower(180 kgs)	X	Lid and Follower - 180kgs (P58LF-01)	Lid and Follower - 180kgs (P58LF-01)
Grease up to	NLGI no 2	NLGI no 2	NLGI no 2
Pump Tube Diameter	41.3 mm O.D.	41.3 mm O.D.	41.3 mm O.D.
Pump tube height	960 mm	960 mm	960 mm
Total height	1396 mm	1396 mm	1396 mm
Weight	13 kgs	13 kgs	13 kgs

Recommended to be used with:



KYPLUS-01 Grease Coupler (Page 31)



PF17, PF9 Suitable Flexible Extensions (Page 37)



KZD Straight Needlepoint Coupler (Page 36)



KZDXL Straight Needlepoint Coupler (Page 36)



TA-7K Filter & Regulator Kit (Page 77)

AIR OPERATED GREASE PUMPS

POWERLUBE™ Air-operated Grease Pumps

The Macnaught POWERLUBE™ grease pump has been designed and manufactured for quality, reliability and performance. The POWERLUBE™ grease pump design provides a very efficient air motor with very low air consumption. The use of modern polymer materials means there is no need for any oil lubrication. Excellent for all high pressure, continuous greasing applications including underground coal mine applications. The POWERLUBE™ will give you many years of trouble free reliable service.

10
YEARS
MACNAUGHT
WARRANTY*

Low Air Consumption
(3 cfm)

No oil lubricator required

Quiet Air Motor Design

Meets all industry noise level standards.

Adjustable Collar System

To accommodate different height 20kg (or similar size) grease pails

Rubber-Edged Follower Plate

Prevents air pockets & contamination

Grease Strainer

Prevents grease contamination

4m High Pressure Grease Hose

Allows access to hard to reach applications



50:1 Ratio Air Motor

High Pressure output with up to 460g/m grease delivery

Low air consumption

Requires small air compressor

B2 Booster Gun

Boosts pressure up to 10,000psi to clear blocked grease nipples

KY SUPERGRIP™ Coupler

Positive no-leak connection

360° ZSB Swivel

Improves maneuverability and offers easier one-handed operation

Fully Repairable

Provides a much longer service life



P3-01C

Why choose this product?

Professional reliable solution for all greasing applications

Service Parts

- P3-1K: Air Motor Seal Kit
- P3-5K: Pump Seal Kit
- P3-3K: Seal Kit
- PA30S: Valve Body Complete

Applications:

Suitable for use in all greasing applications

POWERLUBE™ Air-operated Grease Pumps

10
YEARS
MACNAUGHT
WARRANTY*



P3-01C
(15-20Kg)



P6-01
(55kg)



P8-11
(180kg)

Part Number	P3-01C	P6-01	P8-11
Description	POWERLUBE™ 15-20KG Grease Kit	POWERLUBE™ 55KG Grease Kit	POWERLUBE™ 180KG Grease Kit
Pump only part number	P3001	P6001	P8001
Pump ratio	50:1 Ratio	50:1 Ratio	50:1 Ratio
Max pump output pressure	51,700kPa (7,500psi)	51,700kPa (7,500psi)	51,700kPa (7,500psi)
Max gun output pressure	68,900 kPa (10,000psi)	68,900 kPa (10,000psi)	68,900 kPa (10,000psi)
Suited to pails	15 - 20Kg(33lb-44lb)	55kg (120lb)	180kg (400lb)
Hose	4m (13ft) x 6mm (1/4") ID delivery hose	4m (13ft) x 6mm (1/4") ID delivery hose	2.5 (8ft) x 6mm (1/4") ID delivery hose
Control gun	B2 Booster Gun comes with ZSB swivel	B2 Booster Gun comes with ZSB swivel	B2 Booster Gun comes with ZSB swivel
Output	460g/min (1lb/min)	460g/min (1lb/min)	460g/min (1lb/min)
Air Motor Diameter	70mm (2 3/4")	70mm (2 3/4")	70mm (2 3/4")
Suction Tube Length	465mm (18")	596mm (23.5")	885mm (35")
Suction Tube Diameter	28.5mm (1 1/8")	28.5mm (1 1/8")	28.5mm (1 1/8")
Total Height	650mm (25")	780mm (30")	1065mm (42")
Total Weight	9Kg (20lb) / (4Kg (9lb) Pump only)	10Kg (22lb) / (4.5Kg (10lb) Pump only)	10Kg (43lb) / (5.5Kg (12lb) Pump only)
Noise Level	85dB @ 2m	85dB @ 2m	85dB @ 2m
Grease viscosity	Up to NLGI No.2	Up to NLGI No.2	Up to NLGI No.2
Wetted components	Zinc, Hard Chrome-Plated Carbon Steel, Brass, Nitrile and Polyurethane rubber		
Air Pressure range	60 - 150psi (413kPa - 1034kPa)	60 - 150psi (413kPa - 1034kPa)	60 - 150psi (413kPa - 1034kPa)
Air inlet	1/4" NPT (F)	1/4" NPT (F)	1/4" NPT (F)
Pump outlet	1/4" NPT (F)	1/4" NPT (F)	1/4" NPT (F)
Min compressor size	0.08m³/min (3 cfm)	0.08m³/min (3cfm)	0.08m³/min (3cfm)

Recommended to be used with:



KYPLUS-01
Grease Coupler
(Page 31)



TR5-01
20kg Trolley
(Page 39)



KZDXL
Straight Needlepoint
Coupler (Page 36)



TR20G
20kg Trolley
(Page 39)



TA-7K
Filter & Regulator Kit
(Page 77)

AIR OPERATED GREASE PUMP KITS

POWERLUBE™ Grease Kits with Trolley

The POWERLUBE™ grease pump kits are available with a robust suitable TR20G (20Kg) trolley to provide greater mobility and easy maneuverability around the workshop.

10
YEARS
MACNAUGHT
WARRANTY*

Rubber-Edged Follower Plate

Prevents air pockets & contamination

KY SUPERGRIP™ Coupler

Positive leak free connection

B2 Booster Gun

Boosts grease pressure up to 10,000 psi when required

4m high pressure grease hose

Extra hose length for easier access to difficult applications

POWERLUBE P3-01C Grease Pump Kit

50:1 Grease Pump Kit suitable for 20 kgs drums

Non-corroding air motor design

No airline lubricator required

TR20G 20Kg Trolley

Drum trolley to suit 20 kg grease drums with large and wide base plate which offers a stable platform



P3-01CTROLLEY
(15-20Kg)



Why choose this product?

Portable solution for all greasing applications

Service Parts

- P3-1K: Air Motor Seal Kit
- P3-5K: Pump Seal Kit
- P3-3K: Seal Kit
- PA30S: Valve Body Complete

Applications:

Suitable for use in all greasing applications

POWERLUBE™ Grease Kits with Trolley

10
YEARS
MACNAUGHT
WARRANTY*



P3-01CTROLLEY
(15-20kg)



P6-01TROLLEY
(55kg)



P8-11TROLLEY
(180kg)

Part Number	P3-01CTROLLEY	P6-01TROLLEY	P8-11TROLLEY
Description	POWERLUBE™ P3 Grease Kit with Trolley	POWERLUBE™ P6 Grease Kit with Trolley	POWERLUBE™ P8 Grease Kit with Trolley
Pump only part number	P3001	P6001	P8001
Pump ratio	50:1 Ratio	50:1 Ratio	50:1 Ratio
Max pump output pressure	51,700kPa (7,500psi)	51,700kPa (7,500psi)	51,700kPa (7,500psi)
Max gun output pressure	68,900 kPa (10,000psi)	68,900 kPa (10,000psi)	68,900 kPa (10,000psi)
Suited to pails	15 - 20kg (33lb-44lb)	55kg (120lb)	180kg (400lb)
Hose	4m (13ft) x 6mm (1/4") ID delivery hose	4m (13ft) x 6mm (1/4") ID delivery hose	2.5m (8ft) x 6mm (1/4") ID delivery hose
Control gun	B2 Booster Gun comes with ZSB swivel	B2 Booster Gun comes with ZSB swivel	B2 Booster Gun comes with ZSB swivel
Trolley	TR20G	TR20G	TR205 - 180kg Trolley
Output	460g/min (1lb/min)	460g/min (1lb/min)	460g/min (1lb/min)
Air Motor Diameter	70mm (2 3/4")	70mm (2 3/4")	70mm (2 3/4")
Suction Tube Length	465mm (18")	596mm (23.5")	885mm (35")
Suction Tube Diameter	28.5mm (1 1/8")	28.5mm (1 1/8")	28.5mm (1 1/8")
Total Height	650mm (25")	780mm (30")	1065mm (42")
Total Weight	9Kg (20lb) / (4Kg (9lb) Pump only)	10Kg (22lb) / (4.5Kg (10lb) Pump only)	10kg (43lb) / (5.5kg (12lb) Pump only)
Noise Level	85dB @ 2m	85dB @ 2m	85dB @ 2m
Grease viscosity	Up to NLGI No.2	Up to NLGI No.2	Up to NLGI No.2
Wetted components	Zinc, Hard Chrome-Plated Carbon Steel, Brass, Nitrile and Polyurethane rubber	Zinc, Hard Chrome-Plated Carbon Steel, Brass, Nitrile and Polyurethane rubber	Zinc, Hard Chrome-Plated Carbon Steel, Brass, Nitrile and Polyurethane rubber
Air Pressure range	60 - 150psi (413kPa - 1034kPa)	60 - 150psi (413kPa - 1034kPa)	60 - 150psi (413kPa - 1034kPa)
Air inlet	1/4" NPT (F)	1/4" NPT (F)	1/4" NPT (F)
Pump outlet	1/4" NPT (F)	1/4" NPT (F)	1/4" NPT (F)

Recommended to be used with:



KYPLUS-01
Grease Coupler
(Page 31)



KZDXL
Straight Needlepoint
Coupler (Page 36)



PF17, PF30 - Suitable
Flexible Extensions
(Page 37)



TA-7K
Filter & Regulator Kit
(Page 77)



TR5-01
Drum trolley
(Page 39)

AIR OPERATED GREASE SYSTEMS

POWERLUBE™ Portable Greasing System

The POWERLUBE Portable Greasing System uses the powerful 50:1 air-operated grease pump. The P3-OS2 is excellent for mobile applications where users require continuous high pressure greasing. This portable grease dispensing system is equipped with a low air consumption motor that doesn't need to be lubricated due to the use of modern polymer materials.

10
YEARS
MACNAUGHT
WARRANTY*

POWERLUBE™ Stationary Grease System

The SGS100 POWERLUBE Stationary grease dispensing system to suit 180kg (400lb) grease drums. The system includes GR215K grease reel and a P8 (50:1) ratio air operated grease pump. Complete with all fittings and hoses. The system is designed to suit most of your remote or workshop greasing requirements.

POWERLUBE™ 50:1 grease pump

Oil free air motor, robust construction for performance and reliability

B2 Booster Gun with KY SUPERGRIP™ Coupler

Positive no-leak connection. Boosts up to 10,000psi at B2-01 gun

Quality sealed container and trolley system

Prevents grease contamination



Retracta R3 Premium Grease Reel
Premium quality hose reel 1/4" x 15m high pressure grease hose

Part Number	P3-OS2	SGS100-01
Description	POWERLUBE™ Portable Greasing System	POWERLUBE™ Stationary Grease System - 180kg
Bare pump	P6001	P8001
Pump ratio	50:1 Ratio	50:1 ratio
Max pump output pressure	51,700kPa (7,500psi)	51,700kPa (7,500psi)
Max gun output pressure	68,900 kPa (10,000psi)	68,900 kPa (10,000psi)
Suited to pails	12.5 – 25kg (28lb - 55lb)	180kg (400lb)
Hose	4m (13ft) x 6mm (1/4") ID delivery hose	Retracta - GR215K-01 - 15m (50ft) x 6mm (1/4")
Control gun	B2 Booster Gun comes with ZSB swivel	B2 Booster Gun comes with ZSB swivel
Output	460g/min (1lb/min)	460g/min (1lb/min)
Grease viscosity	Up to NLGI No.2	Up to NLGI No.2
Air Pressure range	60 - 150psi (413kPa - 1034kPa)	60 - 150psi (413kPa - 1034kPa)
Air Motor Diameter	70mm (2 3/4")	
Suction Tube Length	596mm (23.5")	
Suction Tube Diameter	28.5mm (1 1/8")	
Total Height	780mm (30")	
Total Weight	10Kg (22lb) / (4.5Kg (10lb) - pump only)	
Noise Level	85dB @ 2m	
Wetted components	Zinc, Hard Chrome-Plated Carbon Steel, Brass, Nitrile and Polyurethane rubber	
Air inlet	1/4" NPT (F)	
Pump outlet	1/4" NPT (F)	
Min compressor size	0.08m ³ /min (3 cfm)	

Service Parts

- P3-1K: Air Motor Seal Kit
- P3-3K: Seal Kit
- P3-5K: Pump Seal Kit
- PA30s: Valve Body Complete

Applications:
Suitable for all workshop greasing applications

Recommended to be used with:



KYPLUS-01
Grease Coupler
(Page 31)



PF17, PF9
Suitable Flexible
Extensions (Page 37)



KZDXL
Straight Needlepoint
Coupler (Page 36)



TA-7K
Filter & Regulator Kit
(Page 77)

GS100 POWERLUBE™ Portable Trolley Grease System

The GS100 POWERLUBE™ Portable trolley based grease dispensing system to suit 180kg (400lb) grease drums. The system includes TR205 trolley, GR215K grease reel and a P8 (50:1) ratio air operated grease pump. Complete with all fittings and hoses.



POWERLUBE™ 50:1 grease pump
High pressure greasing with flow rates up to 460g/min

Heavy Duty Steel Drum Lid
Solid support for the for the pump and protects grease from contamination

Chain drum retainer
Secure drum retention during maneuvering

Heavy Duty TR205 Trolley
Stable platform with large wheels for ease of maneuver



Retracta R3 Premium Grease Reel
Premium quality hose reel with 15m of 1/4" high pressure grease hose

B2 Booster Gun with KY SUPERGRIP™ Coupler
Positive no-leak connection. Boosts up to 10,000psi at B2-01 booster gun

Wheel Lock
For safe and steady operation of the system

*180kg drum not included

Part Number	GS100-01
Description	Portable Trolley Based Greasing System
Feature	Complete greasing system
Pump ratio	50:1 Ratio
Max pump output pressure	51,700kPa (7,500psi)
Max gun output pressure	68,900 kPa (10,000psi)
Bare pump	P8001 - POWERLUBE™
Suited to pails	180kg (400lb)
Hose	GR215K grease reel -15m (50ft) x 6mm (1/4")
Control gun	B2 Booster Gun with ZSB swivel
Trolley	TR205-01
Output	460g/min (1lb/min)
Airline lubricator	Not required
Warranty ¹	10 years
Grease viscosity	Up to NLGI No.2
Max air pressure	150psi (1,034kPa)
Min air pressure	60psi (413kPa)

Why choose this product?

Portable solution for all greasing applications

Service Parts

- **P3-1K:** Air Motor Seal Kit
- **P3-3K:** Seal Kit
- **P3-5K:** Pump Seal Kit
- **PA30s:** Valve Body Complete

Applications:

Suitable for all greasing applications where portable greasing is required

Recommended to be used with:



KYPLUS-01
Grease Coupler
(Page 31)



PF17, PF9
Suitable Flexible
Extensions (Page 37)



KZD
Straight Needlepoint
Coupler (Page 36)



KZDXL
Straight Needlepoint
Coupler (Page 36)



TA-7K
Filter & Regulator Kit
(Page 77)

GREASE ACCESSORIES

KY+ Safety Grease Coupler

The innovative new KY+ grease coupler is a game changer in equipment maintenance. In fact, for any high grease application, KY+ delivers improved access, productivity and safety through a new patented design. The “superior interior” is the KY+ difference. KY+ is more versatile, reliable, leak free and easy to use. Macnaught has again lifted the standard for grease couplers.



Internal Pressure Relief
For greater safety and minimise grease spurts.

Quick & easy release mechanism

Patent approved smart release mechanism enables effortless one handed release & pull up to 10,000psi.

Original KY floating jaw

Unique floating jaw operation creates a powerful grip as pressure builds to enhance performance.



KYPLUS-01

Superior safety

Smart release mechanism features an internal bleeding system for soft pressure relief and safe disconnect of the coupler up to 10,000 psi.

Compact design

The compact body of the KY+ makes it easier to get into tight spaces.

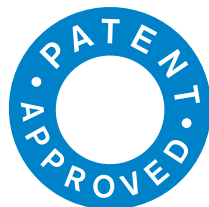

GOOD DESIGN AWARD® WINNER

Service Parts

- KYPLUS-1K: Overhaul Kit

Applications:

Automotive, Truck and Buses, Farming Equipment, Textile Machinery, Construction and Earthmoving, Forklifts, Military Equipment (e.g. Tanks, armoured vehicles), Mining Machinery, Aircraft, Trains

(Australian Patent No. 2018256611. International Patent Application No. PCT/AU2018/050651)

KY+ Safety Grease Coupler Range



Blister Packaging



KYPLUS-01 (1/8" BSP)

KYPLUS-02 (1/8" NPT)

KYPLUS-03 (M10X1)

Counter Display

- KYPLUS-01-10 (BSP)
- KYPLUS-02-10 (NPT)
- KYPLUS-03-10 (M10X1)



KY+ 10 Trade Pack

- KYPLUS-01TP (BSP)
- KYPLUS-02TP (NPT)



KY+ 100 Trade Pack

- KYPLUS-01TP-100 (BSP)
- KYPLUS-02TP-100 (NPT)



Part Number	Description	Thread Type	Max Working Pressure:	Coupler Quantities
KYPLUS-01	KYPLUS Grease Coupler - BSP	1/8" BSP	10,000psi (68,900kPa)	1
KYPLUS-02	KYPLUS Grease Coupler - NPT	1/8" NPT		
KYPLUS-03	KYPLUS Grease Coupler - M10X1	M10X1 (F)		
KYPLUS-01-10	KYPLUS Grease Coupler - BSP (Counter Display - 10's pack)	1/8" BSP		10 (in blister packs)
KYPLUS-02-10	KYPLUS Grease Coupler - NPT (Counter Display - 10's pack)	1/8" NPT		
KYPLUS-03-10	KYPLUS Grease Coupler - M10X1 (Counter Display - 10's pack)	M10X1 (F)		
KYPLUS-01TP	KYPLUS Grease Coupler - BSP (Trade Pack - 10 Units)	1/8" BSP		10 (bare units)
KYPLUS-02TP	KYPLUS Grease Coupler - NPT (Trade Pack - 10 Units)	1/8" NPT		
KYPLUS-01TP-100	KYPLUS Grease Coupler - BSP (Trade Pack - 100 Units)	1/8" BSP		
KYPLUS-02TP-100	KYPLUS Grease Coupler - NPT (Trade Pack - 100 Units)	1/8" NPT	100	

Recommended to be used with:

All grease guns and grease pumps

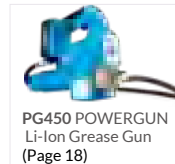

GREASE ACCESSORIES

KY+XL Safety Grease Coupler

The innovative new KY+XL grease coupler is a game changer in equipment maintenance. In fact, for any high grease application, KY+XL delivers improved access, productivity and safety through a new patented design. The "superior interior" is the KY+XL difference. KY+XL is more versatile, reliable, leak free and easy to use. The KY+XL nose is 2.5" (64mm) longer than the KY+.

2
YEARS
MACNAUGHT
WARRANTY*

KY+
LOAD & LUBE
SAFETY GREASE COUPLER
XL

Internal Pressure Relief

For greater safety and minimise grease spurts.

Quick & easy release mechanism

Patent approved smart release mechanism enables effortless one handed release & pull up to 10,000psi.

Original KY floating jaw

Unique floating jaw operation creates a powerful grip as pressure builds to enhance performance.



KYPLUSXL-01

Superior safety

Smart release mechanism features an internal bleeding system for soft pressure relief and safe disconnect of the coupler up to 10,000 psi.

Compact design

The compact body of the KY+ makes it easier to get into tight spaces.

Up to
10,000
psi

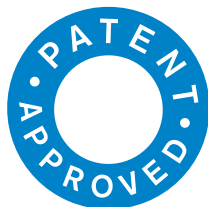

**GOOD
DESIGN
AWARD®
WINNER**

Service Parts

- KYPLUS-1K: Overhaul Kit

Applications:

Automotive, Truck and Buses, Farming Equipment, Textile Machinery, Construction and Earthmoving, Forklifts, Military Equipment (e.g. Tanks, armoured vehicles), Mining Machinery, Aircraft, Trains

KY+XL Safety Grease Coupler Range



Blister Packaging



KYPLUSXL-01 (1/8" BSP)



KYPLUSXL-02 (1/8" NPT)



KYPLUSXL-03 (M10X1)

Counter Display

- KYPLUSXL-01-10 (BSP)
- KYPLUSXL-02-10 (NPT)
- KYPLUSXL-03-10 (M10X1)



Part Number	Description	Thread Type	Max Working Pressure:	Coupler Quantities
KYPLUSXL-01	KYPLUSXL Grease Coupler - BSP	1/8" BSP	10,000psi (68,900kPa)	1
KYPLUSXL-02	KYPLUSXL Grease Coupler - NPT	1/8" NPT		
KYPLUSXL-03	KYPLUSXL Grease Coupler - M10X1	M10X1 (F)		
KYPLUSXL-01-10	KYPLUSXL Grease Coupler - BSP (Counter Display - 10's pack)	1/8" BSP		10 (in blister packs)
KYPLUSXL-02-10	KYPLUSXL Grease Coupler - NPT (Counter Display - 10's pack)	1/8" NPT		
KYPLUSXL-03-10	KYPLUSXL Grease Coupler - M10X1 (Counter Display - 10's pack)	M10X1 (F)		

Recommended to be used with:

All grease guns and grease pumps

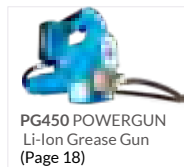

GREASE ACCESSORIES

ACK2 Greasing Accessories Kit

The ACK2 Greasing Accessories kit (the Aviation Kit) is a comprehensive range of greasing couplers required for the maintenance of aircraft and associated equipment. This kit has been developed in consultation with the aviation industry to fill their specific requirements. The ACK2 greasing kit would also suit any industry that has varied greasing applications requirements, specifically for hard to reach and access grease nipples.



ACK2-02

Package Includes

- 1. KDN - Quick Connect 90 Degree Angle Coupler
- 2. KZHY - Long Hypodermic Needle Point Coupler
- 3. KZSNR - Short 90 Degree Angle Coupler
- 4. KZLN45 - 300mm X 45 DEG Long Needle Point Coupler
- 5. KZLNR - 300mm 90 DEG Long Needle Point Coupler
- 6. KY - SUPERGRIP™ Coupler
- 7. KZDXL - Long Straight Needle Point Coupler
- 8. KDE8 - Quick Connect Rigid Extension - 200MM
- 9. KDR - Quick Connect 90 Degree Angle Coupler
- 10. KDF21 - Quick Connect Flexible Extension - 530MM
- 11. KZLNS - 300mm Long Needle Point Coupler
- 12. KZLNJ - 300mm X "J" Long Needle Point Coupler
- 13. J65 - Adaptor Assembly

Features & Benefits

- ACK2 is the complete coupler kit
- Includes a blow moulded carry case
- Various length & angle needle point couplers
- 2 x short 90° couplers (needle point & standard)
- Long hypodermic needle
- Long clip on 21"(530mm) flexible extension

Applications:

Suitable for all industries where greasing is required

Recommended to be used with:



K29-01
FLEXIGUN®
450g (Page 15)



K32-01
FLEXIGUN®
400g (Page 15)



K45-01
LEVERGUN®
450g (Page 16)



K40-01
LEVERGUN®
400g (Page 16)



PG450
POWERGUN™ 18V
Grease Gun (Page 18)

Refillable Single Point Grease Lubricators



Designed to provide consistent lubrication in hard to reach, hidden, or easy to forget greasing points on fixed plant machinery, conveyor systems, process machinery, block bearings, bushings and joints. The MCGL100 and the MCGL220 lubricators are suitable for greases up to NLGI no2 viscosity, have a flow adjustment screw and are supplied with two different strength springs to select according to grease viscosity. The lubricators can be easily filled through the grease nipple located on the side of the lubricators. These continuous bearing lubricators made from UV stable, impact resistant Lexen® can be mounted in any orientation and provides refillable longevity in temperatures from -10°C to 80°C.

Strong Transparent Lexen®
Easy to see grease level

100ml Capacity
For greases up to NLGI No.2

Flow Adjustment Screw



MCGL100-01 (100ml)

MCGL220-01 (220ml)

Supplied with 2 Springs

Heavy gauge spring - strong tension
Lighter gauge spring - medium tension

Grease Nipple (Filling Point)

Easy filling using standard grease gun

1/8" BSP Adaptor

Fitted at the bottom of the M10X1 thread

Part Number	MCGL100-01	MCGL220-01
Description	Single Point Grease Lubricator - 100ml	Single Point Grease Lubricator - 220ml
Capacity	100ml	220ml
Temperature Range	-10°C to 80°C	-10°C to 80°C
Outlet Thread	1/8" BSP adaptor	1/8" BSP adaptor

Applications:

Hidden or hard to access greasing points, fixed plant machinery, conveyor systems, process machinery, block bearings, bushings and joints.

Recommended to be used with:



GREASE ACCESSORIES



NEEDLEPOINT COUPLER HYPODERMIC KZHY

Push-on hypodermic grease coupler – 130mm (5.125"). Temporary coupler for use with bearings which have rubber dust covers where the standard KIN coupler won't reach



NEEDLEPOINT COUPLER – 90° KZSNR

Push-on needlepoint grease extension – 110mm (4.25") with 90° angle at end to access different grease points



LONG STRAIGHT NEEDLEPOINT COUPLER KZDXL

Ideal for greasing the bearings on four wheel drive vehicles. Length 120 mm (4 3/4").



NEEDLEPOINT COUPLER – 45° KZLN45

Push-on needlepoint grease extension – 300mm (12") with 45° angle at end



NEEDLEPOINT COUPLER 90° (12") KZLNR

Push-on needlepoint grease extension – 300mm (12") with 90° angle at end



NEEDLEPOINT COUPLER – 12" KZLNS

Push-on needlepoint grease extension – 300mm (12")



NEEDLEPOINT COUPLER J BEND KZLNJ

Push-on needlepoint grease extension – 300mm (12") with J bend at end



NEEDLENOSE COUPLER KZD

Used when nipples are recessed and standard couplers would meet with interference from surrounding components (universal joints, etc). Length 93 mm (3 3/4")



CONCAVE NIPPLE COUPLER KZE

Push-on concave grease coupler – 60mm (2.25"). Temporary connector where special or damaged type nipples are encountered

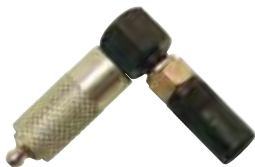

RIGHT ANGLE COUPLER KDR

Push-on right-angle coupler – Standard temporary attachment for greasing in tight areas where access by a standard coupler isn't available



NEEDLEPOINT COUPLER RIGHT ANGLE KDN

Push-on right-angle needlepoint extension. used for temporary attachment to grease in difficult applications where using a normal coupler is impossible to use



FLEXIBLE EXTENSION – 21" KDF21

Push-on flexible grease extension – 530mm (21"). Can be used to temporarily extend existing rigid or flexible extensions



RIGID EXTENSION - 8"

KDE8

Push-on rigid grease extension - 200mm (8"). Useful to temporarily extend reach capacity on existing rigid or flexible extensions fitted



FLEXIBLE EXTENSION - 13"

KDF13

Push-on flexible grease extension - 330mm (13"). Can be used to temporarily extend existing rigid or flexible extensions



GREASE INJECTOR NEEDLE

KIN

Push-on grease injector needle. Used to dispense grease into sealed bearings and steering components if normal nipples aren't available



FLEXIBLE EXTENSION - 12"

KF9

Flexible grease extension - 300mm (12"). Suitable for both hand or powered greasing equipment; 1/8" BSP (M) fittings on both ends



FLEXIBLE EXTENSION - 17"

KF17

Flexible grease extension - 430mm (17"). Suitable for both hand or powered greasing equipment; 1/8" BSP (M) fittings on both ends



FLEXIBLE EXTENSION - 17"

PF17

430mm (17") flexible extension. Suitable for powered greasing equipment. 1/8" BSP (M) on both ends. Suited for B2-01 Booster Gun as includes B2-01 adaptor.



HIGH PRESSURE DELIVERY HOSE - 30"

PF30

760mm (30") high pressure grease delivery hose. 1/4" NPT (M) on both ends. Includes B2-01 adaptor.



RIGID/FLEXIBLE EXTENSION - 13"

KFR

Flexible/rigid grease extension - 330mm (13"). Useful tool to allow the operator both flexible or rigid extensions by simply moving the sleeve forward or back



HIGH PRESSURE FLEXIBLE EXTENSION - 12"

PF9

300mm (12") high pressure flexible extension suitable for use with air operated greasing equipment, 1/8" BSP (M) on both ends. Suited for B2-01 Booster Gun as includes B2-01 adaptor.



EXTENSION HOSE - 4m x 6mm

PF6

4m (13ft) x 6mm (1/4") i.d. high pressure grease delivery hose. 1/4" NPT (M) on both ends

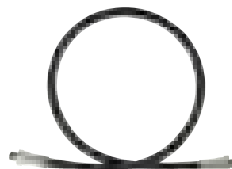

EXTENSION HOSE - 2.5m x 6mm

PF8

2.5m (8ft) x 6mm (1/4") i.d. high pressure grease delivery hose. 1/4" NPT (M) on both ends



FLEXIBLE EXTENSION - 30"

KF30

Flexible grease extension - 760mm (30"). Suitable for both hand or powered greasing equipment

GREASE ACCESSORIES



PRESSURE RELIEF VALVE PRV-25

- Prevents damage caused by excess greasing pressure
- Relieving pressure set at 2,500psi (17,237kPa)
- Can be fitted to most manual, air & battery grease guns



GREASE FITTING UNBLOCKER GFU

Opens clogged grease fittings and loosens hardened grease joints. Excellent for maintaining and protecting bearings, control arms, joints, king pins, etc. Comes complete with grease coupler for connection onto the grease fitting and 2 spare seals for replacing the piston seals as they wear.

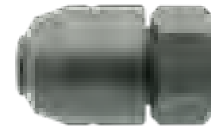

BULK FILL ADAPTOR ASSEMBLY

J65

Filler adaptor assembly for the J3 grease transfer pump. Allows connection to the filler/bleeder valve to refill cartridge guns from bulk grease pails.



KR PRESSURITE™ KR

Grease gun only suited to use with K3/K4 and K6/K7 hand-operated pumps. Offers both high volume or high-pressure greasing.

Service Parts

- **KR-1K:** Overhaul Kit



BOOSTER GUN WITH SAFETY GUARD

B2-SG

Booster gun with safety guard. Fitted with trigger hand guard to protect the operator.

Service Parts

- **B2-1K:** Service Kit for B2/B3 Guns



360° SWIVEL

ZSB

"Z" Type high pressure grease swivel. Used to overcome difficulty by operator to grease hard to reach lube points 1/8" NPT (M) x 1/4" NPT (F).



STANDARD BUTTONHEAD COUPLER

KSR

Push-on standard button head grease coupler - 5/8". Easy connect/disconnect coupler to allow greasing of the smaller buttonhead type fittings.



GIANT BUTTONHEAD COUPLER

KGR

Push-on giant button head grease coupler - 7/8". Easy connect/disconnect coupler to allow greasing of the larger buttonhead type fittings.



SNAP ON ADAPTOR

KDA

Snap on adaptor with 1/8" BSP (F) threaded outlet.



CONCAVE NIPPLE COUPLER KZX

Push-on concave grease coupler - 200mm (8"). Temporary connector where special or damaged type nipples are encountered.



GREASE CONTAINER - 2.5KG KT5

2.5Kg (5.5lb) Reusable grease container to suit K7-01.

GREASE CONTAINER - 5KG KT6

5Kg (11lb) Reusable grease container to suit K7-67.



FLEXILUBE GREASE FB2-450

450g (16oz) grease cartridge - carton of 12 water resistant lithium complex type lubricant (NLG12) - multipurpose grease for high temperature applications.



COUPLER

KY (1/8" BSP)

Standard SUPERGRIP™ coupler supplied with all Macnaught grease guns. Designed to fit most grease nipples and grease guns.

Additional Options

- KY2P** 1/8" (F) BSP Coupler pack of 2
- KY-10** 1/8" (F) BSP Coupler pack of 10
- KY-50** 1/8" (F) BSP Coupler pack of 50
- KY-N** 1/8" (F) NPT Coupler
- KY-M** M10X1 (F) Coupler

Service Parts

- **KY3S:** Pack of 8 SUPERGRIP™ Grease Coupler Seals



10
YEARS
MACNAUGHT
WARRANTY*

BOOSTER GUN

B2-01 (with swivel)

- Delivery pressure up to 689bar/68,950Pa (10,000psi)
- Used for high pressure delivery with any air-powered grease pump
- Increases the inlet grease pressure to overcome line resistance or nipple blockages
- 1/4" NPT(F) inlet

Additional Options

- B2** - Booster Gun without Swivel

Service Parts

- **B2-1K:** Service Kit for B2/B3 Guns



DRUM TROLLEY - 20KG

TR5-01

Drum trolley for 20kg (44lb) grease drums

DRUM TROLLEY - 55KG

TR6-01

Drum trolley for 55kg (120lb) grease drums



400G BARREL CONVERSION KIT

KF300-1K

400G barrel with adaptor suits all Macnaught 450g grease guns



NON-BOOSTER GUN

B3-01 - Non-Booster Gun with Swivel

B3 - Non-Booster Gun without swivel

- Delivery pressure up to 689bar/68,950Pa (10,000psi)
- Used for high pressure delivery with any air-powered grease pump
- Increases the inlet grease pressure to overcome line resistance or nipple blockages
- 1/4" NPT(F) inlet



DRUM TROLLEY - 20KG

TR20G

Multi-purpose drum trolley to suit both 20Kg (44lb) and 55kg (120lb) grease drums



DRUM TROLLEY - 180KG

TR205-01

Heavy duty trolley designed to suit drums up to 180kg (400lb). Large main wheels with a steerable braked third wheel. Very low loading height.



DRUM COVER AND FOLLOWER PLATE FOR P8 POWERLUBE™

P8LF-01

Tough powder coated steel drum cover, rubber edged follower plate with handle and release valve. Fits 180kg/ 400lb grease drums

12
MONTH
MACNAUGHT
WARRANTY*

BATTERY OPERATED PUMPS

BOP20 BATTERY OPERATED PUMP

Simple yet clever, the BOP is a portable, rechargeable, 18 volt battery operated oil pump, designed to improve workshop efficiency & reduce workshop fatigue inherent with operating manual oil pumps.



Easy portable Powerhead

Single Powerhead for multiple pump stems

Lithium-ion Battery and Charger

18V rechargeable 2.0Ah battery delivers up to 105L per charge

Drain back Adaptor

To drain back oil residue back to the drum

New modular concept

Sealed wetted parts for zero contamination

Adjustable suction tube



BP20S-OLA

Easy control nozzle

Simple single handed 'on demand' flow nozzle

½" x 1.5m hose (for all models except HV) and
¾" x 1.5m Transparent hose (HV models only)



BOP20 Starter Kit

Pump stem, Powerhead, hose & gun assembly, battery pack and charger.

BOP20 Pump Stem Kits

Pump stem, hose & gun assembly.

Service Parts

- BP-1K: Seal kit for Std BOP
- BP-2K: Seal Kit for HV and ATF
- BP-3K: Seal Kit for Coolant
- BP-HG: Gun and Hose Set
- BP20-AK: Bung Adaptor Kit suitable for BOP20 pump stems
- BP-HGHV: High Vis Gun and Hose Set
- BP077S: Nozzle dust cap

Applications:

Suitable for use in all industries to replace old style manual operated drum pumps

Part Number	BP20S-OLA	BP20S-OHA
Description	BOP20 Starter kit	High Viscosity BOP20 Starter Kit
Delivery rate*	Up to 3.5L/min**	Min 2L/min**
Oil Drum size	20L	20L
Hook colour	Black	Yellow
On demand flow control	✓	✓
Easy flow control nozzle	✓	✓
Portable Powerhead	✓	✓
Self-Priming	✓	✓
Safety lockout carry handle	✓	✓
Sealed Wetted parts	✓	✓
Compatible fluids	Suitable for Oils up to SAE75W90	Suitable for Heavy Oils up to SAE140
Rechargeable Battery	2.0Ah Li-Ion	2.0Ah Li-Ion
Charger	1hr fast	1hr fast

BOP20

BATTERY OPERATED PUMP

For 20 Litre Drums

2
YEARS
MACNAUGHT
WARRANTY*

BP20X-OLA
Pump Stem suitable
for oils up to
SAE75W90



LOW-MID
VISCOSITY
OILS

BP20X-OHA
Pump Stem suitable
for heavy oils up to
SAE140



MID-HIGH
VISCOSITY
OILS

BP20X-ALA
Pump Stem suitable
for ATF



ATF
COMPATIBLE

BP20X-COA
Pump Stem suitable
for coolant



COOLANT
COMPATIBLE

Part Number	BP20X-OLA	BP20X-OHA	BP20X-ALA	BP20X-COA
Description	BOP20 Pump Stem Kit	High Viscosity Pump Stem Kit	ATF Pump Stem Kit	Coolant Pump Stem Kit
Delivery rate*	Up to 3.5L/min**	Min 2L/min**	Up to 4.5L/min	Up to 5.8L/min
Oil Drum size	20L	20L	20L	20L
Hook colour	Black	Yellow	Red	Green
On demand flow control	✓	✓	✓	✓
Easy flow control nozzle	✓	✓	✓	✓
Portable Powerhead	✗	✗	✗	✗
Self-Priming	✓	✓	✓	✓
Safety lockout carry handle	✓	✓	✓	✓
Sealed Wetted parts	✓	✓	✓	✓
Compatible fluids	Suitable for Oils up to SAE75W90	Suitable for Heavy Oils up to SAE140	ATF	Coolant
Rechargeable Battery	✗	✗	✗	✗
Charger	✗	✗	✗	✗

* The delivery rates depend on the type, viscosity the temperature of the fluid.
**SAE40 at 20°C (OLA models) , SAE140 at 20°C (OHA models)

Recommended to be
used with:



BP20-PH
Powerhead
To suit pump
stems.
Battery NOT
included.



BPB-20AH
18VDC-2.0AH
Li-Ion battery



BPC-A
BOP Charger
suited for 2.0AH
Battery (Available
for other countries
- USA, UK, Europe)

BATTERY OPERATED PUMPS

BOP60 BATTERY OPERATED PUMP

Simple yet clever, the BOP is a portable, rechargeable, 18 volt battery operated oil pump, designed to improve workshop efficiency & reduce workshop fatigue inherent with operating manual oil pumps.



Easy portable Powerhead

Single Powerhead for multiple pump stems

Lithium-ion Battery and Charger

18V rechargeable 2.0Ah battery delivers up to 105L per charge

Drain back Adaptor

To drain back oil residue back to the drum

New modular concept

Sealed wetted parts for zero contamination

Adjustable suction tube



BP60S-OLA

Easy control nozzle

Simple single handed 'on demand' flow nozzle

½" x 1.5m hose (for all models except HV) and ¾" x 1.5m Transparent hose (HV models only)

BOP60 Starter Kit

Pump stem, powerhead, hose & gun assembly, battery pack and charger.

BOP60 Pump Stem Kits

Pump stem, hose & gun assembly.

Service Parts

- BP-1K: Seal kit for Std BOP
- BP-2K: Seal Kit for HV and ATF
- BP-3K: Seal Kit for Coolant
- BP20-1K: Pump Seal Kit
- BP-HG: Gun and Hose Set
- BP60-AK: Bung Adaptor Kit suitable for BOP60 pump stems
- BP-HGHV: High Vis Gun and Hose Set
- BP077S: Nozzle dust cap

Applications:

Suitable for use in all industries to replace old style manual operated drum pumps



Part Number	BP60S-OLA	BP60S-OHA
Description	BOP60 Starter kit	High Viscosity BOP60 Starter Kit
Delivery rate*	Up to 3.5L/min**	Min 2L/min**
Oil Drum size	60L	60L
Hook colour	Black	Yellow
On demand flow control	✓	✓
Easy flow control nozzle	✓	✓
Easy portable Powerhead	✓	✓
Self-Priming	✓	✓
Safety lockout carry handle	✓	✓
Sealed Wetted parts	✓	✓
Compatible fluids	Suitable for Oils up to SAE75W90	Suitable for Heavy Oils up to SAE140
Rechargeable Battery	2.0Ah Li-Ion	2.0Ah Li-Ion
Charger	1hr fast	1hr fast

BOP60 For 60 Litre Drums

BATTERY OPERATED PUMP

2
YEARS
MACNAUGHT
WARRANTY*

BP60X-OLA
Pump Stem suitable
for oils up to
SAE75W90



LOW-MID
VISCOSITY
OILS

BP60X-OHA
Pump Stem suitable
for heavy oils up to
SAE140



MID-HIGH
VISCOSITY
OILS

BP60X-ALA
Pump Stem suitable
for ATF



ATF
COMPATIBLE

Part Number	BP60X-OLA	BP60X-OHA	BP60X-ALA
Description	BOP60 Pump Stem Kit	High Viscosity Pump Stem Kit	ATF Pump Stem Kit
Delivery rate*	up to 3.5L/min**	Min 2L/min**	Up to 4.5L/min
Oil Drum size	60L	60L	60L
Hook colour	Black	Yellow	Red
On demand flow control	✓	✓	✓
Easy flow control nozzle	✓	✓	✓
Easy portable Powerhead	✗	✗	✗
Self-Priming	✓	✓	✓
Safety lockout carry handle	✓	✓	✓
Sealed Wetted parts	✓	✓	✓
Compatible fluids	Suitable for Oils up to SAE75W90	Suitable for Heavy Oils up to SAE140	ATF
Rechargeable Battery	✗	✗	✗
Charger	✗	✗	✗

* The delivery rates depend on the type, viscosity the temperature of the fluid.

**SAE40 at 20°C (OLA models) , SAE140 at 20°C (OHA models)

Recommended to be
used with:



BP20-PH
Powerhead
To suit pump
stems.
Battery NOT
included.



BPB-20AH
18VDC-2.0AH
Li-Ion battery



BPC-A
BOP Charger
suited for 2.0AH
Battery (Available
for other countries
- USA, UK, Europe)

MANUAL OIL PUMPS

Hand Operated Oil Pumps

The C7 is a truly a multi-purpose gear oil pump complete with a sliding bung adaptor to fit 15 - 25 litre containers. Delivers 100mls on the down-stroke. Includes 3 different drum adaptors.

10
YEARS
MACNAUGHT
WARRANTY*

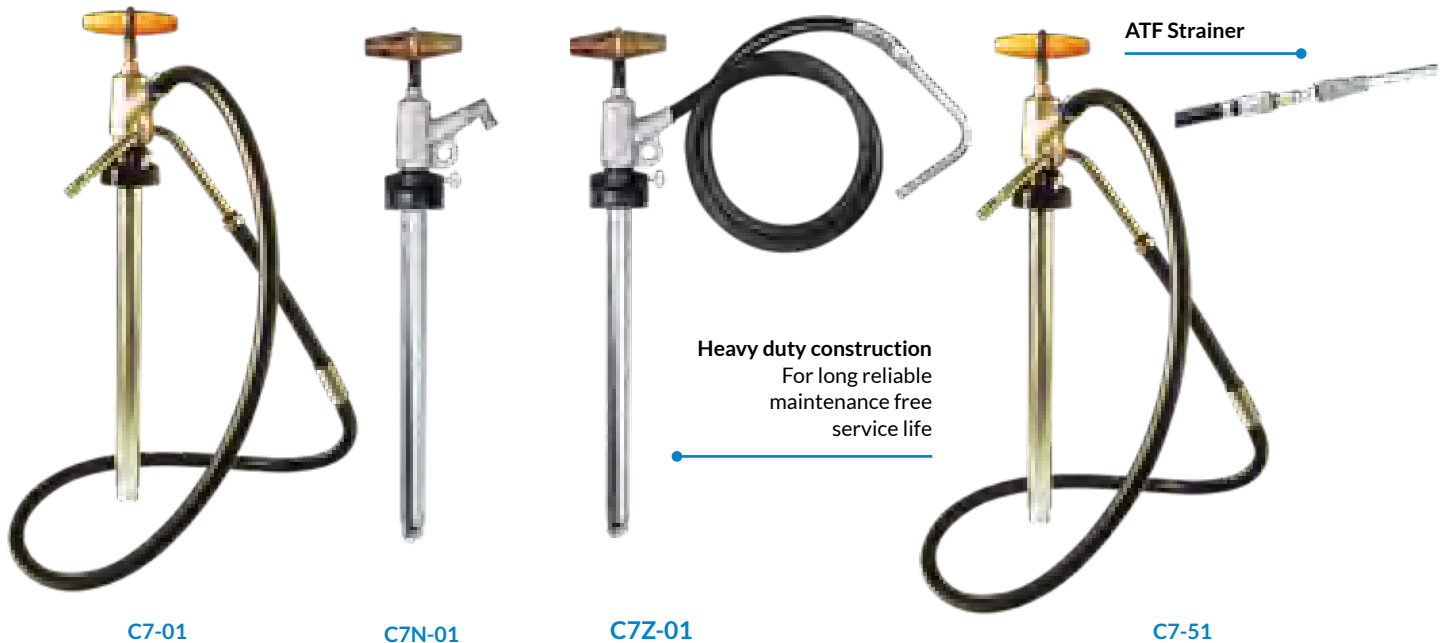

Part Number	C7-01	C7N-01	C7Z-01	C7-51
Description	Multi-Purpose Gear Oil Pump	Multi-Purpose Gear Oil Pump - With Delivery Spout Only	Multi-Purpose Gear Oil Pump - Zinc Version	Multi-Purpose Gear Oil Pump with ATF Strainer
Features	Gear oil pump with hose	Gear oil pump	UG Coal compatible gear oil pump with hose	Gear oil pump with ATF strainer and hose
Pump output	100ml/stroke	100ml/stroke	100ml/stroke	100ml/stroke
Hose	1.8m (70") rubber hose & non drip nozzle	X	1.8m (70") rubber hose & non drip nozzle	1.8m (70") rubber & non drip nozzle
Non drip nozzle	Manual	X	Manual	Manual
Drum size	15L - 25L (4gal - 6.5gal)	15L - 25L (4gal - 6.5gal)	15L - 25L (4gal - 6.5gal)	15L - 25L (4gal - 6.5gal)
Drum adaptor	Multiple Bung Adaptors			
Fully serviceable	✓	✓	✓	✓
Compatible fluids	Kerosene, two stroke mix, lubricating oils to SAE140			
Wetted Parts	Aluminium, steel, viton, delrin and zinc			

Applications:

Ideal for use in any industry where 15-25ltr oil containers are used.

Recommended to be used with:

TR20G
Trolley
(Page 39)



TR5-01
Drum Trolley
(Page 39)



Service Parts

- C7-1K: Seal Kit
- AC24S: Bung Adaptor Set
- AC5S: Foot Valve
- SG88S: Hose and nozzle set

All-Purpose Oil Transfer Pump

The MAOP20 All-Purpose 20L Oil Transfer Pump is designed for dispensing most service fluids including engine, gear, transmission, hydraulic and some engine coolants from 20 - 25L drums. An extendable suction tube and two additional bung adaptors ensure that the expanding range of different size and types of drums are easily catered for.



Easy Prime Pump

Delivery on the down stroke for easy operation

Drain-Back Facility

Allows nozzle to be fixed in non-siphoning position to prevent spillage

Additional Bung Adaptors

Compatible with a wider range of drum and thread types

Anti-Kink Spring
Prevents hose from restricting fluid delivery

1.8m Clear Delivery Hose
Easy identification of fluid type



MAOP20

Part Number	MAOP20
Description	Multi-Purpose Oil pump
Pump output	75ml/stroke
Hose length	1.8m (70") oil resistant hose and non-drip nozzle
Non drip nozzle	Automatic
Drum size	15L - 25L (4gal - 6.5gal)
Drum adaptor	Multiple Bung Adaptors
Compatible fluids	Kerosene, two stroke mix, lubricating oils to SAE140
Wetted Parts	Aluminium, steel, viton, delrin and zinc

Recommended to be used with:



TR20G
Trolley
(Page 39)

TR5-01
Drum Trolley
(Page 39)

MANUAL OIL PUMPS

Hand Operated Suction Gun

The C16 is designed to transfer mineral oils in and out of gearboxes, transfer cases and differentials as well as evacuating sump oil out of an inboard marine engine.

10
YEARS
MACNAUGHT
WARRANTY*



Steel barrel
Durable construction

C16 is great for infield use
For top-ups and extraction

30mm long delivery tube
Access to hard to reach places

C16-01

Part Number	C16-01
Description	Suction Gun - 500ml
Pump output	500ml
Hose length	300mm (12")
Non drip nozzle	X
Drum size	X
Drum adaptor	X
Compatible fluids	Mineral oils to SAE140
Wetted Parts	Nylon11, steel, nitrile, PVC

Applications:

Automotive, Truck and Buses, Farming Equipment, Textile Machinery, Construction and Earthmoving, Forklifts, Military Equipment (e.g. tanks, armoured vehicles), Mining Machinery, Aircraft, Trains

Recommended to be used with:

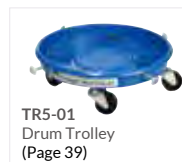

Multi-Purpose Lever Pump

A classic Macnaught hand pump, the A2H MULTI-PURPOSE Drum Pump is the ideal pump for transferring a wide variety of fluids such as diesel fuel, lubricating oils and an extensive range of non-corrosive fluids and chemicals.



Drum Bung Opener
Integrated into pump head casting so additional tools aren't required to open new drums

Telescopic Suction Tube
Supplied with Multiple O'rings Nitrile (fitted), Viton & EPDM, for compatibility with different types of fluids & solvents



A2H

Lever Action Pump
Delivers up to 250ml per stroke

Built-in 2" bung adaptor
To secure pump to drum

1.8m Delivery Hose
Easy to reach difficult applications

Part Number	A2H
Description	Multi-Purpose Lever Pump
Pump output	250ml/stroke
Hose length	1.8m (70") and nozzle
Non drip nozzle	X
Drum size	60L - 205L (16gal - 55gal)
Drum adaptor	2" built in
Compatible fluids	Diesel, lubricating oils to SAE90 and other non-corrosive solvents. To determine liquid compatibility refer to compatibility chart www.macnaught.com.au
Wetted Parts	Aluminium, steel, viton, delrin and zinc

Recommended to be used with:



Service Parts

- A2-1K: Seal Kit

Applications:

Suitable for use in all industries.

MANUAL OIL PUMPS

Lever Action Gear Oil Pump

This pump is supplied complete with a 1.8m delivery hose, and manual non-drip nozzle suitable for 60 – 205L drums. This equipment is fully repairable to provide a much longer service life.

10
YEARS
MACNAUGHT
WARRANTY*

Oils up to
SAE140

Lever Action Pump
Delivers up to 75ml per stroke

2" Sliding Bung Adaptor
To suit different height drums

Two Piece Suction Tube
Adaptable to suit
60L - 205L drums

Manual Non-Drip Nozzle
To prevent fluid spillage

1.8m Delivery Hose
Easy to reach difficult applications



C11-01

Part Number	C11-01
Description	Lever Action Gear Oil Pump
Pump output	75ml/stroke
Hose length	1.8m (70")
Non drip nozzle	Manual
Drum size	60L - 205L (16gal - 55gal)
Drum adaptor	2" sliding
Compatible fluids	Engine oil, gear oils to SAE140, auto trans and hydraulic fluid
Wetted Parts	Nylon11, steel, nitrile, PVC

Recommended to be used with:



TR205-01 Trolley
(Page 39)

Applications:

Suitable for use in all industries.

Service Parts

- **C11-1K:** Overhaul Kit

Spring loaded pumps

These spring loaded oil pumps provide the means to automatically dispense engine and gear oils by simply pressing the oil gun trigger and are ideal for filling gearboxes and diffs. Once primed, a simple press of the trigger delivers oil to the required location.



Press handle
Manually press down to prime

Dispensing Gun
Press trigger to dispense oil

Oil drain back
Means no mess



S20H-01



S60H-01

Oil drain back
Means no mess

1.5m hose
Kink resistant

60L Pump option

Part Number	S20H-01	S60H-01
Description	Spring-Loaded Gear Oil Pump – 20L	Spring-Loaded Gear Oil Pump – 60L
Pump output	340ml/stroke	500ml/stroke
Hose	1.5m kink resistant hose	1.5m kink resistant hose
Dispense gun	✓	✓
Drum size	20L (5gal)	60L (16gal)
Drum bung	✓	✓
ATF filter	✗	✗
Compatible fluids	Engine oil, gear oils to SAE140, auto trans and hydraulic fluid	

Applications:

Ideal for use in all industries where 20ltr or 60ltr oil containers are used.

Recommended to be used with:



Service Parts

For S20H-01 • SA20-1K: Seal Kit • SA11B-1K: Gun Assembly
For S60H-01 • SA60-1K: Seal Kit • SA11B-1K: Gun Assembly

AIR OPERATED OIL PUMPS (T-Series)

OILMASTER® T-Series Air Operated Oil Pump

The OILMASTER® range of ratio stub pumps are high quality, economically priced oil pumps. The ideal choice for small workshop or service truck applications. The "T" series range of oil pumps have been designed with a non corrosive air motor that requires no oil lubrication. The pump has very low air consumption and low noise levels during operation. The T series design includes a built in pressure relief valve to protect against pressure build up caused by thermal expansion. Suitable for oils and premix coolants up to SAE140 viscosity.

10
YEARS
MACNAUGHT
WARRANTY*

**Low Air
Consumption**

Quiet Air Motor design
Meets all industry noise level standards.
Doesn't require air-line lubricator

Brass air inlet (1/4"NPT)
No lubricator required

Durable yet lightweight design
Thermoplastic material with
heavy duty construction

Built in Pressure Relief Valve
To protect against thermal expansion
in the oil system

Low Air Consumption
Smaller compressor and cost
efficient to run

2" sliding bung adaptor
On 3:1 and 5:1 ratio pump models

Oil inlet (1" BSP/NPT)
On all stub pump models



T512S-01

Why choose this product?

A reliable economical pump with a low air consumption and no oil lubricator required

Service Parts

For T112S-01 and T112T-01 models

- T112-1K: Overhaul Kit
- ST003AS: Suction Tube Set

Service Parts

For T312S-01 and T312T-01 models

- T312-1K: Overhaul Kit
- ST003AS: Suction Tube Set

Service Parts

For T512S-01 and T512T-01 models

- T512-2K: Overhaul Kit
- ST003AS: Suction Tube Set

Applications:

Suitable for use in all industries.

OILMASTER® T-Series Air Operated Oil Pumps

10
YEARS
MACNAUGHT
WARRANTY*



T112S-01



T112T-01



T312S-01



T312T-01



T512S-01



T512T-01

Part Number (BSP models)	T112S-01	T112T-01	T312S-01	T312T-01	T512S-01	T512T-01	T512-01-11
Description	Stub Pump	Drum Pump	Stub Pump	Drum Pump	Stub Pump	Drum Pump	Zinc Drum Pump
Pump ratio	1:1 ratio	1:1 ratio	3:1 ratio	3:1 ratio	5:1 ratio	5:1 ratio	5:1 ratio
Output SAE 10*	23L/min (6gal/min)	23L/min (6gal/min)	13L/min (3.5gal/min)	13L/min (3.5gal/min)	11L/min (3gal/min)	11L/min (3gal/min)	11L/min (3gal/min)
Output SAE 15W-40*	22L/min (5.8gal/min)	22L/min (5.8gal/min)	12L/min (3.1gal/min)	12L/min (3.1gal/min)	10L/min (2.6gal/min)	10L/min (2.6gal/min)	10L/min (2.6gal/min)
Output SAE90*	21L/min (5.5gal/min)	21L/min (5.5gal/min)	11L/min (2.9gal/min)	11L/min (2.9gal/min)	9L/min (2.3gal/min)	9L/min (2.3gal/min)	9L/min (2.3gal/min)
Pressure relief valve	✓	✓	✓	✓	✓	✓	✓
2" bung adaptor	✓	✓	✓	✓	✓	✓	✓
Parts guarantee ²	10 Years	10 Years	10 Years	10 Years	10 Years	10 Years	10 Years
Compatible fluids	Engine and gear oils up to SAE90, auto trans, hydraulic fluid and anti-freeze/anti-boil			Engine and gear oils up to SAE140, auto trans, hydraulic fluid and anti-freeze / anti-boil			
Min-Max air pressure	400 - 1030kPa (60 - 150psi)	400 - 1030kPa (60 - 150psi)	400 - 1030kPa (60 - 150psi)	400 - 1030kPa (60 - 150psi)	400 - 1030kPa (60 - 150psi)	400 - 1030kPa (60 - 150psi)	400 - 1030kPa (60 - 150psi)
Min air compressor	0.3m ³ /min (10cfm)	0.3m ³ /min (10cfm)	0.15m ³ /min (5cfm)	0.15m ³ /min (5cfm)	0.15m ³ /min (5cfm)	0.15m ³ /min (5cfm)	0.15m ³ /min (5cfm)
Air inlet	1/4" NPT(F)	1/4" NPT(F)	1/4" NPT(F)	1/4" NPT(F)	1/4" NPT(F)	1/4" NPT(F)	1/4" NPT(F)
Pump outlet	3/4" BSP/NPT(F)	3/4" BSP(F)	3/4" BSP(F)/NPT(F)	3/4" BSP(F)	1/2" BSP/NPT(F)	1/2" BSP(F)	1/2" BSP(F)
Pump inlet	1" BSP (F) /1" NPT (F)	Suction Tube	1" BSP (F) /1" NPT (F)	Suction Tube	1" BSP (F) /1" NPT (F)	Suction Tube	1" BSP (F) /1" NPT (F)
NPT Models			T312-02	T312-02	T512-02	T512-02	

Recommended to be used with:



TB255 Telephonic Suction Tube (Page 77)



TD20-Black Wall bracket (Page 77)



TD-25K Oil feeder hose (use w/ T312) (Page 76)



MOTP1220-01 Twin Ped Oil Reel (Page 103)



OMP415B-01 Oil Reel (Page 121)



Any HG Series Guns (Page 71-73)

AIR OPERATED OIL PUMP PACKAGES

OILMASTER® T-Series Oil Dispensing Kits

The T312THGE-01 pump kit includes a premium quality T312T-01 (3:1) ratio air-operated oil drum pump, 3m (10ft) x 1/2" (12.5mm) oil hose, HG20R-012E-01 electronic metered oil control gun with rigid extension and non-drip nozzle. The kit has an approximate flow rate 8L/min (2.1 US gal/min) with SAE10 oil and is suitable for oils up to SAE140, pre-mix coolants.

10
YEARS
MACNAUGHT
WARRANTY*

HG20R-012E-01

Oil control gun with electronic meter, rigid extension and auto non-drip nozzle

2" Sliding bung adaptor

On 3:1 and 5:1 ratio pump models

Suction tube

To suit 205ltr container

Quiet Air Motor design
Meets all industry noise level standards.
Doesn't require air-line lubricator

T312T-01 (3:1) Ratio oil pump
(No oil lubricator required)

TD-25K (1/2" x 3m)
Oil hose with fittings



T312THGE-01

Why choose this product?

Economically priced with non corrosive air motor and an accurate electronic metered gun

Applications:

Automotive, Truck & Buses, Farming, Construction & Earthmoving, Military, Mining, Aircraft, Trains, Manufacturing, Mining, Aircraft, Trains, Manufacturing

Drum based Oil Dispensing Kits

10
YEARS
MACNAUGHT
WARRANTY*



T112THG-01

T112THGE-01

T312THG-01

T312THGE-01

Part Number	T112THG-01	T112THGE-01	T312THG-01	T312THGE-01
Description	1:1 Ratio Oil Pump Kit with Hose and Unmetred Gun	1:1 Ratio Oil Pump Kit with Hose and Metered Gun	3:1 Ratio Oil Pump Kit with Hose and Unmetred Gun	3:1 Ratio Oil Pump Kit with Hose and Metered Gun
Pump ratio	1:1 ratio	1:1 ratio	3:1 ratio	3:1 ratio
Pump	T112T-01	T112T-01	T312T-01	T312T-01
Outlet hose length	3m (10ft) x 19mm (3/4")	3m (10ft) x 19mm (3/4")	3m (10ft) x 12mm (1/2")	3m (10ft) x 12mm (1/2")
Oil control gun	HG20R-01	HG20R-012E-01	HG20R-01	HG20R-012E-01
Output SAE10*	10L/min (2.6gal/min)	10L/min (2.6gal/min)	8L/min (2.1gal/min)	8L/min (2.1gal/min)
Output 15W-40*	8.5 L/min (2.2gal/min)	8.5 L/min (2.2gal/min)	7 L/min (1.8gal/min)	7 L/min (1.8gal/min)
Output SAE140*	7 L/min (1.8gal/min)	7 L/min (1.8gal/min)	6 L/min (1.6gal/min)	6 L/min (1.6gal/min)
Container	205L (55gal) drum	205L (55gal) drum	205L (55gal) drum	205L (55gal) drum
Airline lubricator	Not required	Not required	Not required	Not required
Pressure relief valve	✓	✓	✓	✓
2" bung adaptor	✓	✓	✓	✓
Compatible fluids	Engine and gear oils up to SAE90, auto trans, hydraulic fluid and anti-freeze / anti-boil		Engine and gear oils up to SAE140, auto trans, hydraulic fluid and anti-freeze / anti-boil	
Max air pressure	1030kPa (150psi)	1030kPa (150psi)	1030kPa (150psi)	1030kPa (150psi)
Min air pressure	400kPa (60psi)	400kPa (60psi)	400kPa (60psi)	400kPa (60psi)
Min air compressor	0.3m ³ /min (10cfm)	0.3m ³ /min (10cfm)	0.15m ³ /min (5cfm)	0.15m ³ /min (5cfm)
Air inlet	1/4" NPT (F)	1/4" NPT (F)	1/4" NPT (F)	1/4" NPT (F)

Recommended to be used with:

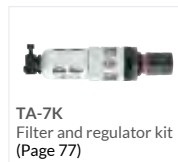
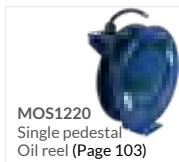

AIR OPERATED OIL PUMPS (R-Series)

R-Series Air Operated Oil Pumps

The 'R' Series range of pumps have been designed and manufactured using a strong metal construction, providing maximum performance and long service life. All the 'R' Series pumps are supplied complete with an in-line air lubricator to help prevent premature wear. Suitable for oils up to SAE140 viscosity and premix coolants. The ideal choice for remote mount or integration into lubrication systems.

10
YEARS
MACNAUGHT
WARRANTY*

**High
Flow**

Long service life

Supplied with In-line lubricator to prevent excess wear and extend service life

Air inlet (1/4"NPT)

Robust and Durable Design

Heavy duty aluminium and steel air motor construction

Sliding bung adaptor (2"BSP)

For all R-Series pump models



R500S-01

Maximize Performance life
Large exhaust ports integrated to prevent icing

Heavy duty construction
For long reliable service life

Oil outlet (3/4"BSPT or NPT)
For all R-Series pump models

Pressure relief valve
On 5:1 ratio pumps only

Oil inlet (1"BSPT or NPT)
On all stub pump models

Why choose this product?

Heavy duty high performance pumps designed for reliability and long service life in the harshest of conditions

Service Parts

- **R100-1K:** R100 Major Service Kit
- **R100-2K:** R100 Seal Kit
- **ST003AS:** Suction Tube Set

Service Parts

- **R300-2K:** R300 Major Service Kit
- **R300-3K:** R300 Seal Kit
- **ST003AS:** Suction Tube Set

Service Parts

- **R500-2K:** R500 Major Service Kit
- **R500-3K:** R500 Seal Kit
- **ST003AS:** Suction Tube Set

Service Parts

- **R1000-1K:** R1000 Major Service Kit
- **R1000-2K:** R1000 Seal Kit
- **ST003AS:** Suction Tube Set

Applications:

Installations where there are long distance and high flow requirements.

R-Series Ratio Air Operated Oil Pumps

10
YEARS
MACNAUGHT
WARRANTY*

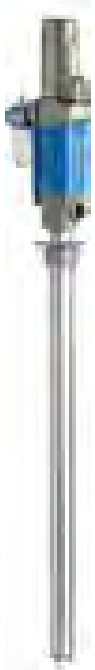

R100T-01



R300S-01



R300T-01



R500S-01



R500T-01



R1000S-01



R1000T-01

Part Number (BSP Models)	R100T-01	R300S-01	R300T-01	R500S-01	R500T-01	R1000S-01	R1000T-01
Description	Drum Pump	Stub Pump	Drum Pump	Stub Pump	Drum Pump	Stub Pump	Drum Pump
Pump ratio	1:1 ratio	3:1 ratio	3:1 ratio	5:1 ratio	5:1 ratio	10:1 ratio	10:1 ratio
Output SAE 10*	60L/min (16gal/min)	23L/min (6gal/min)	23L/min (6gal/min)	32L/min (8.5gal/min)	32L/min (8.5gal/min)	18L/min (4.8gal/min)	18L/min (4.8gal/min)
Output SAE 15W-40*	45L/min (12gal/min)	19L/min (5gal/min)	19L/min (5gal/min)	30L/min (8gal/min)	30L/min (8gal/min)	17L/min (4.5gal/min)	17L/min (4.5gal/min)
Output SAE 90*	43L/min (11.3gal/min)	18L/min (4.8gal/min)	18L/min (4.8gal/min)	28L/min (7.3gal/min)	28L/min (7.3gal/min)	15L/min (4gal/min)	15L/min (4gal/min)
Airline lubricator	✓	✓	✓	✓	✓	✓	✓
Pressure relief valve	✗	✗	✗	✓	✓	✗	✗
2" bung adaptor	✓	✓	✓	✓	✓	✓	✓
Compatible fluids	Engine and gear oils up to SAE90(R100T) and SAE140(all other models), auto trans and hydraulic fluid, diesel						
Min-Max air pressure	400-1030kPa (60/150psi)	400-1030kPa (60/150psi)	400-1030kPa (60/150psi)	400-1030kPa (60/150psi)	400-1030kPa (60/150psi)	400-1030kPa (60/150psi)	400-1030kPa (60/150psi)
Air inlet	1/4" NPT(F)	1/4" NPT(F)	1/4" NPT(F)	1/4" NPT(F)	1/4" NPT(F)	1/4" NPT(F)	1/4" NPT(F)
Pump outlet	3/4" BSP(F) / 3/4" NPT (F)	3/4" BSP(F) / 3/4" NPT (F)	3/4" BSP(F) / 3/4" NPT (F)	3/4" BSP(F) / 3/4" NPT (F)	3/4" BSP(F) / 3/4" NPT (F)	3/4" BSP(F) / 3/4" NPT (F)	3/4" BSP(F) / 3/4" NPT (F)
Pump inlet	Suction Tube	1" BSP(F) / 1" NPT (F)	Suction Tube	1" BSP(F) / 1" NPT (F)	Suction Tube	1" BSP(F) / 1" NPT (F)	Suction Tube
Min air compressor	0.22m³/min (8cfm)	0.16m³/min (6cfm)	0.16m³/min (6cfm)	0.3m³/min (10cfm)	0.3m³/min (10cfm)	0.5m³/min (18cfm)	0.5m³/min (18cfm)
NPT Models	R100T-02	R300S-02	R300T-02	R500S-02		R1000S-02	

Recommended to be used with:



AIR OPERATED OIL DRUM PUMP PACKAGES

R-Series 3:1 Ratio Oil Dispensing Kit

The R-Series oil pump kits include a premium oil drum pump, 3m (10ft) x 1/2" (12.5mm) oil hose, option of metered or non-metered oil control gun, with rigid extension and non-drip nozzle. Supplied with In-line lubricator to prevent excess wear and extend service life.

10
YEARS
MACNAUGHT
WARRANTY*

Robust and Durable Design
Heavy duty aluminium and steel
air motor construction

TD-25K - Oil Hose and Fittings
1/2"x3m feeder hose to suit R-Series
3:1 ratio pump

Maximize Performance life
Large exhaust ports integrated
to prevent icing

**HG20R-012E-01 Oil
control gun**
With electronic meter,
rigid extension and
auto non-drip nozzle

Premium Quality R series Pump
R300T-01 - 3:1 ratio oil drum pump

TA-3K Oil lubricator
To keep the air motor free from
corrosion and reduce seal wear

Heavy duty construction
For long reliable service life

2" Sliding bung adaptor
For all 3:1 and 5:1 ratio pumps

Suction tube
To suit 205ltr container



R300THGE-01

Why choose this product?

The R series oil pump system kits are the ideal solution for reliable 205ltr drum oil dispensing

Applications:

Automotive, Truck and Buses, Farming, Construction and Earthmoving, Military, Mining, Aircraft, Trains

Drum based Oil dispensing kits

10
YEARS
MACNAUGHT
WARRANTY*



R100THG-01



R100THGE-01



R300THG-01



R300THGE-01

Part Number	R100THG-01	R100THGE-01	R300THG-01	R300THGE-01
Description	1:1 Ratio Oil Pump Kit with Hose and Unmetered Gun	1:1 Ratio Oil Pump Kit with Hose and Metered Gun	3:1 Ratio Oil Pump Kit with Hose and Unmetered Gun	3:1 Ratio Oil Pump Kit with Hose and Metered Gun
Pump ratio	1:1 ratio	1:1 ratio	3:1 ratio	3:1 ratio
Pump	R100T-01	R100T-01	R300T-01	R300T-01
Outlet hose length	3m (10ft) x 19mm (3/4")	3m (10ft) x 19mm (3/4")	3m (10ft) x 12mm (1/2")	3m (10ft) x 12mm (1/2")
Oil control gun	HG20R-01	HG20R-012E-01	HG20R-01	HG20R-012E-01
Output SAE10*	12L/min (3.1gal/min)	12L/min (3.1gal/min)	12L/min (3.1gal/min)	12L/min (3.1gal/min)
Output 15W-40*	9L/min (2.4gal/min)	9L/min (2.4gal/min)	9L/min (2.4gal/min)	9L/min (2.4gal/min)
Output SAE140*	8L/min (2.1gal/min)	8L/min (2.1gal/min)	8L/min (2.1gal/min)	8L/min (2.1gal/min)
Container	205L (55gal) drum	205L (55gal) drum	205L (55gal) drum	205L (55gal) drum
Airline lubricator	✓	✓	✓	✓
2" bung adaptor	✓	✓	✓	✓
Compatible fluids	Oils up to SAE90 (1:1 pumps) and SAE140 (3:1 pumps), automatic trans fluid, engine oil, gear oil, hydraulic oil, diesel, kerosene, anti-freeze/anti-boil			
Max air pressure	1030kPa (150psi)	1030kPa (150psi)	1030kPa (150psi)	1030kPa (150psi)
Min air pressure	400kPa (60psi)	400kPa (60psi)	400kPa (60psi)	400kPa (60psi)
Min air compressor	0.22m ³ /min (8cfm)	0.22m ³ /min (8cfm)	0.16m ³ /min (6cfm)	0.16m ³ /min (6cfm)
Air inlet	1/4" NPT (F)	1/4" NPT (F)	1/4" NPT(F)	1/4" NPT(F)

Recommended to be used with:

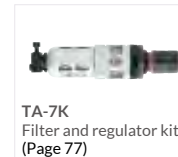

AIR OPERATED OIL DRUM PUMP PACKAGES

R-Series Trolley Based Oil Dispensing Systems

This premium quality portable trolley based oil systems designed suit 205L oil drums. The systems include metered or non metered oil control gun, OMP415B 1/2" x 15m oil reel 3:1 ratio air operated oil pump ('R' series) and a 250ltr drum trolley complete with all fittings and hoses. This quality oil system has been designed and manufactured to give you many years of reliable trouble free service.

10
YEARS
MACNAUGHT
WARRANTY*

Premium Quality Oil Control Gun on all models

Cast aluminium body with automatic and non drip nozzle

Models with electronic Metered control gun
Model HG20R012E-01 gives clean and simple dispensing oil with a meter accuracy of +/-0.5%

3:1 R Series Pump
R300S-01 model provides high performance and longer life.

Feeder hose
1/2"x1m Single wire braid feeder hose with suction spear and fittings

Premium Quality R3 Retractable Reel
OMP415B-01 Oil Reel comes with 15m x 1/2" oil hose

Heavy Duty Trolley
TR2015-01 Trolley suitable for 205L drums



OS100GE-01

*205L drum not included

Wheel Lock
For added safety and stability

Kit Parts:

- **TR205** Trolley (available only with following kits: OS100G-01, OS100GE-01, OS100B-01, OS100T-01 and OS100TE-01)
- **R300S-01** Oil pump
- **OMP415B-01** Oil reel (available only with following kits: OS100G-01, OS100B-01, OS100S-01 and OS100SE-01)
- **HG20R-012E-01** Electronic oil gun (available only with following kits: OS100GE-01, OS100TE-01 and OS100SE-01)
- **HG20R-01** Rigid Extension oil gun (available only with following kits: OS100G-01, OS100T-01 and OS100S-01)
- Includes all fittings

Why choose this product?

The ideal solution for portable and reliable 205ltr drum oil dispensing

Applications:

Suitable for use in all industries where portable oil dispensing is required

Trolley Based Oil Dispensing Systems

10
YEARS
MACNAUGHT
WARRANTY*



OS100G-01



OS100T-01



OS100S-01

Part Number	OS100G-01	OS100GE-01	OS100T-01	OS100TE-01	OS100S-01	OS100SE-01
Description	3:1 R-Series Pump with Retractable reel, Trolley and Unmetred Gun	3:1 R-Series Pump with Retractable reel, Trolley and Metered Gun	3:1 R-Series Pump with Trolley and Unmetred Gun	3:1 R-Series Pump with Trolley and Metered Gun	3:1 R-Series Pump with Retractable Reel and Unmetred Gun	3:1 R-Series Pump with Retractable Reel and Metered Gun
Part Number - Without Gun	OS100B-01		X	X	X	X
Pump ratio	3:1 ratio	3:1 ratio	3:1 ratio	3:1 ratio	3:1 ratio	3:1 ratio
Pump	R300S-01	R300S-01	R300S-01	R300S-01	R300T-01	R300T-01
Oil Control Gun	HG20R-01	HG20R-012E-01	HG20R-01	HG20R-012E-01	HG20R-01	HG20R-012E-01
Outlet hose length/ reel	Retractable OMP415B - 15m x 12.5mm oil hose	Retractable OMP415B - 15m x 12.5mm oil hose	X	X	Retractable OMP415B - 15m x 12.5mm oil hose	Retractable OMP415B - 15m x 12.5mm oil hose
Trolley	TR205	TR205	TR205	TR205	X	X
Output SAE10*	11L/min (2.9gal/min)	11L/min (2.9gal/min)	11L/min (2.9gal/min)	11L/min (2.9gal/min)	11L/min (2.9gal/min)	11L/min (2.9gal/min)
Output 15W-40*	9L/min (2.4gal/min)	9L/min (2.4gal/min)	9L/min (2.4gal/min)	9L/min (2.4gal/min)	9L/min (2.4gal/min)	9L/min (2.4gal/min)
Output SAE80W-90*	5L/min (1.3gal/min)	5L/min (1.3gal/min)	5L/min (1.3gal/min)	5L/min (1.3gal/min)	5L/min (1.3gal/min)	5L/min (1.3gal/min)
Container	205L (55gal) drum	205L (55gal) drum	205L (55gal) drum	205L (55gal) drum	205L (55gal) drum	205L (55gal) drum
Airline lubricator	✓	✓	✓	✓	✓	✓
Pressure relief valve	Built in	Built in	Built in	Built in	Built in	Built in
2" bung adaptor	✓	✓	✓	✓	✓	✓
Compatible fluids	Oils up to SAE140 including automatic transmission fluid, engine oil, gear oil, hydraulic oil, diesel, kerosene and anti-freeze/anti-boil					

Recommended to be used with:

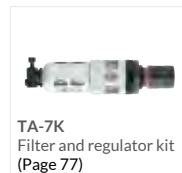
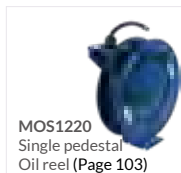

AIR OPERATED OIL DRUM PUMP PACKAGES

T-Series Trolley Based Oil Dispensing Systems

This premium quality portable trolley based oil systems designed suit 205L oil drums. The systems include metered or non metered oil control gun, OMP415B 1/2"x 15m oil reel 3:1 ratio air operated oil pump ('T' series) and a 250ltr drum trolley complete with all fittings and hoses. This quality oil system has been designed and manufactured to give you many years of reliable trouble free service.

10
YEARS
MACNAUGHT
WARRANTY*



Kit Parts:

- **TR205** Trolley (available only with following kits: OS50G-01, OS50GE-01, OS50B-01, OS50T-01 and OS50TE-01)
- **T312T-01** Oil pump
- **OMP415B-01** Oil reel (available only with following kits: OS50G-01, OS50B-01, OS50S-01 and OS50SE-01)
- **HG20R-012E-01** Electronic oil gun (available only with following kits: OS50GE-01, OS50TE-01 and OS50SE-01)
- **HG20R-01** Rigid Extension oil gun (available only with following kits: OS50G-01, OS50T-01 and OS50S-01)
- Includes all fittings

Why choose this product?

Peace of mind reliability

Applications:

Suitable for use in all industries where portable oil dispensing is required

Trolley Based Oil Dispensing Systems



OS50G-01

OS50T-01

OS50S-01

Part Number	OS50G-01	OS50GE-01	OS50T-01	OS50TE-01	OS50S-01	OS50SE-01
Description	3:1 T-Series Pump with Retractable reel, Trolley and Unmetered Gun	3:1 T-Series Pump with Retractable reel, Trolley and Metered Gun	3:1 T-Series Pump with Trolley and Unmetered Gun	3:1 T-Series Pump with Trolley and Metered Gun	3:1 T-Series Pump with Retractable Reel and Unmetered Gun	3:1 T-Series Pump with Retractable Reel and Metered Gun
Part Number - Without Gun	OS50B-01		X	X	X	X
Pump ratio	3:1 ratio	3:1 ratio	3:1 ratio	3:1 ratio	3:1 ratio	3:1 ratio
Pump	T312T-01	T312T-01	T312T-01	T312T-01	T312T-01	T312T-01
Oil Control Gun	HG20R-01	HG20R-012E-01	HG20R-01	HG20R-012E-01	HG20R-01	HG20R-012E-01
Outlet hose length/ reel	Retractable OMP415B - 15m x 12.5mm oil hose	Retractable OMP415B - 15m x 12.5mm oil hose	X	X	Retractable OMP415B - 15m x 12.5mm oil hose	Retractable OMP415B - 15m x 12.5mm oil hose
Trolley	TR205	TR205	TR205	TR205	X	X
Output SAE10*	7L/min (1.8gal/min)	7L/min (1.8gal/min)	7L/min (1.8gal/min)	7L/min (1.8gal/min)	7L/min (1.8gal/min)	7L/min (1.8gal/min)
Output 15W-40*	6L/min (1.6gal/min)	6L/min (1.6gal/min)	6L/min (1.6gal/min)	6L/min (1.6gal/min)	6L/min (1.6gal/min)	6L/min (1.6gal/min)
Output SAE 80W-90*	5L/min (1.3gal/min)	5L/min (1.3gal/min)	5L/min (1.3gal/min)	5L/min (1.3gal/min)	5L/min (1.3gal/min)	5L/min (1.3gal/min)
Container	205L (55gal) drum	205L (55gal) drum	205L (55gal) drum	205L (55gal) drum	205L (55gal) drum	205L (55gal) drum
Airline lubricator	Not required	Not required	Not required	Not required	Not required	Not required
Pressure relief valve	Built In	Built In	Built In	Built In	Built In	Built In
2" bung adaptor	✓	✓	✓	✓	✓	✓

Recommended to be used with:

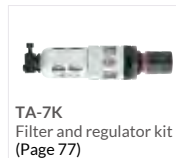

AIR OPERATED OIL - IBC SYSTEMS

IBC OR POD MOUNTED OIL DISPENSING SYSTEM

The IBC or POD Mounted Oil Dispensing System uses either a R series or T series ratio oil pump, capable of handling a wide range of viscosity fluids. It comes supplied with a solid hot dipped galvanised base frame, 3:1 or 5:1 ratio oil pump, heavy duty 1/2" x 10m or 15m oil reel, with an option of metered or non metered oil control gun with holster and complete kit with all fittings and hoses.

10
YEARS
MACNAUGHT
WARRANTY*



Twin pedestal metal reel
MOTP1215 (15m x 1/2")

5:1 Ratio Pump
Available as R or T series ensures
performance & reliability

Fittings and connectors

Hot dipped galvanised base plate
To secure all components
of the system

R-Series pump model shown

Why choose this product?

This premium quality IBC oil dispensing system provides a complete dispensing system in one neat package.

Applications:

Truck and buses, constructions earthmoving, large oil transfer applications.

Kit Parts:

- **5:1 Ratio T-Series Oil Pump**
- **IM012E-01** Electronic Meter
(available on following kits:
OS900IM-01 and OS950IM-01)
- **HG20R-012E-01** Electronic oil
gun (available on following kits:
OS900GE-01 and OS950GE-01)
- **HG20R-01** Rigid Extension oil
gun (available on following kits:
OS900IM-01, OS950G-01 and
OS950IM-01)
- **MOTP1215-01** 15m x 1/2" Twin
Pedestal Oil Reel
- Includes all fittings

R-SERIES IBC/POD MOUNTED OIL DISPENSING SYSTEM



Also available with T-Series pumps

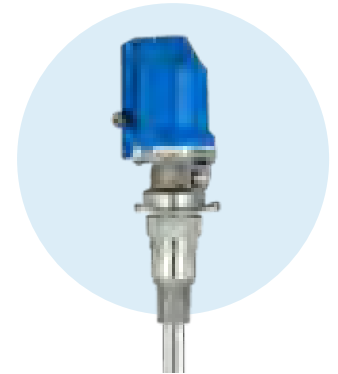

OS950IM-01

Part Number	OS900G-01	OS900GE-01	OS900IM-01	OS950G-01	OS950GE-01	OS950IM-01
Description	System with T-Series 5:1 pump, reel and unmetred gun	System with T-Series 5:1 pump, reel and metred gun	System with T-Series 5:1 pump, reel and in-line meter	System with R-Series 5:1 pump, reel and unmetred gun	System with R-Series 5:1 pump, reel and metred gun	System with R-Series 5:1 pump, reel and in-line meter
Part Number without Gun	OS900-01 (System with T series 5:1 Pump and Reel)			OS950-01 (System with R Series 5:1 Pump and Reel)		
Pump ratio	5:1 ratio	5:1 ratio	5:1 ratio	5:1 ratio	5:1 ratio	5:1 ratio
Pump	T512S-01	T512S-01	T512S-01	R500S-01	R500S-01	R500S-01
Hose reel length	15m (50ft)	15m (50ft)	15m (50ft)	15m (50ft)	15m (50ft)	15m (50ft)
Oil control gun	HG20R-01	HG20R-012E-01	HG20R-01	HG20R-01	HG20R-012E-01	HG20R-01
In-Line Meter	None	None	IM012E-01	None	None	IM012E-01
Output SAE10*	8L/min (2.1gal/min)	8L/min (2.1gal/min)	8L/min (2.1gal/min)	12L/min (3.1gal/min)	12L/min (3.1gal/min)	12L/min (3.1gal/min)
Output 15W-40*	7L/min (1.8gal/min)	7L/min (1.8gal/min)	7L/min (1.8gal/min)	10L/min (2.6gal/min)	10L/min (2.6gal/min)	10L/min (2.6gal/min)
Output SAE140*	6L/min (1.6gal/min)	6L/min (1.6gal/min)	6L/min (1.6gal/min)	8L/min (2.1gal/min)	8L/min (2.1gal/min)	8L/min (2.1gal/min)
Container	1000L (264gal) IBC	1000L (264gal) IBC	1000L (264gal) IBC	1000L (264gal) IBC	1000L (264gal) IBC	1000L (264gal) IBC
Airline lubricator	Not required	Not required	Not required	✓	✓	✓
Pressure relief valve	Built in	Built in	Built in	Built in	Built in	Built in
2" bung adaptor	✓	✓	✓	✓	✓	✓
Compatible fluids	Oils up to SAE140, automatic trans fluid, engine oil, gear oil, and hydraulic oil, diesel, kerosene, anti-freeze/anti-boil					

Recommended to be used with:

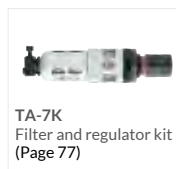
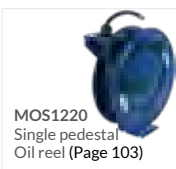

AIR OPERATED OIL - IBC SYSTEMS

IBC OR POD MOUNTED OIL DISPENSING SYSTEM

The IBC or POD Mounted Oil Dispensing System uses either a R series or T series ratio oil pump, capable of handling a wide range of viscosity fluids. It comes supplied with a powder coated steel mounting plate, 3:1 or 5:1 ratio oil pump, heavy duty 1/2" x 10m or 15m oil reel, with an option of metered or non metered oil control gun with holster and complete kit with all fittings and hoses.

10
YEARS
MACNAUGHT
WARRANTY*

3:1 T Series Pump

T312T-01 model provides high quality, durable, efficient and economical proposition

Premium Quality Retracta R3 Reel

OMP415B-01 Oil Reel comes with 15m x 1/2" oil hose



Feeder hose
1/2"x1m single wire braided feeder hose with suction spear and fittings

Wall Mount Plate

This heavy duty kit can be mounted or directly attached to an IBC or Bulk tank

OS400G-01

**Economical
side fitting
system**

Why choose this product?

This premium quality IBC oil dispensing system provides a complete dispensing system in one neat package.

Applications:

Truck and buses, constructions earthmoving, large oil transfer applications.

Kit Parts:

- **3:1 Ratio T-Series Oil Pump**
- **HG20R-012E-01** Electronic oil gun (available on following kits: OS400TE-01)
- **HG20R-01** Rigid Extension oil gun (available on following kits: OS400G-01 and OS400T-01)
- **OMP415B-01** 15m x 1/2" Oil Reel (available on following kits: OS400G-01, OS400B-01 and OS500B-01)
- Includes all fittings

IBC or pod mounted oil dispensing systems

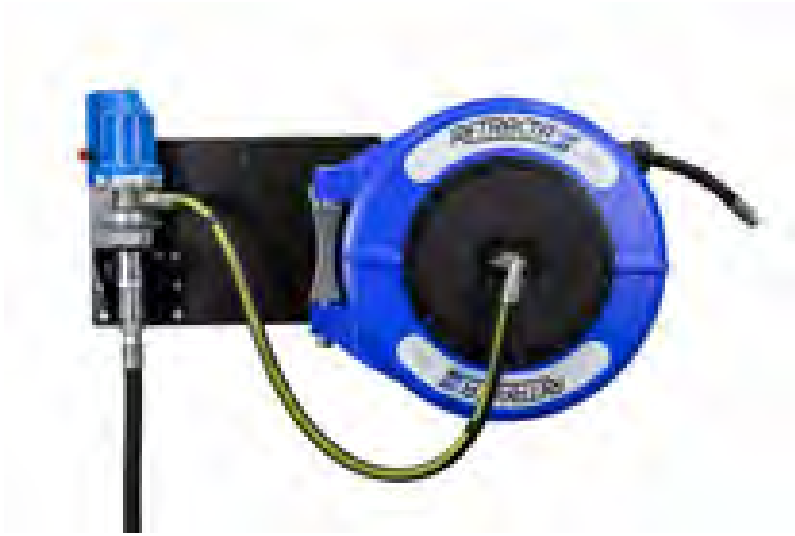

OS400B-01



OS400T-01

Part Number	OS400G-01	OS400B-01	OS400T-01	OS400TE-01	OS500B-01
Description	IBC/Pod Mounted 3:1 T-SERIES Pump, with Reel and Unmetered Gun	IBC/Pod Mounted 3:1 T-SERIES Pump with reel without Gun	IBC/Pod Mounted 3:1 T-SERIES Pump with Unmetered Gun without Reel	IBC/Pod Mounted 3:1 T-SERIES Pump with Metered Gun without Reel	IBC/Pod Mounted 3:1 R-SERIES Pump with Reel and without Gun
Pump ratio	3:1 ratio	3:1 ratio	3:1 ratio	3:1 ratio	3:1 ratio
Pump	T312S-01	T312S-01	T312S-01	T312S-01	R300S-01
Oil Control Gun	HG20R-01	X	HG20R-01	HG20R-012E-01	X
Outlet hose length/reel	Retracta OMP415B - 15mx1/2"	Retracta OMP415B - 15mx1/2"	6m x1/2" Hose	6m x1/2" Hose	Retracta OMP415B - 15mx1/2"
Output SAE10*	8L/min (2.1gal/min)	8L/min (2.1gal/min)	8L/min (2.1gal/min)	8L/min (2.1gal/min)	12L/min (3.1gal/min)
Output 15W-40*	7L/min (1.8gal/min)	7L/min (1.8gal/min)	7L/min (1.8gal/min)	7L/min (1.8gal/min)	9L/min (2.4gal/min)
Output SAE80W-90*	5L/min (1.3gal/min)	5L/min (1.3gal/min)	5L/min (1.3gal/min)	5L/min (1.3gal/min)	8L/min (2.1gal/min)
Container	1000L (264gal) IBC	1000L (264gal) IBC	1000L (264gal) IBC	1000L (264gal) IBC	1000L (264gal) IBC
Airline lubricator	Not required	Not required	Not required	Not required	✓
Pressure relief valve	Built In	Built In	Built In	Built In	X
2" bung adaptor	✓	✓	✓	✓	✓
Compatible fluids	Oils up to SAE140, automatic trans fluid, engine oil, gear oil, and hydraulic oil, diesel, kerosene, anti-freeze/anti-boil				
Min/Max Air Pressure	400kPa (60psi) - 1030kPa (150psi)				

Recommended to be used with:



OIL CONTROL GUNS

Non-Metered Oil Control Guns

The Reliable HG20 oil gun is ideal for all types of workshops and automotive dealership applications. The HG20 is designed with a trigger lock on the handle and is supplied complete with flexible extension and automatic non drip nozzle.

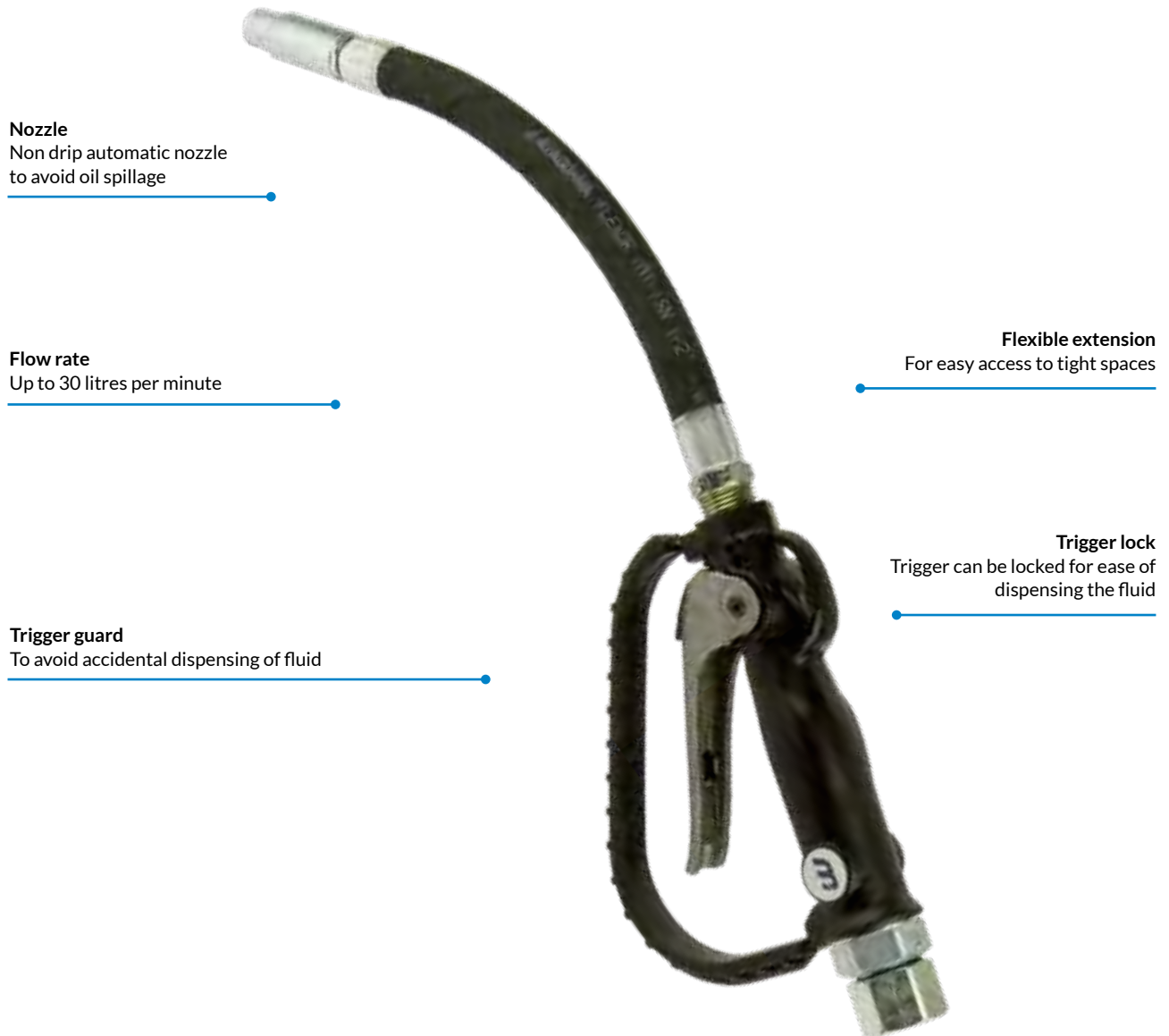

HG20F-01

Why choose this product?

Peace of mind reliability.

Package Includes:

- HG20 oil control gun
- Flexible Extension
- Automatic non-drip nozzle

Service Parts

- HG20-1K: Gun Seal Kit

Applications:

Suitable for use in most oil dispensing systems

NON-METERED CONTROL GUNS

10
YEARS
MACNAUGHT
WARRANTY*



HG20R-01



HG20F-01



CCG-01

Part Number (BSP models)	HG20R-01	HG20F-01	CCG-01
Description	Rigid Extension	Flexible Extension	Coolant Control Gun
Flow range	Up to 30L/min (8gaL/min)	Up to 30L/min (8gaL/min)	Up to 30L/min (8gaL/min)
Inlet swivel	1/2" BSP(F)	1/2" BSP (F)	1/2" BSP inlet with 3/8" BSP adaptor
Non drip nozzle	✓	✓	✗
Latching trigger	✓	✓	✓
Fully serviceable	✓	✓	✗
Compatible fluids	Engine and gear oils up to SAE140, auto trans, hydraulic fluid, diesel, premix coolant (max 50%)		Coolant
Max working pressure	6900kPa (1000psi)	6900kPa (1000psi)	2500kPa (365psi)
Max working temp	70°C (158°F)	70°C (158°F)	70°C (158°F)
Wetted Materials	Acetal, Aluminium, Steel, Nitrile rubber		
Weight	0.8kg (1.8lb)	0.8kg (1.8lb)	0.8kg (1.8lb)
Extension type	Rigid	Flexible	Rigid
NPT Models	HG20R-02	HG20F-02	

Recommended to be used with:

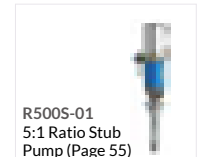
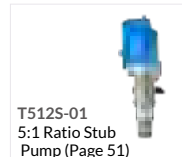

OIL CONTROL GUNS - METERED

Metered Oil Control Guns

The Reliable HG20 oil gun is fitted with a digital meter and is ideal for all types of workshops and automotive dealership applications. The HG20 is designed with a trigger lock on the handle and is supplied complete with flexible extension and automatic non drip nozzle. The meter accuracy is +/- 0.5% of reading.

10
YEARS
MACNAUGHT
WARRANTY*

Nozzle

Non drip Automatic nozzle
to avoid oil spillage

Straight Flexible Extension

For easy access to tight spaces

Trigger Guard

To avoid accidental dispensing of fluid

Accurate electronic meter

+/- 0.5% of reading

Electronic Flow meter

6-digit digital display resettable
batch totaliser, resettable and
non-resettable total

Trigger lock

Trigger can be locked for ease of
dispensing the fluid



HG20F-012E-01

Why choose this product?

Peace of mind reliability.

Package Includes:

- HG20 oil control gun
- IM012E electronic meter
- Flexible Extension
- Automatic non-drip nozzle

Service Parts

- HG20-1K: Gun Seal Kit

Applications:

Suitable for use in most oil
dispensing systems

CONTROL GUNS - METERED



HG20R-012E-01



HG20F-012M-01



HG20F-012E-01

Part Number (BSP models)	HG20R-012E-01	HG20F-012M-01	HG20F-012E-01
Description	Electronic meter with Rigid Extension	Mechanical meter with Flexible Extension	Electronic meter with Flexible Extension
Flow range	Up to 25L/min (6.6gal/min)	Up to 25L/min (6.6gal/min)	Up to 25L/min (6.6gal/min)
Inlet swivel	1/2" BSP(F)	1/2" BSP (F)	1/2" BSP(F)
Meter (oval gear)	Electronic	Mechanical	Electronic
Meter Accuracy	+/- 0.5%	+/- 1%	+/- 0.5%
Min/Max Temp	14°C (6.8°F) - 55°C (131°F)	14°C (6.8°F) - 55°C (131°F)	14°C (6.8°F) - 55°C (131°F)
Features	6 digit totaliser	7 digit totaliser	6 digit totaliser
Extension	Rigid with non-drip nozzle	Flexible with non-drip nozzle	
Latching Trigger	✓	✓	✓
Compatible Fluids	Engine, gear, ATF, hydraulic oils up to SAE140 viscosity & anti-freeze/anti boil		
Max Working Pressure	6, 900 kPa (1, 000 psi)	6, 900 kPa (1, 000 psi)	6, 900 kPa (1, 000 psi)
Weight (with fittings)	1.5Kg (3.3lb)	1.5Kg (3.3lb)	1.5Kg (3.3lb)
NPT Models	HG20R-012E-02		HG20F-012E-02

Recommended to be used with:



OMP415B-01
Retracta R3 Oil Reel
(Page 121)



MOS1220
Single pedestal
Oil reel (Page 103)



FHO1215-01
F Series Oil Reel
(Page 133)



T512S-01
5:1 Ratio Stub
Pump (Page 51)



R500S-01
5:1 Ratio Stub
Pump (Page 55)

OIL CONTROL GUNS

High flow oil control guns

High volume oil control gun with flexible extension and manual non-drip nozzle. Fitted with trigger guard locking trigger and full flow 3/4" inlet swivel. Up to 10, 350 kPa (1, 500 psi) maximum working pressure. Flow rate up to 57L/min (15 US gal/min). The Manual nozzle allows full flow with minimum pressure drop.

10
YEARS
MACNAUGHT
WARRANTY*

Up to
57
L/min

Nozzle

Non drip Manual nozzle to avoid oil spillage

Straight Flexible extension

Flexible extension for easy access to tight spaces

Trigger guard

To avoid accidental dispensing of fluid

Trigger Lock

Lockable trigger for ease of dispensing the fluid

High Volume

High volume gun suited to bulk dispensing of most types of service fluids used in mining or large workshops

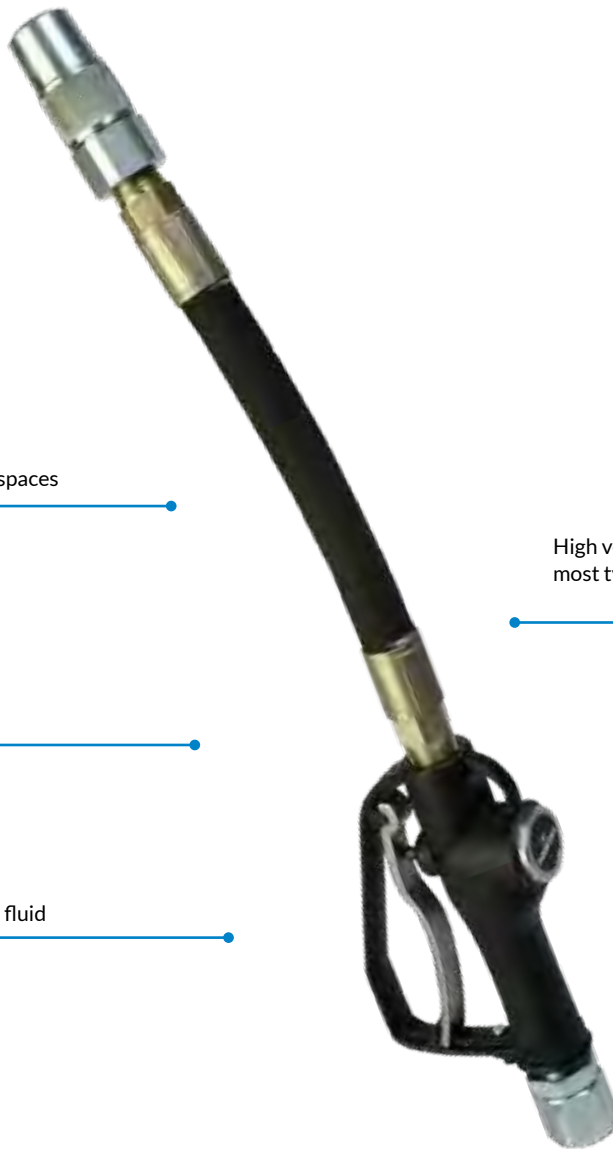

HG100-01

Why choose this product?

Robust cast aluminium or zinc body designed for minimal pressure loss at high flow rates.

Package Includes:

- HG100 Handle
- Flexible extension
- Full flow manual non-drip nozzle

Service Parts

- HG100-1K Gun Service Kit

Applications:

Suitable for any high flow oil dispensing application

High flow oil control guns



HG100-01

HG100B-01

HG100-01-11

HG100-019E-01

Part Number (BSP models)	HG100-01	HG100B-01	HG100-01-11	HG100-019E-01
Description	High Flow Oil Control Gun	High Flow Oil Control Gun without Non-Drip Nozzle	High Flow Oil Control Gun (Zinc)	High Flow Oil Control Gun with Electronic Meter
Flow range	Up to 57L/min (15gal/min)	Up to 57L/min (15gal/min)	Up to 57L/min (15gal/min)	3 - 57 L/min (0.8-15 gal/min)
Inlet swivel	3/4" BSP (F)	3/4" BSP (F)	3/4" BSP (F)	3/4" BSP (F)
Meter	X	X	X	Oval gear / Digital
Meter accuracy	X	X	X	+/- 0.5% (lube oils)
Features	Hi-Flow. Heavy duty design. Trigger Guard for hand protection. Balanced valve assembly for max flow control.	Hi-Flow. Heavy duty design. Trigger Guard for hand protection. Balanced valve assembly for max flow control.	Hi-Flow (Zinc model). Heavy duty design. Trigger Guard for hand protection. Balanced valve assembly for max flow control.	Includes all HG100 Standard features plus 6-digit digital display, resettable batch totaliser, resettable and non resettable totals, flow rate mode, with protective shroud.
Extension	Flexible	Flexible	Flexible	Flexible
Non drip nozzle	Manual	X	Manual	Manual
Latching trigger	✓	✓	✓	✓
Compatible fluids	Oils up to SAE140, automatic trans fluid, engine oil, gear oil, hydraulic oil, coolant			
Max working pressure	10 350kPa (1500psi)		10 350kPa (1500psi)	10 350kPa (1500psi)
NPT Models	HG100-02			HG100-019E-02

Recommended to be used with:

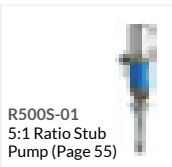
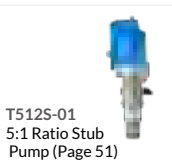

OIL CONTROL GUNS - METERED

Control Guns - Metered (HG series)

Top of the range presettable electronic oil control gun with rigid extension. Features include locking trigger and non-drip nozzle, 5 presettable totals, resettable batch total and a non-resettable total. The meter accuracy is +/- 0.5 % of reading, working pressures up to 1500psi (10, 350kPa) and flow rates from 1 to 30L/min (4 to 8 US gal/min) the gun features self correcting algorithm.

10
YEARS
MACNAUGHT
WARRANTY*

**Premium
Preset
Oil Gun**

All models include automatic non-drip nozzle
With unique thermal expansion piston to prevent annoying drips

Proven oval gear accuracy
Self correcting algorithm for highest accuracy

Ergonomic handles
Incorporating latching trigger mechanism for a positive release

Accurate electronic meter
+/- 0.5% of reading

5 presettable totals
Offers 5 different dispense memory settings for common delivery volumes

Heavy duty construction
To deliver industry leading strength and durability



HG55-01

Why choose this product?

Tough unit construction with cast aluminium chassis, providing both efficient ergonomics and solid protection of internals against damage.

Applications:

Suitable for use on most oil installations

Service Parts

- **HG50-1K:** Major Service Kit (HG55/HG60)
- **HG50-2K:** Valve Service Kit (HG40/HG55/HG60)
- **HG040AS:** HG40, HG50, HG60 Swivel Assembly
- **HG370AS:** HG60 Preset Module (for HG60)
- **HG369AS:** HG55 Electronic Module (for HG55)
- **HG200AS:** HG40 Register Assembly (for HG40)

Control Guns - Metered (HG series)



HG40-01



HG55-01



HG60-01

Part Number (BSP models)	HG40-01	HG55-01	HG60-01
Description	Oil Control Gun with Mechanical Meter	Oil Control Gun with Mechanical Meter	Oil Control Gun with Preset Electronic Meter
Flow range	1-30 L/min (0.26 - 8 gal/min)	1-30 L/min (0.26 - 8 gal/min)	1-30 L/min (0.26 - 8 gal/min)
Inlet swivel	1/2" BSP (F)	1/2" BSP (F)	1/2" BSP (F)
Meter	Oval gear / mechanical	Oval gear / digital	Oval gear / digital
Meter accuracy (Flow rate)	+/- 1% (lube oils)	+/- 0.5% (lube oils)	+/- 0.5% (lube oils)
Features	4-digit resettable batch totaliser 6-digit accumulative totaliser	5-digit resettable batch totaliser 6-digit accumulative totaliser sleep mode to conserve battery life EEPROM information retention for battery change	Pre-settable to 1999.9ltrs, AUTO Shut-off 5-digit resettable batch totaliser 6-digit accumulative totaliser sleep mode to conserve battery life EEPROM information retention for battery change
Operating temperature	0°C - 50°C (32°F-122°F)	0°C - 50°C (32°F-122°F)	0°C - 50°C (32°F-122°F)
Maximum pressure	1,500psi (10,350kPa)	1,500psi (10,350kPa)	1,500psi (10,350kPa)
Extension	Rigid	Rigid	Rigid
Non drip nozzle	Automatic	Automatic	Automatic
Latching trigger	✓	✓	✓
NPT Models	HG40-02	HG55-02	HG60-02

Recommended to be used with:



OMP415B-01
Retracta R3 Oil Reel
(Page 121)



T512S-01
5:1 Ratio Stub
Pump (Page 51)

IN-LINE OIL FLOW METERS

Electronic Oil Meter - 1/2" BSP/NPT

In-line oval gear meter with electronic register designed to accurately measure lubricating oils. Flow rate up to 30L/min (8 US gal/min), with an accuracy of +/- 0.5% of reading and a maximum pressure rating up to 6,900 kPa (1,000psi). The meter has a large LC display with both batch and cumulative totals. Fitted with either 1/2" BSP / NPT(F) ports.

10
YEARS
MACNAUGHT
WARRANTY*

Accuracy

Accurate reading to +/-0.5% with maximum pressure to 6,900kPa (1,000psi)

Large display
Digital display showing both cumulative & push-button reset batch totals



1/2" BSP or NPT Ports

Suitable for most oil applications

Resettable batch total 6-digit digital display resettable batch totaliser, resettable and non-resettable totals

IM012E-01

Why choose this product?

Economic, accurate and reliable electronic flow meter.

Service Parts

- See pages [227](#), [228](#) and [229](#)

Applications:

Suitable for in line oil line applications or added to oil control gun

In-line Oil Meters



IM012E-01



IM019E-01



IM012M-01



IM012P-01



IM019P-01

Part Number (BSP models)	IM012M-01	IM012E-01	IM012P-01	IM019E-01	IM019P-01
Description	Mechanical Oil Meter - 1/2"	Electronic Oil Meter - 1/2"	Pulse Oil Meter - 1/2"	Electronic Oil Meter - 3/4"	Pulse Oil Meter - 3/4"
Flow range	1-30 L/min (0.26 - 8 gal/min)	1-30 L/min (0.26 - 8 gal/min)	1-30 L/min (0.26 - 8 gal/min)	3 - 80L/min (0.8 - 21 gal/min)	3 - 80L/min (0.8 - 21 gal/min)
Maximum pressure	1,000psi (6,900kPa)	1,000psi (6,900kPa)	1,000psi (6,900kPa)	1,000psi (6,900kPa)	1,000psi (6,900kPa)
Maximum temperature	55°C (131°F)	55°C (131°F)	55°C (131°F)	55°C (131°F)	55°C (131°F)
Meter / register	Oval gear / Mechanical	Oval gear / Digital	Oval gear / Pulse output	Oval gear / Digital	Oval gear / Pulse output
Accuracy (flow rate)	+/- 1% (lube oils)	+/- 0.5% (lube oils)	+/- 0.5% (lube oils)	+/- 0.5% (lube oils)	+/- 0.5% (lube oils)
Features	4-digit resettable batch totaliser 7-digit accumulative totaliser	6-digit digital display resettable batch totaliser	Pulse output model includes 1m fly lead either reed switch and/or hall effect sensor	6-digit digital display resettable and non resettable totals	Pulse output model includes 1m fly lead either reed switch and/or hall effect sensor
Protective shroud	✓	✓	✓	✓	✓
Inlet port	1/2" BSP (F)	1/2" BSP (F)	1/2" BSP (F)	3/4" BSP (F)	3/4" BSP (F)
Outlet port	1/2" BSP (F)	1/2" BSP (F)	1/2" BSP (F)	3/4" BSP (F)	3/4" BSP (F)
Compatible fluids	Oils up to SAE140, automatic trans fluid, engine oil, gear oil, hydraulic oil, coolant, diesel, kerosene				
NPT Models	IM012M-02	IM012E-02	IM012P-02	IM019E-02	IM019P-02

Recommended to be used with:



HG20R-01
Oil Control Gun
(Page 67)



HG100-01
High Flow Oil Gun
(Page 71)



R500S-01
R and T Series Oil
Pumps (Page 55)

OIL ACCESSORIES

12
MONTH
MACNAUGHT
WARRANTY*



FLEXIBLE EXTENSION - 10" WITH AUTO NOZZLE

HGFNZ

250mm (10") flexible extension with automatic non-drip nozzle for HG40/HG55/HG60 oil control guns



RIGID EXTENSION - 6" HGREX

150mm (6") Rigid extension for several types of oil control guns. Replacement unit for HG40/55/60



FLEXIBLE EXTENSION - 10" WITHOUT NOZZLE

HGFEX

250mm (10") Flexible extension for oil control guns. Replacement unit for HG40/55/60



RIGID EXTENSION WITH NON-DRIP NOZZLE

HGRNZ

150mm (6") ridged extension with automatic non-drip nozzle for HG40/HG55/HG60 oil control guns



AUTOMATIC NON-DRIP NOZZLE

HGNZL

Fully automatic non-drip nozzle using unique patented technology. Standard equipment on all HG40/55/60

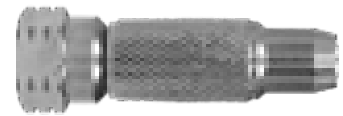

MANUAL NON-DRIP NOZZLE

HGMNZL

Manual non-drip nozzle 1/4" NPT (F) to suit most brands of oil control guns

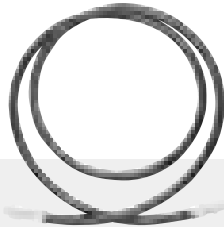

OIL FEEDER HOSE TB-20K 5:1 RATIO

TB-20K

Feeder hose - 3.0m (10ft) x 12.5mm (1/2") i.d. - 6900kPa (1000psi). 3/4" BSP (M) swivel x 1/2" BSP (M) fitting with 3/4" reducer. Suitable for R-Series™ & OILMASTER® in 5:1 & 10:1 ratio pumps

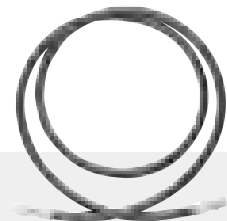

OIL FEEDER HOSE TD-25K 3:1 RATIO

TD-25K

Feeder hose - 3.0m (10ft) x 12.5mm (1/2") i.d. - 2,800kPa (400psi). 3/4" BSP (M) swivel x 1/2" BSP (M) fitting with 3/4" reducer. Suitable for R-Series™ & OILMASTER® in 3:1 ratio pumps



IN-LINE FILTER/STRAINER

CF

Fine mesh strainer to fit C7 or C11 pumps. Highly recommended when dispensing either ATF or hydraulic oils to trap small particles



REMOTE SUCTION KIT - DRUM

RSK-DRUM

2.4m (8ft) hose, fittings & suction tube to suit drum bung mounting



ON/OFF AIR VALVE SETS

TA16S

Reliable on/off air valve for use with air operated grease and oil pumps



WALL MOUNT BRACKET
TD20-BLACKS

Wall mounting bracket for air operated oil pumps. Uses standard 2" bung adaptor connection. Suits all R-Series™ and OILMASTER® oil pumps



TELESCOPIC SUCTION TUBE
TB25S

1" BSP (M), length 615 - 1035mm (24" - 40"). Suits all Macnaught 'R' and 'T' series stub pumps



REMOTE SUCTION KIT - IBC
RSK-IBC

2.4m (8ft) hose, fittings, & 3" connector to suit IBC bottom outlet



LUBRICATOR KIT
TA-3K

¼" Airline lubricator used to add oil into airline to lubricate and protect pumps from corrosion and seal wear. Suits all R-Series™ and oil pumps

WALL MOUNT KIT (BRACKET ONLY)
TA-2K

A bracket set to join the TA-7K filter/regulator & the TA-3K lubricator together to form a neat unit (Bracket only). Note: Lubricators shown are for illustration purposes only



FILTER AND REGULATOR KIT
TA-7K

¼" Airline filter and regulator kit. Used to regulate the air pressure to the air operated equipment as well as remove dust, dirt & moisture from the air supply



QUICK RELEASE AIRLINE FITTING KIT
TA-5K

A snap on connector for easy connection of air powered equipment to the airline. Thread size: 1/4" BSP.



STRAIGHT FLEXIBLE EXTENSION WITH AUTO NOZZLE
HGFFNZ

250mm (10") flexible extension with automatic non-drip nozzle for HG40/HG55/HG60 oil control guns



DRUM TROLLEY - 20L
TR5-01

Drum trolley for 20kg (44lb) grease drums and 20L (5gal) oil drums



DRUM TROLLEY - 60L
TR6-01

Drum trolley for 55Kg (120lb) grease drums and 60L (16gal) oil drums



TROLLEY
TR205-01

Heavy duty trolley designed to suit drums up to 205L (54gal) and 180kg (400lb). Large main wheels with a steerable braked third wheel. Very low loading height

MANUAL FUEL PUMPS

RAPIDFLO™ Rotary Fuel Pump

The GT RAPIDFLO™ is a high performance rotary impeller pump suitable for transferring diesel, ULP, aviation fuels, kerosene & light oils (up to SAE30). The RAPIDFLO™ is capable of transfer rates of 800ml per revolution (up to 100L/min depending on viscosity) from 60-205L drums and tanks. The impeller and gearbox design allows extremely fast fuel delivery.

10
YEARS
MACNAUGHT
WARRANTY*

Hi-Flo
100
L/min



Robust aluminium housing
Screwed together for ease of service and maintenance

Lockable handle
And nozzle holder for security

High flow rate
With close to one litre per revolution

Built in strainer

2.4m Anti-Static Rubber Hose
Compatible with unleaded petrol and aviation fuel*

Suction Tube
(3 piece) with sliding bung adaptor to suit various size drums

GT-01

Why choose this product?

The ultimate pump for manual high flow fuel delivery.

Applications:

Ideal for most high flow fuel transfer applications

Service Parts

- GP-1K: Body Set
- GM-1K: Service Kit
- GR34S: Bung Adaptor Set

RAPIDFLO™ Rotary Fuel Pumps



RAPIDFLO™ with Filter
GTF-01
 VA-01 filter included



RAPIDFLO™ with Filter and Wrench
GT-01/WRENCH
 VA-01 filter and L-DWA wrench included



RAPIDFLO™ with Filter and Meter
GTFM-01
 HA1S-01 Filter, DM100-01 Meter and fittings included



Part Number	GT-01	GT-01BD	GT-01/WRENCH	GTF-01	GTFM-01
Description	RAPIDFLO™ Rotary Fuel Pump	RAPIDFLO™ Rotary Fuel Pump - Biodiesel Version	RAPIDFLO™ with Filter and Wrench	RAPIDFLO™ with Filter	RAPIDFLO™ with Filter and Meter
Pump output	0.8L/rev (typical delivery rate 100L/min (26GAL))				
Action	Bi-lobe rotary	Bi-lobe rotary	Bi-lobe rotary	Bi-lobe rotary	Bi-lobe rotary
Hose	2.4m anti-static rubber hose				
Drum size	205L (54 gal)	205L (54 gal)	205L (54 gal)	205L (54 gal)	205L (54 gal)
Drum adaptor	2" Sliding	2" Sliding	2" Sliding	2" Sliding	2" Sliding
Lockable handle	✓	✓	✓	✓	✓
Nozzle holder	✓	✓	✓	✓	✓
Built in strainer	✓	✓	✓	✓	✓
Compatible Fluids	Diesel, ULP, aviation fuels, kerosene, lubricating oils to SAE30	Biodiesel, kerosene and lubricating oils to SAE30	Diesel, ULP and kerosene		
Wetted Components	Aluminium, steel, zinc, nitrile, rubber and viton				
Filter	X	X	VA-01	VA-01	HA1S-01
Drum Wrench	X	X	L-DWA	X	X
Meter	X	X	X	X	DM100-01
Connector Kit	X	X	X	X	DV-01

Recommended to be used with:



VA-01 Fuel Filter Kit (Page 100)



DM100-01 Mechanical Fuel Meter (Page 96)



DV-01 Connector Kit (Page 100)

MANUAL FUEL PUMPS

ROTARY VANE PUMP

An economical rotary pump designed to dispense diesel, kerosene and lubricating oils up to 20L (5 US gal) per minute from 60L (16 US gal) to 205L (55 US gal) drums. This self-priming pump has been designed to reliably dispense diesel, kerosene and oils up to SAE90 at flow rates of up to 20L/min. Including a built in nozzle holder and lockable handle for added security, the ROTARY VANE PUMP is an excellent choice for quick, reliable oil transfer.



Nozzle holder

To stop siphoning between uses

Adjustable Bung Adaptor

To handle both 205 & 60 litre drums

Self Priming

Easy to prime by rotating handle

Quick, effortless delivery of fluids
Rotary action delivers up to 20L/min in both directions



RVP-01

Why choose this product?

Ideal for fast oil or diesel transfer.

Applications:

Suitable for all industries where fast oil and diesel transfer is required.

Service Parts

- RVP-1K: Seal Kit

ROTARY VANE PUMPS

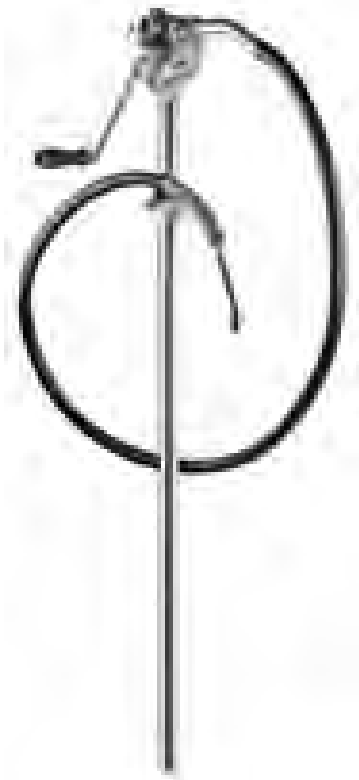

RVP with Filter
RVPF-01
VA-01 filter included



RVP with Filter and Meter
RVPFM-01
HA1S-01 Filter, DM100-01 Meter and fittings included



Part Number	RVP-01	RVPF-01	RVPFM-01
Description	Rotary Vane Pump	Rotary Vane Pump with Filter	Rotary Vane Pump with Filter & Meter
Pump output	Typical delivery rate 20L/min(5gal/min)	Typical delivery rate 20L/min(5gal/min)	Typical delivery rate 20L/min(5gal/min)
Action	Rotary	Rotary	Rotary
Hose	1.8m (6ft) PVC/Nitrile hose	1.8m (6ft) PVC/Nitrile hose	1.8m (6ft) PVC/Nitrile hose
Drum size	60L - 205L (16-54 gal)	60L - 205L (16-54 gal)	60L - 205L (16-54 gal)
Drum adaptor	2" Sliding	2" Sliding	2" Sliding
Lockable handle	✓	✓	✓
Nozzle holder	✓	✓	✓
Built in strainer	✓	✓	✓
Compatible Fluids	Diesel and kerosene (filters not suitable for aviation fuels)		
Wetted Components	Aluminium, steel, zinc and nitrile rubber		
Filter	X	VA-01	HA1S-01
Meter	X	X	DM100-01
Connector Kit	X	X	DV-01

Recommended to be used with:



VA-01
Fuel Filter Kit
(Page 100)



DM100-01
Mechanical Fuel Meter
(Page 96)



DV-01 (for RVP-01)
(Page 100)

ELECTRIC FUEL PUMPS

Electric Diesel Pump Kits

Ideal for portable diesel transfer applications including bulk tank, service truck or utility vehicle applications, these 12/24V ELECTRIC DIESEL PUMP KITS are an economical alternative to manual pumps. These self-priming vane pumps are fitted with a built-in bypass valve and deliver up to 40L/min (free flow) and have a 30 minute duty cycle. The pumps are supplied complete with everything needed for the operator to start transferring diesel. For the best control and accuracy, it is recommended to use the appropriate Macnaught digital diesel meter and filter.



Portable 40L/min Diesel Pump
Available in 12V or 24V models

Pump Package
Includes nozzle, suction hose, delivery hose and fittings

Manual or automatic nozzle
Options available to suit different conditions



Why choose this product?

Premium quality electric diesel pump kits. Complete kit ready to go.

Applications:

Ideal for use on any diesel transfer application.

Service Parts

- **AFP12-1K:** Pump Service Parts
- **AFP12-2K:** Poppet Valve Kit
- **A40LPM-SWITCH:** On/Off Switch

12V / 24V Electric Diesel Pump Kits



**12V ELECTRIC DIESEL PUMP KIT
MANUAL NOZZLE
AFP12M**



**12V ELECTRIC DIESEL PUMP
KIT AUTOMATIC NOZZLE
AFP12A**

Part Number	AFP12M	AFP12A	AFP24M	AFP24A
Description	12V Electric Diesel Pump Kit Manual Nozzle	12V Electric Diesel Pump Kit Auto Nozzle	24V Electric Diesel Pump Kit Manual Nozzle	24V Electric Diesel Pump Kit Auto Nozzle
Flow range	40L/min (11 gal/min)	40L/min (11 gal/min)	40L/min (11 gal/min)	40L/min (11 gal/min)
Volt	12V	12V	24V	24V
Inlet/ Outlet	3/4" BSP (F)	3/4" BSP (F)	3/4" BSP (F)	3/4" BSP (F)
Duty Cycle	30min	30min	30min	30min
Suction hose	25mm (1") x 2m (6.5ft)	25mm (1") x 2m (6.5ft)	25mm (1") x 2m (6.5ft)	25mm (1") x 2m (6.5ft)
Delivery hose	19mm (3/4") x 4m (13ft) power cable with alligator clips	19mm (3/4") x 4m (13ft) power cable with alligator clips	19mm (3/4") x 4m (13ft) power cable with alligator clips	19mm (3/4") x 4m (13ft) power cable with alligator clips
Suitable fluids	*Suitable for diesel use only			

Recommended to be used with:



ADTFM
Digital Fuel Meter
(Page 97)



ATS205
Telescopic Suction
Tube (Page 100)

ELECTRIC FUEL PUMPS

12V High Flow Wall Mount Diesel Pump Kit

The 12V WALL MOUNT KIT is ideal for portable diesel transfer including bulk tank, service truck or utility vehicle applications. This 60 litres per minute pump is supplied with a high flow 12V pump, mechanical flow meter, 4m delivery hose and an automatic nozzle. Easily mountable next to a bulk diesel tank or onto service trucks, this kit is the perfect solution for high flow or high volume diesel transfer.



12V High flow Automatic Diesel Pump Kit

The pump kit is designed to reliably transfer diesel (only). The pump is a self priming, positive displacement, rotary vane pump operating on 12V DC. The pump will deliver up to 85 litres per minute, has a built-in bypass valve. The motor has a 30 minute duty cycle. The pumps are supplied complete with everything needed for the operator to start transferring diesel. For the best control and accuracy, it is recommended to use the appropriate Macnaught digital diesel meter and filter.

60LPM
AHFP12A

Easy operation
Fitted with automatic nozzle

12V DC pump
Heavy duty pump

Pre-cripped fittings
For ease of assembly



Mechanical meter large easy to read display
4-digit resettable and calibrator

Fully assembled
Easily mountable, heavy duty plate

Why choose this product?

Premium high flow electric 12 volt diesel pump kit, supplied with accurate mechanical flow meter, auto nozzle, and wall mount plate, ideal for remote mounting to service trucks or similar use.

85LPM
AHFP85L-12A



Part Number	AHFP12A	AHFP85L-12A
Description	12V High Flow Wall Mount Diesel Pump Kit	12V High Flow Automatic Diesel Pump Kit
Flow range	60L/min (16gal/min)	85L/min (22.5gal/min)
Volt	12V	12V
Inlet/ Outlet	1" BSPP (F)	1" BSP (F)
Nozzle	Automatic	Automatic
Duty Cycle	30 Min	30 Min
Suction hose	25mm (1") x 2m (6.5ft)	25mm (1") x 2m (6.5ft)
Delivery hose	19mm (3/4") x 4m (13ft)	25mm (1") x 4m (13ft)
Suitable fluids	*Suitable for diesel use only	
Meter included	✓	X
Wall mount	✓	X

Applications:

Ideal for use for any diesel transfer applications

Recommended to be used with:



ADTFM
Digital Fuel Meter
(Page 97)



ATS205
Telescopic Suction
Tube (Page 100)

Service Parts for AHFP12A

- AHFP12A-1K: Pump Service Parts
- AHFP12A-2K: Poppet Valve Kit
- AHF-SWITCH: On/Off Switch

Service Parts for AHFP85L-12A

- AHFP85L-1K: Pump Service Parts

240V High Flow Diesel Pumps

Macnaught offers a range of 240V HIGH FLOW DIESEL PUMPS. These self-priming rotary vane pumps are equipped with a fan cooled motor, built-in bypass valve, stainless steel filter and a cast iron body with anti-corrosion coating. These sturdy pumps ensure reliability and a long service life.



240V heavy duty pump
Heavy duty construction for long life and reliability

Self priming
Instant reliable delivery



70LPM
AHFP70LPM

Fan cooled
Prevents Overheating

Ready to use
Supplied with electric cable and 240V plug



100LPM
AHFP100LPM



150LPM
AHFP150LPM

Why choose this product?

Quality range of high flow 240Volt electric diesel pumps, ideal for all types of diesel transfer applications.

Part Number	AHFP70LPM	AHFP100LPM	AHFP150LPM
Description	240V High Flow Diesel Pump 70LPM	240V High Flow Diesel Pump 100LPM	240V High Flow Diesel Pump 150LPM
Flow range	70L/min (18.5gal/min)	100L/min (26gal/min)	150L/min (40gal/min)
Volt	240V	240V	240V
Inlet/ Outlet	1" BSPP (F)	1" BSPP (F)	1" BSPP (F)
Max current draw	2.3 Amps with IP55 motor protection	4.1 Amps with IP55 motor protection	14.5 Amps with IP55 motor protection
Duty Cycle	Continuous	30min	30min
Suitable fluids	*Suitable for diesel use only		

Service Parts for AHFP70LPM

- AHFP70LPM-1K: Wet Seal Kit
- AHFP70LPM-2K: Poppet Valve Kit
- AHF70LPM-CAP: Capacitor
- AHF-SWITCH: On/Off Switch

Service Parts for AHFP100LPM

- AHFP100LPM-1K: Wet Seal Kit
- AHFP100LPM-2K: Poppet Valve Kit
- AHF100LPM-CAP: Capacitor
- AHF-SWITCH: On/Off Switch

Service Parts for AHFP150LPM

- AHFP100LPM-1K: Wet Seal Kit
- AHFP100LPM-2K: Poppet Valve Kit
- AHF100LPM-CAP: Capacitor
- AHF-SWITCH: On/Off Switch

Recommended to be used with:



ADTFM
Digital Fuel Meter
(Page 97)



ATS205
Telescopic Suction
Tube (Page 100)



AMFM (for 70 &
100LPM models)
Mechanical Fuel Meter
(Page 96)

Applications:

Ideal for use for any diesel transfer applications

ELECTRIC FUEL PUMPS

240V Diesel Mini Bowser

The Macnaught range of 240V Diesel Mini Bowsers offer the operator new options when looking for robust construction that deliver consistently higher flow rates. These compact units come as complete packages that allow delivery rates up to 100 L/min. Equipped with easy to use, accurate mechanical register that can be calibrated on-site, these units also offer smart on/off switches integrated into the nozzle holder. Extremely versatile, the bowsers can be installed directly to the wall or any suitable structure.



Resettable fill totaliser
4-digit resettable

Non-resettable accumulative totaliser
8-digit accumulative total

Hose hanger
Allows for neat hose storage

Automatic nozzle
with delivery hose

Built-in on/off switch
Pump protection from overheating

Long fuel hose
Long hose provides access to hard to reach fuel fill points

Why choose this product?

Complete diesel dispensing unit, ideal for high use applications. The built in meter provides accurate recording of fuel usage, with the use of a micro switch the pump will switch off when nozzle is replaced into holder.

Service Parts for AMB100L

- AHFP100LPM-1K: Wet Seal Kit
- AHFP100LPM-2K: Poppet Valve Kit
- AHF100LPM-CAP: Capacitor
- AHF-SWITCH: On/Off Switch

Service Parts for AMB60L

- AHFP70LPM-1K: Wet Seal Kit
- AHFP70LPM-2K: Poppet Valve Kit
- AHF70LPM-CAP: Capacitor
- AHF-SWITCH: On/Off Switch

Part Number	AMB100L	AMB100L-6M	AMB60L
Description	240V Diesel Mini Bowser - 100L	240V Diesel Mini Bowser - 100L 6m hose	240V Diesel Mini Bowser - 60L
Flow range	100L/min (26gal/min)	100L/min (26gal/min)	60L/min (16gal/min)
Volt	240V	240V	240V
Inlet/ Outlet	1" BSP (F)	1" BSP (F)	1" BSP (F)
Nozzle	Automatic	Automatic	Automatic
Hose length	4 metres	6 metres	4 metres
Duty Cycle	30 Min	30 Min	30 Min
Suction hose	25mm (1") x 2m (6.5ft)	25mm (1") x 2m (6.5ft)	25mm (1") x 2m (6.5ft)
Delivery hose	25mm (1") x 4m (13ft)	25mm (1") x 6m (19.6ft)	25mm (1") x 4m (13ft)
Suitable fluids	*Suitable for diesel use only	*Suitable for diesel use only	*Suitable for diesel use only

240V UREA/DEF IBC Dispensing Kit

Easily mountable in a workshop environment, the 240V UREA/DEF IBC DISPENSING KIT is ideal for fast and easy transfer of Urea/DEF. This unit includes a high quality, self-priming vane pump with built-in bypass valve offering superior cool running and a 30 minute duty cycle with flow rates up to 40L/min. The pump kit is supplied with an IBC mounting plate, nozzle holder and manual nozzle.



Easy installation
Fully assembled easy mountable heavy duty plate

240V AC pump
Heavy duty pump with 2m power cord



Easy storage
Built in nozzle holder for neat storage

Easy dispensing
Manual nozzle for easy dispensing of Urea/DEF

Delivery hose
8m delivery/suction hose (cut to suit)

Why choose this product?

This premium quality IBC UREA/DEF dispensing system provides a complete dispensing system in one neat package.

Service Parts

- **AUP240-1K:** Pump Service Parts
- **AUP240-2K:** Poppet Valve Kit

Part Number	AUP240
Description	240V Urea/DEF IBC Dispensing Kit
Flow range	40L/min (11gal/min)
Volt	240V AC Pump
Inlet/ Outlet	3/4" BSP (F)
Nozzle	Manual
Duty Cycle	30 Min
Delivery/Suction hose	19mm (3/4") x 8m (26ft)
Suitable fluids	*Suitable for Urea/DEF and water

Recommended to be used with:



ADTUM
Digital UREA/DEF
Meter (Page 97)

Applications:

Truck and buses, constructions earthmoving, large oil transfer applications.

AIR OPERATED DIAPHRAGM PUMPS

Air Operated Diaphragm Pumps

Heavy duty yet lightweight and easy to operate, these diaphragm pumps are designed to provide continuous flow. These double diaphragm air operated pumps offer a great solution for clean and dirty liquids, particularly waste oils, as they are particle tolerant. These pumps are compatible with oils (new & used), engine coolants RTU (new & used), oily water and diesel.

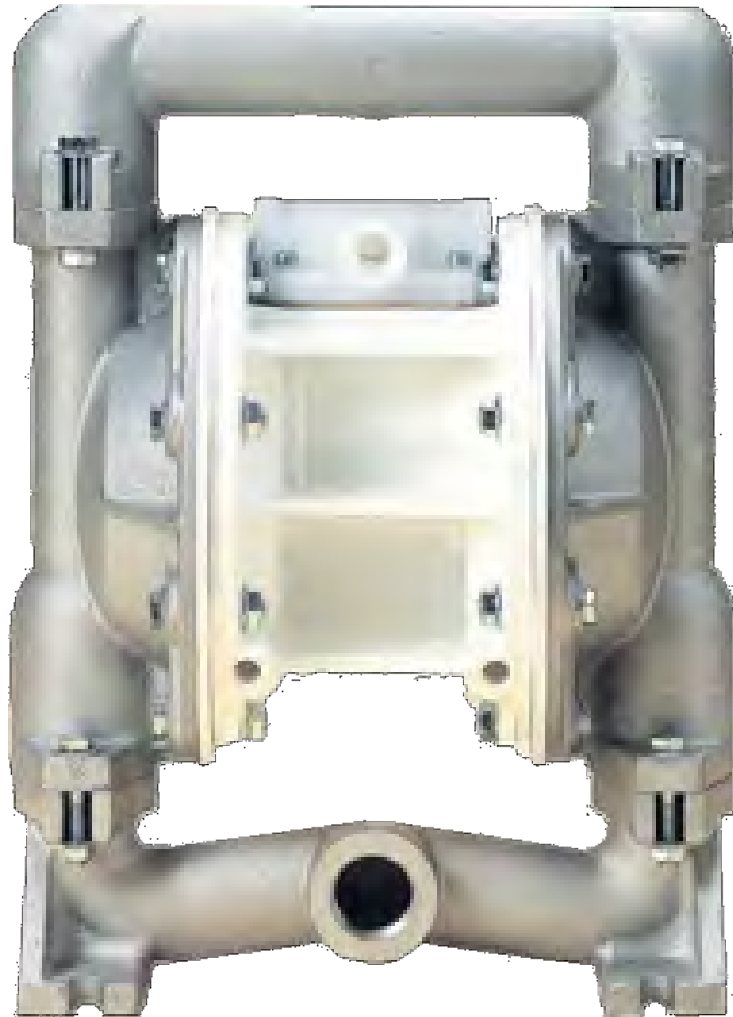

High flow rate
Low pressure loss and fast reliable fluid delivery

Particle tolerant
Ideal for waste oils and contaminated fluids

Heavy duty construction
Long life and reliability

Exhaust muffler
To reduce noise level

Service Parts available
For peace of mind

DDP19

Why choose this product?

Ideal for the efficient transfer of diesel, new and waste oils, as well as most contaminated automotive fluids.

Applications:

Automotive, Truck and Buses, Farming, Construction and Earthmoving, Military, Mining, Aircraft, Trains

Air Operated Diaphragm Pumps



DDP13



DDP19



DDP25



DDP38



DDP50

Part Number	DDP13	DDP19	DDP25	DDP38	DDP50
Description	1/2" Diaphragm Pump	3/4" Diaphragm Pump	1" Diaphragm Pump	1 1/2" Diaphragm Pump	2" Diaphragm Pump
Max air pressure	100psi (690kPa)	100psi (690kPa)	100psi (690kPa)	100psi (690kPa)	100psi (690kPa)
Inlet/outlet	1/2" NPT (F)	3/4" NPT (F)	1" BSP (F)	1 1/2" BSP (F) / 1 1/4" BSP (F)	2" BSP (F)
Air inlet	3/8" NPT (F)	3/8" NPT (F)	1/2" NPT (F)	1/2" NPT (F)	1/2" NPT (F)
Max flow rate	42L/min (11gal/min)	45L/min (11.9gal/min)	174L/min (46gal/min)	265L/min (70gal/min) (viscosity dependent)	598L/min (158gal/min) (viscosity dependent)
Suction lift	3.6m (12ft) (dry) 9.1m (30ft) (wet)	3.9m (12.8ft) (dry) 6.7m (22ft) (wet)	4.9m (16ft) (dry) 9.4m (31ft) (wet)	4.6m (15ft) (dry) 7.6m (25ft) (wet)	5.2m (17ft) (dry) 9.8m (32ft) (wet)
Max solids handling	1.6mm (0.0625")	1.6mm (0.0625")	3.2mm (0.125")	4.76mm (0.188")	6.4mm (0.25")
Fluid temperature	0°C - 82°C (32°F - 180°F)	*-23°C - +88°C (-9.4°F - 190°F)	*-23°C - +88°C (-9.4°F - 190°F)	*-12°C - +82°C (10°F - 180°F)	*-12°C - +82°C (10°F - 180°F)
Max noise level	86 dB(A)	84 dB(A)	93 dB(A)	77 dB(A)	96 dB(A)
Suitable fluids	*Suitable for oils (new & used), engine coolants RTU (new & used), oily water and diesel				
Wetted Parts	Polypropylene (body & valve seats), Buna N (diaphragms), acetal (check valves)	Aluminium/ Polypropylene (body), aluminium (valve seats), Buna N (diaphragms), acetal (check valves)		Cast aluminium (body), Buna N (valve seats, diaphragms, check valves)	Cast aluminium (body), Buna N (valve seats, diaphragms, check valves)

Service Parts (For DDP13 & DDP19)

- **L-E505BN:** Diaphragm
- **L-E5P BN/A KIT:** Wet End Kit
- **L-E5AV KIT:** Air End Kit
- **L-E5PV KIT:** Pilot Valve Kit
- **L-VTM-3:** Muffler

Service Parts (For DDP25)

- **L-V183BN-1:** Diaphragm
- **L-V1.0 BN/A Kit:** Wet End Kit
- **L-E1P AV KIT:** Air Valve Kit
- **L-VTM-4:** Muffler
- **L-E1P PV Kit:** Pilot Valve Kit

Service Parts (For DDP38)

- **DRV1.25BNKIT:** Wet side rebuild
- **E4AAVKIT:** Air valve kit
- **E4PVKIT:** Pilot Valve kit

Service Parts (For DDP50)

- **L-VTM-5:** Exhaust Muffler
- **V224BN:** Diaphragm Repair Kit
- **V2.0-BN-Kit:** Fluid Repair Kit

Recommended to be used with:



M4WV19
3/4" BSP 4 Way Valve
(Page 90)



M4WV25
1" 4 BSP Way Valve
(Page 90)



M4WV38
1 1/2" BSP 4 Way Valve
(Page 90)

4 WAY EVACUATION VALVES



4 Way Evacuation Valves

4 Way Evacuation Valve is used for the extraction and discharge of fluids which reduces the necessity of multiple valves controlling fluid flow. The fluid can be waste oil, hydraulic, gear and engine oil, ATF or coolants. The valve makes the operation easier for the transfer of fluid by just shifting the lever which reverses the flow of the fluid from filling to discharging the waste oil/fluids or vice versa. This valve requires only one pump for both the operation and is simplified without the hose/pipe connections being altered.

Easy Operation

The 4 Way Evacuation Valve makes operation easy for the transfer of fluid by reducing the necessity for multiple valves.

Dimensions

105mm x 105mm x 90mm
Weight = 1kg (2.2lbs)

Easy Installation

Four pre-drilled mounting holes - M8x1.25 have been provided for convenient installation.



Reverse Flow

Extraction and Discharge of fluids can be controlled by just repositioning the handle to the desired requirement.

Single Pump

One pump is sufficient for both operations (discharge and extraction of fluid) which simplifies the plumbing.

No Flow restriction

There will be no pressure or volume loss during the flow in either direction.

Why choose this product?

The Macnaught 4 Way Evacuation Valves make it easier to transfer fluid by simply shifting the lever to fill or discharge fluids using only one pump.

Applications:

- Transfer Fluids from bulk supply containers to daily operational tanks.
- Extraction and discharge of various types of fluids on lube/service trucks.
- Extraction of fluids from engines set in remote locations- irrigation fields/mining sites

Part Number	M4WV19	M4WV25	M4WV38
Description	3/4" BSP Inlet/Outlet Connections	1" BSP Inlet/Outlet Connections	1 1/2" BSP Inlet/Outlet Connections
Inlet/ Outlet	3/4" BSP	1" BSP	1 1/2" BSP
Max Working Pressure	200psi (14bar)	200psi (14bar)	200psi (14bar)

Recommended to be used with M4WV19:					
Recommended to be used with M4WV25:					
Recommended to be used with M4WV38:					

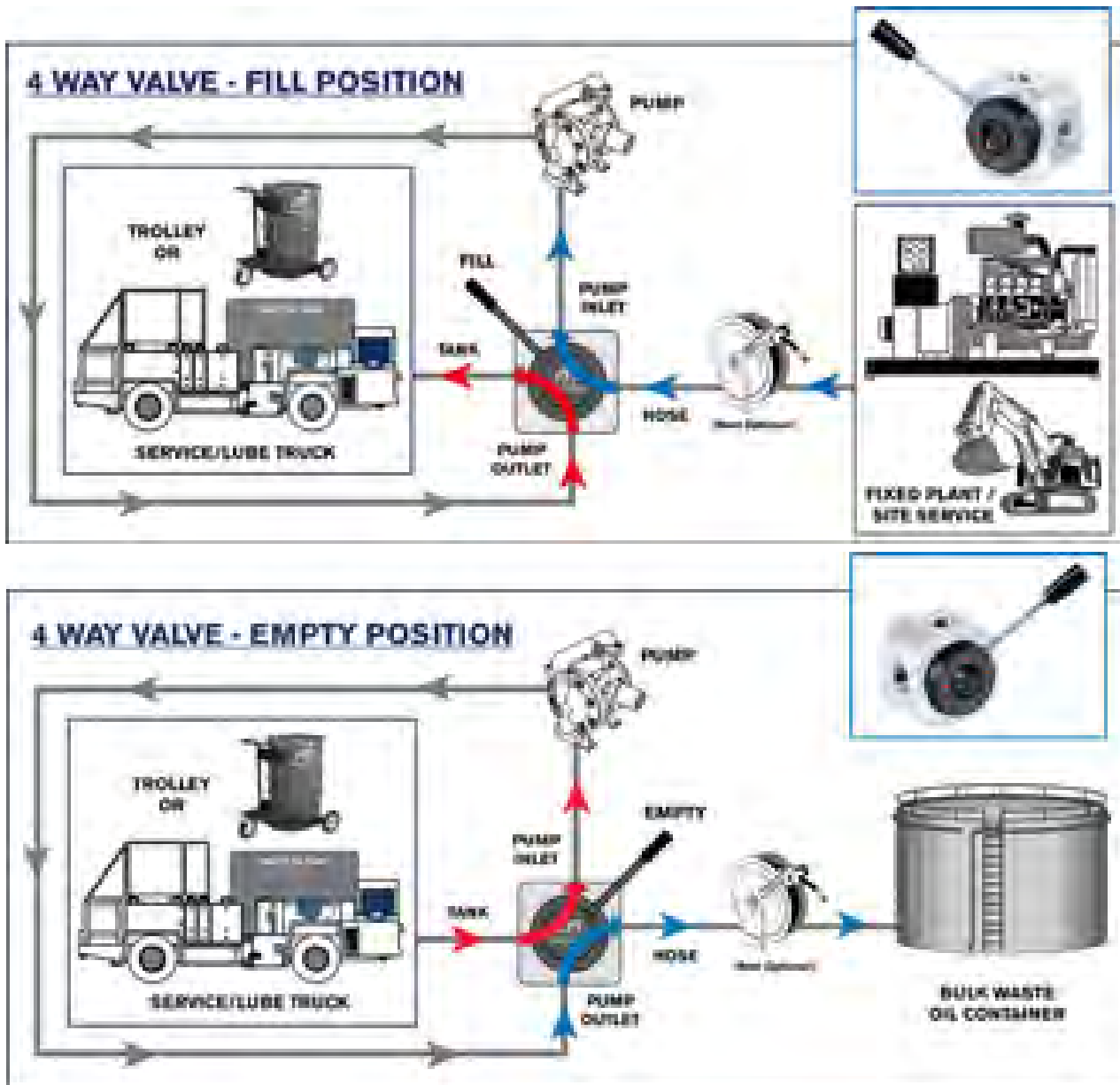

* The suction line of the pump should be as close as possible to the suction point.

4 Way Evacuation Valve Kits

EVACTR-MC Kit includes

- M4WV19 - 3/4" Four way valve
- DDP19 - Double diaphragm pump
- TR205-01 - 205ltr Drum Trolley
- L-FS19 - 3/4" Swivel
- Suction tube assembly
- Camlock fittings
- All the required hoses and fittings

EVACTR-LM Kit includes

- M4WV19 - 3/4" Four way valve
- L-DDP19 - Double diaphragm pump
- TR205-01 - 205ltr Drum Trolley
- L-FS19 - 3/4" Swivel
- Suction tube assembly
- Camlock fittings
- All the required hoses and fittings

MACNAUGHT VERSION EVACTR-MC

LUBEMATE VERSION EVACTR-LM (See page 161)



*205L drum not included

Long delivery hose

Suction tube and bung adaptor assembly

Can lock fittings for quick removal and connection

3/4" double diaphragm pump (heavy duty and reliable)

Swivel caster with wheel lock break for safety while in use

Heavy duty TR205 drum trolley allows easy access as required

FUEL EQUIPMENT SYSTEMS

Poly Diesel Tanks

The Macnaught Poly Tanks are the only portable diesel tanks on the Australian market to not only offer a 15 year warranty on the tank but a full 5 year warranty on the pump unit. Assembled using the highest quality, specially formulated polyethylene to withstand the harshest conditions, they offer lightweight yet sturdy fuel storage solutions. Designed with numerous safety features including auto shut-off nozzles to prevent fuel wastage, an earth strap to prevent the build-up of static electricity when the tank is in use and 3 lock security points. Together, these features provide the operator with peace of mind when refuelling.



Premium Quality 12V Fuel Pump
Automatic Nozzle 12V Electric fuel pump for reliable diesel fuel delivery

Streamline compact design
Ideal for mounting to Ute and service trucks

Heavy duty Polyethylene Tank construction
Lightweight and very strong with 15 years warranty

3 point lockable security
3 point security (lockable lid, nozzle and fuel cap) which ensures peace of mind

Automatic nozzle
Prevent fuel waste or spillage

MDT300L



Baffles included*

Why choose this product?

The poly diesel tanks are designed to withstand the harshest conditions. The lightweight tank with built in safety features and reliable premium quality diesel pump gives the operator peace of mind when refueling is required.

*Baffles included on MDT1000L and MDT1200L models only

Recommended to be used with:



ADTFM Digital Meter (Page 97)

Applications:

Ideal addition to the back of a Service truck, Ute or portable diesel fuel system.

Macnaught 12V Electric Diesel Pump Kit

Extra-long 4m (13ft) hose

Flow rates up to 85LPM



30 minute duty cycle

Lockable lid to prevent fuel theft

Self priming - trouble free operation

12V Electric Diesel Pumps

The Macnaught Poly Tanks come fitted with a 12V diesel pump capable of delivering 40LPM/ 85LPM dependent on model.
(Tank kit and Pump model specified below)



12V ELECTRIC DIESEL PUMP KIT
AUTOMATIC NOZZLE - 40LPM
AFP12A



12V HIGH FLOW ELECTRIC DIESEL PUMP
KIT AUTOMATIC NOZZLE - 85LPM
AHFP85L-12A



Available in the following models

- MDT100L
- MDT200L
- MDT300L
- MDT400L
- MDTN400L
- MDT600L

Available in the following models

- MDT800L
- MDT1000L (baffles included)
- MDT1200L (baffles included)

FUEL EQUIPMENT SYSTEMS

Poly Diesel Tank Kit Range



Why choose this product?

The poly diesel tanks are designed to withstand the harshest conditions. The lightweight tank with built in safety features and reliable premium quality diesel pump gives the operator peace of mind when refueling is required.



Part Number	MDT100L	MDT200L	MDT300L	MDT400L
Description	100L Diesel Tank with 12V Pump Kit - 40L/min	200L Diesel Tank with 12V Pump Kit - 40L/min	300L Diesel Tank with 12V Pump Kit - 40L/min	400L Diesel Tank with 12V Pump Kit - 40L/min
Flow rate	Up to 40L/min (11gal/min)	Up to 40L/min (11gal/min)	Up to 40L/min (11gal/min)	Up to 40L/min (11gal/min)
Electric pump kit	12V Electric diesel pump kit			
Capacity	100L (26gal)	200L (53gal)	300L (79gal)	400L (106gal)
Nozzle	Automatic	Automatic	Automatic	Automatic
3 point security (lockable lid, nozzle and fill cap)	✓	✓	✓	✓
Bucket Strainer	✓	✓	✓	✓
Built-in suction hose	✓	✓	✓	✓
Delivery hose	19mm (3/4") x 4m (13ft)	19mm (3/4") x 4m (13ft)	19mm (3/4") x 4m (13ft)	19mm (3/4") x 4m (13ft)
Earthing cable	✓	✓	✓	✓
Moulded carry handles	✓	✓	✓	✓
Dimensions	800L x 680W x 465H	800L x 680W x 710H	1290L x 600W x 770H	1150L x 820W x 780H
Suitable Fluids	Suitable for diesel			
Warranty ¹	15 years (tank) 5 years (pump)	15 years (tank) 5 years (pump)	15 years (tank) 5 years (pump)	15 years (tank) 5 years (pump)

Features & Benefits

- 12V Electric pump kit
- Built-in suction hose
- Automatic nozzle
- 3 point security (lockable lid, nozzle and fill cap)
- Bucket strainer
- Earthing cable
- Moulded carry handles

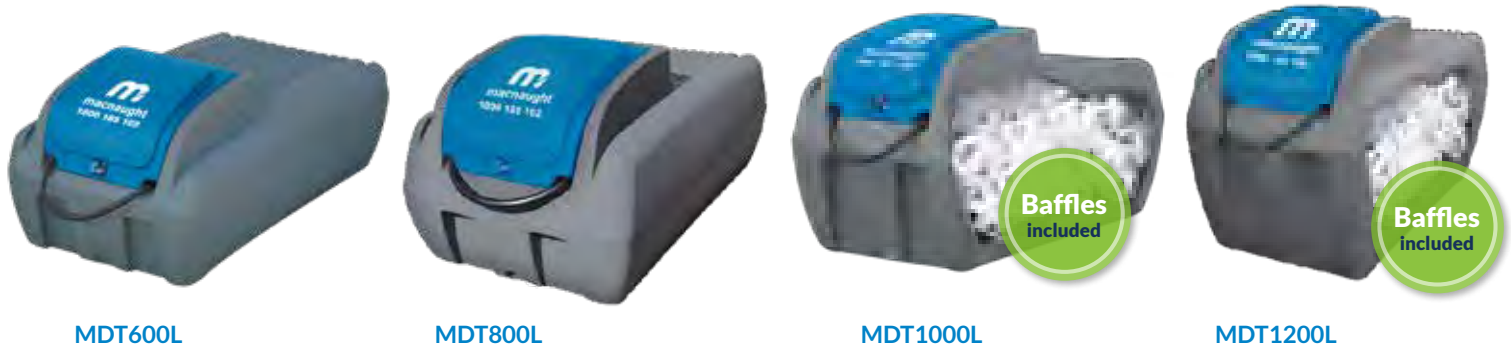

MDTN400L	MDT600L	MDT800L	MDT1000L	MDT1200L
400L Narrow Diesel Tank with 12V Pump Kit - 40L/min	600L Diesel Tank with 12V Pump Kit - 40L/min	800L Diesel Tank with High Flow 12V Pump - 85L/min	1000L Diesel Tank with High Flow 12V Pump - 85L/min	1200L Diesel Tank with High Flow 12V Pump - 85L/min
Up to 40L/min (11gal/min)	Up to 40L/min (11gal/min)	Up to 85L/min (22.5gal/min)	Up to 85L/min (22.5gal/min)	Up to 85L/min (22.5gal/min)
12V Electric diesel pump kit				
400L (106gal)	600L (158gal)	800L (211gal)	1000L (264gal)	1200L (317gal)
Automatic	Automatic	Automatic	Automatic	Automatic
✓	✓	✓	✓	✓
✓	✓	✓	✓	✓
✓	✓	✓	✓	✓
19mm (3/4") x 4m (13ft)	19mm (3/4") x 4m (13ft)	25mm (1") x 4m (13ft)	25mm (1") x 4m (13ft)	25mm (1") x 4m (13ft)
✓	✓	✓	✓	✓
✓	✓	✓	✓	✓
1290L x 600W x 965H	1700L x 880W x 740H	1700L x 1000W x 860H	1700L x 1000W x 1025H	1700L x 1000W x 1190H
Suitable for diesel				
15 years (tank) 5 years (pump)	15 years (tank) 5 years (pump)	15 years (tank) 5 years (pump)	15 years (tank) 5 years (pump)	15 years (tank) 5 years (pump)

Note¹: 15 years warranty on tanks, 5 years warranty on pumps. Subject to Macnaught warranty terms and conditions, see www.macnaught.com.au/warranty.

MECHANICAL FUEL METERS

In-line fuel meters

These positive displacement fuel meters are ideal for use with electric diesel pumps, remote field and in-line use. Macnaught Mechanical Fuel Meters provide reliable and accurate measurement of liquid without the need for power or batteries.



Gravity Fed systems
Low pressure drop for use with gravity fed systems

Rotatable Face
Register Cap is rotatable for easy display



DM100-01

Solid Body
Robust aluminium meter body

Meter Technology
Oval Gear technology with mechanical register for high accuracy

Calibration
No field calibration needed

Rotatable Face
Register can be rotated up to 180° for easy display

Nutating Disc

Calibration screw
For easy field calibration



AMFM



Why choose this product?

Meter oval gear provides accurate measurement.

Part Number	DM100-01	AMFM
Description	Mechanical Fuel Meter	Mechanical Diesel Meter
Flow range	3 - 80L/min (0.8 - 21gal/min)	20 - 120L/min (5 - 31gal/min)
Meter / register	Oval gear / Mechanical	Mechanical
Accuracy (flow rate)	+/- 1%	+/- 1% of reading when field calibrated
Features	Low pressure drop makes this meter suitable for gravity fed systems register cap is rotatable for easy display mesh strainer included	4-digit resettable total 8-digit non-resettable total Register can be rotated (180 degrees)
Inlet port	1" BSP (F)	1" BSP (F)
Outlet port	1" BSP (F)	1" BSP (F)
Compatible fluids	Diesel, kerosene, light oils and petrol	Suitable for diesel, kerosene and light oils
Max working pressure	50psi (3.5bar)	50psi (3.5bar)
Min/Max working Temp	-5° to 80°C (23°F-176°F)	"-26°C (-15 °F) to +66°C (150°F)
Warranty	10 years	5 years

Recommended to be used with:

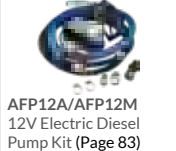
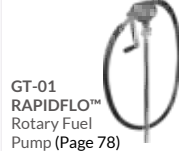

Service Parts for DM100-01

- DM100-1K Seal Kit

DIGITAL FUEL METERS

In-line fuel meters

The Macnaught Digital Turbine meters are compact, lightweight and accurate and are ideal for use on gravity or in-line applications, or with an automatic fuel nozzle. The meters have a field calibration accuracy of +/- 0.5%. The electronic display can be rotated 180°C and contains a built in computer with many useful additional features listed below.



ADTFM

Solid Body
Robust aluminium meter body

Meter Technology
Oval Gear technology with mechanical register for high accuracy

Rotatable Face
Register can be rotated up to 180° for easy display

Field calibration capability



ADTUM

Why choose this product?

Turbine meter provides reliable accurate measurement

Part Number	ADTFM	ADTUM
Description	Digital Diesel Meter	Digital Urea/DEF Meter
Flow range	10 - 150L/min (2.6 - 40gal/min)	10 - 150L/min (2.6 - 40gal/min)
Meter/ register	Electronic	Electronic
Accuracy	+/-0.5%	+/-0.5%
Features	6-digit reset total 6-digit non-reset total	6-digit reset total 6-digit non-reset total
Max working pressure	50psi (3.5bar)	50psi (3.5bar)
Inlet port	1" BSP	1" BSP
Outlet port	1" BSP	1" BSP
Compatible fluids	Suitable for diesel, kerosene and coolants	Suitable for UREA/DEF and water

Recommended to be used with:

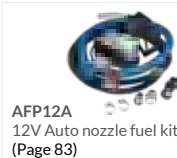

INDUSTRIAL FLOW METERS

Macnaught Industrial Flow Meters

As the global oval gear flow meter technology leader with over 50 years experience, Macnaught offers two comprehensive product ranges that solve a number of challenging flow conditions. These Australian manufactured meters are all tested and are supplied with a calibration certificate.

The MX-SERIES is the latest innovation featuring:

- High precision billet constructions for enhanced material integrity & process reliability
- Programmable digital display & pulse output options
- Unique bayonet assembly for added versatility & flexibility



The M-SERIES is Macnaught's original range featuring:

- Established design & cast construction for proven performance
- Mechanical & pulse output options

Advantages

- Models available to suit a wide range of fluids
- Oval gear technology delivers high accuracy +/- 0.5% & repeatability of +/- 0.03%
- Flow ranges from 0.5 L/min to 1200 L/min in sizes 1/4" to 4"
- Suitable for viscous fluids
- Low cost of ownership
- Industry leading supply turnaround
- Accuracy unaffected by changes in viscosity
- Minimal maintenance required
- Ease of installation – no flow conditioning required
- Compact overall lay length means no support issues & superior design capabilities over alternative flow devices
- Exceptional turn down ratio

Applications

Flow meters are available to suit all industry types and most applications. The Macnaught industrial range of meters are specifically manufactured to suit your specific individual requirements.

	MX-Series	M-Series	
Materials of construction	Billet construction, Stainless Steel, Aluminium	Cast construction, Stainless Steel, Aluminium, PPS	
Process Connection	BSP, NPT, ANSI Class 150, JIS, 10K, DIN PN16		
Output	Standard Pulse, Intrinsically Safe Pulse, High Temp. Pulse 4 - 20mA output	Standard Pulse, Standard Mechanical Register, Heavy Duty Mechanical Register	

	Flow Ranges		Turndown Ratio
1/4"	0.13 - 26 GPH	0.5 - 100 L/hr	200 : 1
1/4"	4 - 132 GPH	15 - 500 L/hr	33 : 1
1/2"	0.5 - 8 GPM	2 - 30 L/min	15 : 1
3/4"	0.8 - 21 GPM	3 - 80 L/min	26 : 1
1"	1.6 - 32 GPM	6 - 120 L/min	20 : 1
1 1/2"	2.6 - 66 GPM	10 - 250 L/min	25 : 1
2"	4 - 130 GPM	15 - 500 L/min	33 : 1
3"	5 - 194 GPM	20 - 733 L/min	36 : 1
4"	31.7 - 317 GPM	120 - 1200 L/min	10 : 1

For more information, please contact your local Macnaught Representative or contact us at flowmeters@macnaught.com
www.macnaughtflowmeasurement.com.au

High precision instruments ideal for use in the following applications:

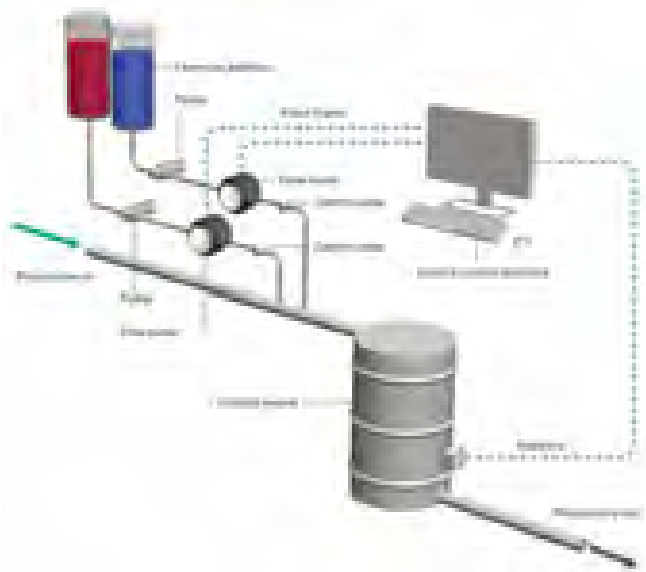

BATCHING

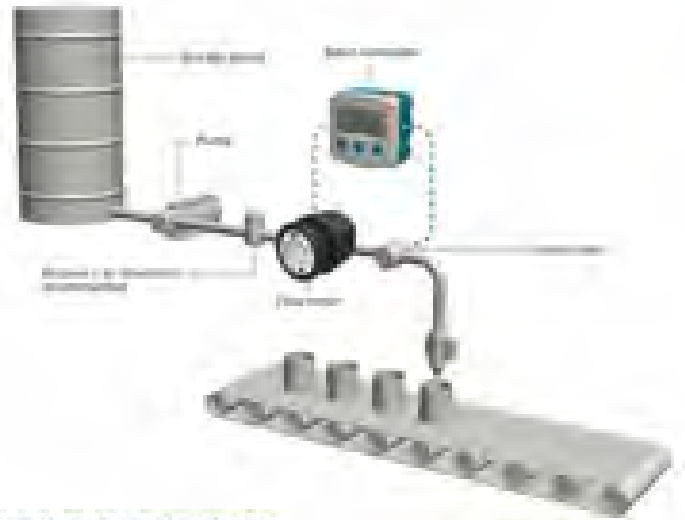

FUEL CONSUMPTION

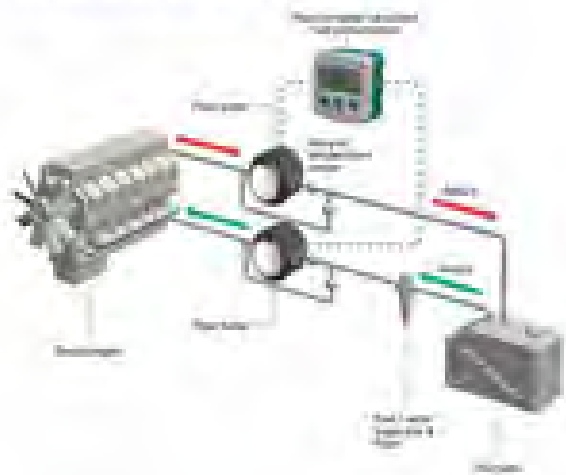

BULK FUEL TRANSFER

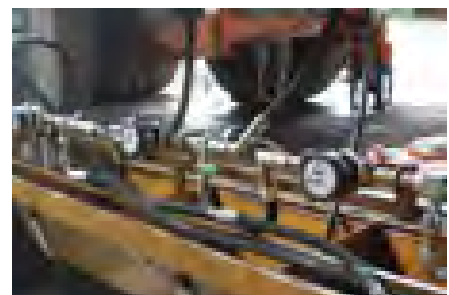
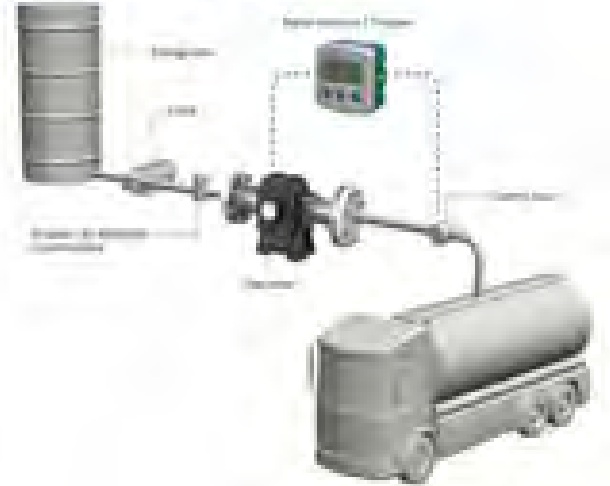

FUEL ACCESSORIES

12
MONTH
MACNAUGHT
WARRANTY*



FUEL FILTER KIT
HA-01
Fuel filter kit to suit LITRESTROKE™ pump. Includes 10µm filter and fittings to connect to pump.
Max pressure: 150psi



FUEL FILTER ASSEMBLY
HA1S-01
10µm fuel filter – 1" BSP. Uses 10µm replacement filter elements.
Max pressure: 150psi



FUEL FILTER ASSEMBLY
HA1SS80
80 MESH – 1" BSP (F) ports. Uses 80MESH stainless steel strainer for more contaminated applications.
Max pressure: 150psi



FUEL FILTER KIT
VA-01
Fuel filter kit to suit RAPIDFLO™ RVP and GT pumps. Includes 10µm filter and fittings to connect to pump.
Max pressure: 150psi.



STAINLESS STEEL STRAINER
HASS40S
40 MESH replacement element
HASS80S
80 MESH replacement element



REPLACEMENT FUEL FILTER
HA7S
Replacement 10µm fuel filter element to fit GB, HA, VA and HA1S filters.



BUNG ADAPTOR - 2" BSP
AC26
Blue bung adaptor 2" BSP (F) - 2" (M) Mouser
AC27
Orange bung adaptor 2" BSP (F) - 2" (M) Tri-Sure
AC28
Yellow bung adaptor 2" BSP (F) - Din 61 (F)

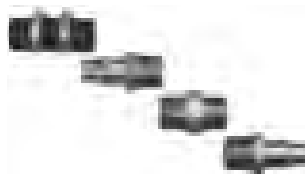

FITTINGS KIT FOR HP-01
DH-01
Fittings kit for connecting DM100/150 meters to LITRESTROKE™ pumps

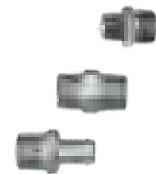

FITTINGS KIT FOR GT-01
DV-01
Fittings kit for connecting DM100/150 meters to RAPIDFLO™ pumps



NOZZLE FOR DIESEL/ULP FUELS
HNU
Nozzle for diesel/ULP fuels. For use with HP or GT pumps



TELESCOPIC SUCTION TUBE
TB25S
Telescopic suction tube: 1" BSP (M), length 615 - 1035mm (24" - 40"). Suitable for oil and diesel.



TELESCOPIC SUCTION TUBE WITH STRAINER
ATS205
Designed for use with the Macnaught range of electric fuel pumps when used to pump out of 205L containers. The 2" sliding bung adaptor has a 3/4" BSP (M) thread connection. Closed length is 590mm and open length is 1030mm.

GREASE HOSE REELS

Grease Reels - Single Pedestal Models

The Macnaught range of heavy duty Reels are designed and manufactured using the highest quality materials and finish that guarantee reliability and durability. The reels are ideal for use in wide range of applications and can be fitted in a variety of positions such as Wall, floor, tank, truck or overhead.



Adjustable guide arms and variable roller guide direction for versatility

Fitted with heavy duty hose

Fully serviceable



Heavy duty powder coated steel construction

Heavy duty steel spring enclosure for safety and reliability

MGS0615-01

Part Number	MGS0615-01
Description	Single Pedestal Grease Reel 6mm x 15m
Reel Type	Single Pedestal
Application	Grease
Hose Size (ID)	6mm (1/4")
Working Pressure	34,500kPa (5000 psi)
Hose Material	Steel Wire Braided Rubber
Reel Inlet	1/4" BSP(F)
Hose Outlet	1/4" BSP(M)
Hose Length	15m (50 ft)

Applications:

All models are ideal for use in all workshop applications. The range of twin pedestal reels are also suitable for off road service vehicle applications.

Service Parts

- See pages [241](#) and [242](#)

Recommended to be used with:

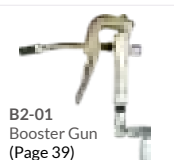

GREASE HOSE REELS

Grease Reels - Twin Pedestal Models

The Macnaught range of heavy duty Reels are designed and manufactured using the highest quality materials and finish that guarantee reliability and durability. The reels are ideal for use in wide range of applications and can be fitted in a variety of positions such as Wall, floor, tank, truck or overhead.



Adjustable roller guide direction for versatility

Twin pedestal for strength and stability

Fully serviceable

Heavy duty powder coated steel construction

Heavy duty steel spring Enclosure for safety and reliability

MGTP0615-01, MGTP0915-01

Part Number	MGTP0615-01	MGTP0915-01
Description	Twin Pedestal Grease Reel 6mm x 15m	Twin Pedestal Grease Reel 10mm x 15m
Reel Type	Twin Pedestal	Twin Pedestal
Application	Grease	Grease
Hose Size (ID)	6mm (1/4")	10mm (3/8")
Working Pressure	34, 500kPa (5000 psi)	34, 500kPa (5000 psi)
Hose Material	Steel Wire Braided Rubber	Steel Wire Braided Rubber
Reel Inlet	1/4" BSP(F)	3/8" BSP(F)
Hose Outlet	1/4" BSP(M)	3/8" BSP(M)
Hose Length	15m (50 ft)	15m (50 ft)

Applications:

All models are Ideal for use in all workshop applications. The range of twin pedestal reels are also suitable for off road service vehicle applications.

Service Parts

- See pages [241](#) and [242](#)

Recommended to be used with:

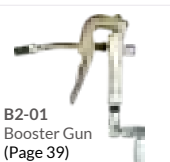

OIL/DIESEL HOSE REELS

Oil/Diesel Reels - Single and Twin Pedestal Models

The Macnaught range of heavy duty Reels are designed and manufactured using the highest quality materials and finish that guarantee reliability and durability. The reels are ideal for use in wide range of applications and can be fitted in a variety of positions such as Wall, floor, tank, truck or overhead..



MOS1220-01

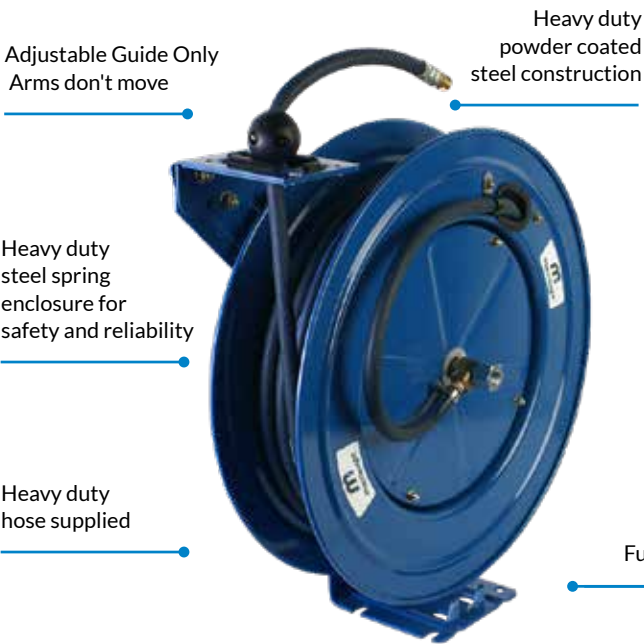

MOTP1220-01, MOTP1920-01, MDTP2510-01, MDTP2520-01

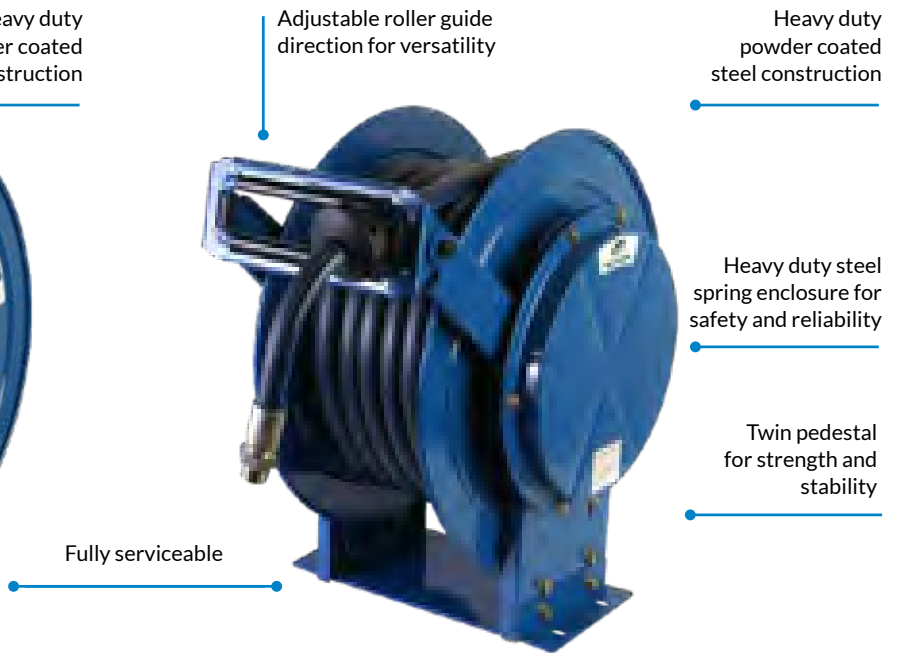

Part Number	MOS1220-01	MOTP1215-01	MOTP1220-01	MOTP1920-01	MDTP2510-01	MDTP2520-01
Description	Oil Reel 12mm x 20m	Oil Reel 12mm x 15m	Oil Reel 12mm x 20m	Oil Reel 19mm x 20m	Diesel/Oil Reel 25mm x 10m	Diesel/Oil Reel 25mm x 20m
Reel Type	Single Pedestal	Twin Pedestal (Low roller)	Twin Pedestal	Twin Pedestal	Twin Pedestal	Twin Pedestal
Application	Oil	Oil	Oil	Diesel/Oil	Diesel/Oil	Diesel/Oil
Hose Size (ID)	12mm (1/2")	12mm (1/2")	12mm (1/2")	19mm (3/4")	25mm (1")	25mm (1")
Working Pressure	13,800kPa (2,000 psi)	13,800kPa (2,000 psi)	13,800kPa (2,000 psi)	8,600kPa (1,250psi)	3,500kPa (500psi)	3,500kPa (500psi)
Hose Material	Steel Wire Braided Rubber	Steel Wire Braided Rubber	Steel Wire Braided Rubber	Steel Wire Braided Rubber	Steel Wire Braided Rubber	Steel Wire Braided Rubber
Reel Inlet	1/2" BSP(F)	1/2" BSP(F)	1/2" BSP(F)	3/4" BSP(F)	1" BSP(F)	1" BSP(F)
Hose Outlet	1/2" BSP(M)	1/2" BSP(M)	1/2" BSP(M)	3/4" BSP(M)	1" BSP(M)	1" BSP(M)
Hose Length	20m (65ft)	15m (50 ft)	20m (65ft)	20m (65ft)	10m (33ft)	20m (65ft)

Applications:

All models are Ideal for use in all workshop applications. The range of twin pedestal reels are also suitable for off road service vehicle applications.

Service Parts

- See pages [241](#) and [242](#)

Recommended to be used with:

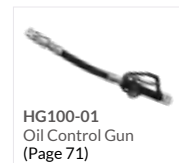

AIR/WATER HOSE REELS



Air/Water Reels - Single and Twin Pedestal Models

The Macnaught heavy duty Reels are designed and manufactured using the highest quality materials and finish that guarantee reliability and durability. The reels are ideal for use in wide range of applications and can be fitted in a variety of positions such as Wall, floor, tank, truck or overhead.

MAS1020-01, MAS1220-01

Adjustable roller guides for directional versatility

Heavy duty steel spring enclosure for safety and reliability

Heavy duty hose supplied

Heavy duty powder coated steel construction

MATP1220-01, MATP1920-01

Adjustable roller guides for directional versatility

Heavy duty powder coated steel construction

Heavy duty steel spring enclosure for safety and reliability

Twin pedestal for strength and stability

Fully serviceable

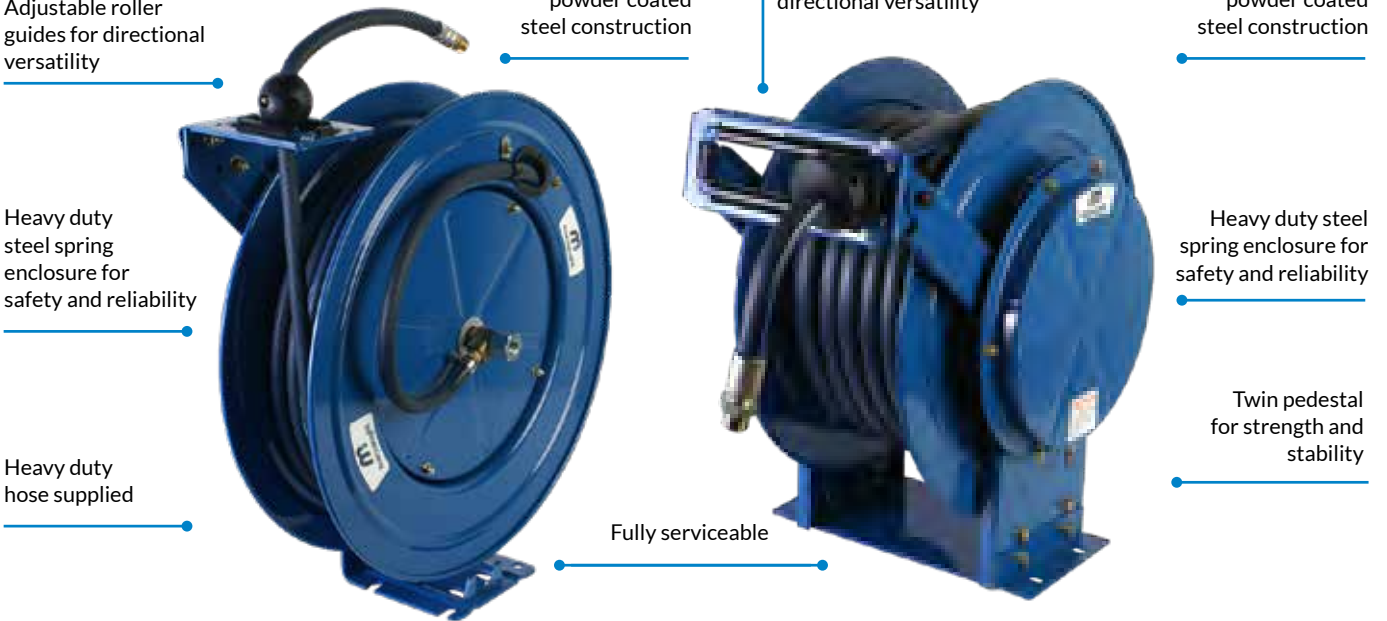

Part Number	MAS1020-01	MAS1220-01	MATP1220-01	MATP1920-01
Description	Air/Water Single Pedestal Reel 10mm x 20m	Air/Water Single Pedestal Reel 12mm x 20m	Air/Water Twin Pedestal Reel 12mm x 20m	Air/Water Twin Pedestal Reel 19mm x 20m
Reel Type	Single Pedestal	Single Pedestal	Twin Pedestal	Twin Pedestal
Application	Air/Water	Air/Water	Air/Water	Air/Water
Hose Size (ID)	10mm (3/8")	12mm (1/2")	12mm (1/2")	19mm (3/4")
Working Pressure	2, 100kPa (300psi)	2, 100kPa (300psi)	2, 100kPa (300psi)	2, 100kPa (300psi)
Hose Material	Synthetic Rubber	Synthetic Rubber	Synthetic Rubber	Synthetic Rubber
Reel Inlet	3/8" BSP(F)	1/2" BSP(F)	1/2" BSP(F)	3/4" BSP(F)
Hose Outlet	3/8" BSP(M)	1/2" BSP(M)	1/2" BSP(M)	3/4" BSP(M)
Hose Length	20m (65ft)	20m (65ft)	20m (65ft)	20m (65ft)

Applications:

All models are Ideal for use in all workshop applications. The range of twin pedestal reels are also suitable for off road service vehicle applications.

Service Parts

- See pages 241 and 242

Recommended to be used with:



BARE REELS

Bare Reels - Single and Twin Pedestal Models

The Macnaught heavy duty Reels are designed and manufactured using the highest quality materials and finish that guarantee reliability and durability. The reels are ideal for use in wide range of applications and can be fitted in a variety of positions such as Wall, floor, tank, truck or overhead.



MRS1320N-01

Adjustable roller guides for directional versatility

Heavy duty powder coated steel construction

Heavy duty steel spring enclosure for safety and reliability

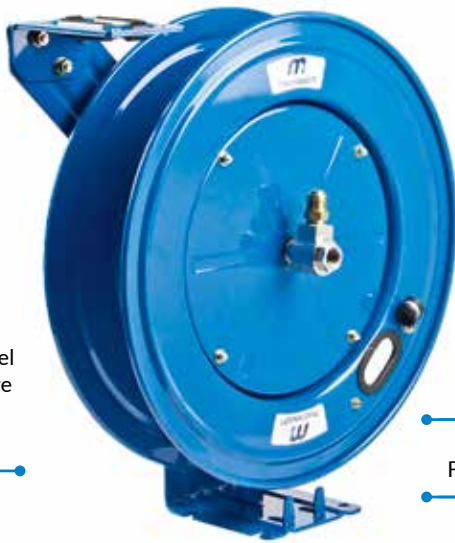

MRTP1320N-01, MRTP2520N-01

Adjustable roller guides for directional versatility

Heavy duty powder coated steel construction

Heavy duty steel spring enclosure for safety and reliability

Twin pedestal for strength and stability



Bare Reel

Fully serviceable

Part Number	MRS1320N-01	MRTP1320N-01	MRTP2520N-01
Description	Bare Single Pedestal Reel 12mm x 20m	Bare Twin Pedestal Reel 12mm x 20m	Bare Twin Pedestal Reel 25mm x 20m
Reel Type	Single Pedestal	Twin Pedestal	Twin Pedestal
Application	Air/Water/Oil	Air/Water/Oil	Air/Water/Oil
Hose Size (ID)	12mm (1/2")	12mm (1/2")	25mm (1")
Working Pressure	6900kPa (1000psi)	6900kPa (1000psi)	6900kPa (1000psi)
Reel Inlet	1/2" BSP(F)	1/2" BSP(F)	1" BSP(F)
Reel Outlet	1/2" BSP(F)	1/2" BSP(F)	1" BSP(F)
Hose Length Capacity	20m (65ft)	20m (65ft)	20m (65ft)

Applications:

All models are ideal for use in all workshop applications. The range of twin pedestal reels are also suitable for off road service vehicle applications.

Service Parts

- See pages 241 and 242

Recommended to be used with:





RETRACTA[®]
BY RETRACTA



RETRACTA IN THE INDUSTRY

Retracta is the benchmark in industrial strength retractable hose reels. Over the decades the original Retracta poly reel has built an enviable reputation worldwide for performance and reliability. Through this, and with a long history of innovation and design, Macnaught has now developed an exciting new range of Retracta reels specifically designed and engineered for the most demanding industrial applications and environments.

Innovation has always been at the centre of the Macnaught success story and it's the platform for developing our expanded Retracta range.

At Macnaught we call it "Innovation by Design".

Because we know that innovation is the only way to stay ahead. This is what sets us apart from our competitors and gives our customers confidence backed by up to 10 year* mechanical warranty and guaranteed parts availability.

* Note: Subject to Macnaught warranty terms and conditions see macnaught.com/warranty or see page 267.

AGRICULTURE

TRANSPORT

AUTOMOTIVE

CIVIL

MINING

Retracta R3 Series

Innovation by Design.

For 70 years, continual innovation has been the key to Macnaught's success. So, it's no surprise that through Macnaught's principle of "Innovation by Design" that a new and exciting range of Retracta reels has been developed.

For decades now the original Retracta poly reel has been developed and has built an enviable worldwide reputation for performance, reliability and safety. With this new suite of products, Retracta continues to set the benchmark for industrial strength, retractable hose reels.



This industry leading range now incorporates multiple reel constructions, specifically designed and engineered for the most demanding industrial applications and environments.

RetractaFLEX

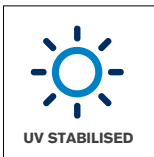

Adding to the stable of truly innovative products is the new range of RetractaFLEX hoses, available on a selection of our R3 Series reels. Featuring an innovative hybrid polymer that allows for the ultimate in flexibility and kink resistance under pressure.

The Retracta family has also expanded to include the sleek E-Series range of enclosed reels for automotive workshop gantries; the Hybrid H-Series steel framed twin pedestal reels which feature a robust ABS drum; and in another world first, the heavy duty F-Series powder coated steel pedestal and cradle frame reels, which include a unique series of integrated 'Metered' models.



RACR®



The iconic Retracta poly reels have been re-imagined and updated; and in a world first, the new Retracta R3 range includes an adjustable control return system. The patented RACR® 'Retracta Adjustable Control Return' system is supplied on all R3-P+ models. The RACR® system offers true control by allowing the user to set the speed of return to suit their individual requirements.

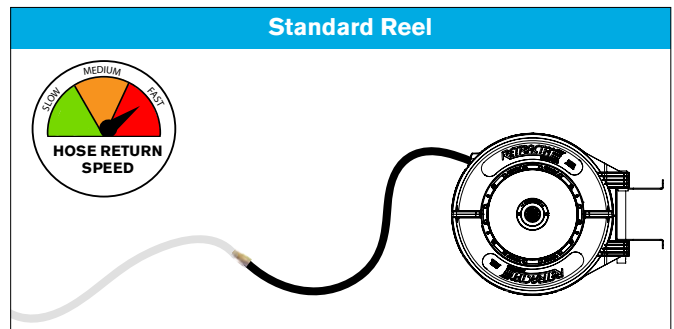
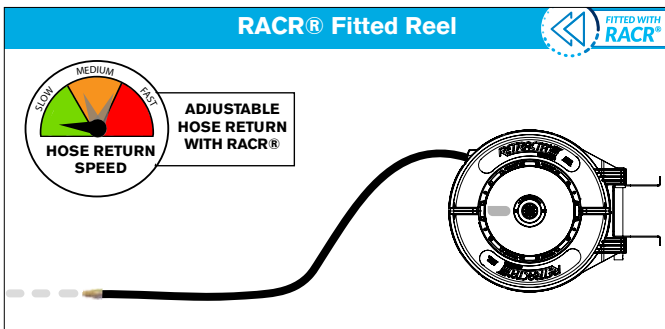

The RACR® reduces the hose speed up to 85% depending on user preference. The slower the hose speed, the safer the overall work environment - as the return speed avoids damages caused by the hose whip.

Look for the  when choosing your reel.

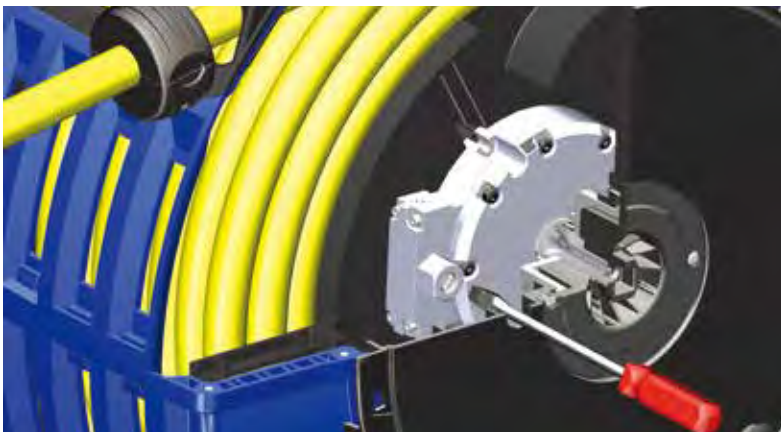

RACR benefits:

- Adjustable hose return speed
- Up to 85% speed reduction
- Eliminate hose whip hazard
- Essential safety for personnel and equipment

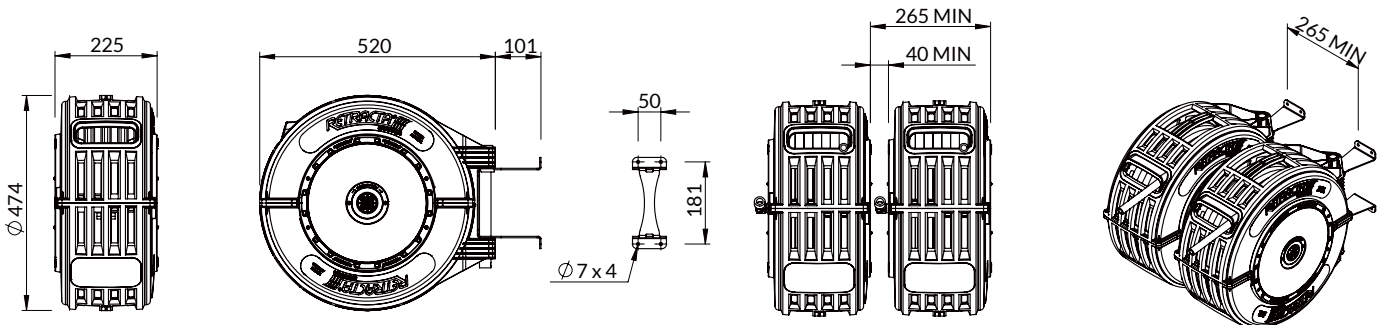

Retracta R3 RetractaFLEX Series

RetractaFLEX PREMIUM AIR & WATER HOSE REEL

Tangled hose lines will be a problem of the past. The NEW RetractaFLEX features an innovative hybrid polymer that allows for the ultimate in flexibility and kink resistance under pressure. Fitted with a bend restrictor at the hose end, the UV stabilised, abrasion-resistant outer layer provides maximum durability.

10
YEARS
MACNAUGHT
WARRANTY*

Great flexibility within temperature range

Kink-free under pressure

HI-VIS fluorescent colours for workplace safety

Memory free hose lays flat on the floor



Light weight and easy to handle

Unique patented RACR (on selected models)

Bend restrictor included*

Why choose this product?

The new RetractaFLEX hose reel comes standard with an innovative hybrid polymer hose allowing for ultimate flexibility and kink resistance under pressure.

Features & Benefits

- Innovative hybrid polymer hose – Ultimate flexibility
- High visibility Yellow, Orange colour hoses for visual identification & safety (Green for garden)
- Upgraded main spring made with TRC – Texture Rolled Carbon
- Safe tensioning mechanism
- High wear resistance mouth with ProGlide
- Fully serviceable
- RACR – on selected models



Applications:

Suitable for use across all industries

Service Parts:

- See page 240 for service kits and parts



Standard		RY315B-01	RY320B-01	RO320B-01	RY420B-01	RO420B-01
RACR		X	RYC320B-01	ROC320B-01	RYC420B-01	ROC420B-01
Case Colour		Blue	Blue	Blue	Blue	Blue
Hose Size (ID)		10mm (3/8")	10mm (3/8")	10mm (3/8")	12mm (1/2")	12mm (1/2")
Hose Length		15m	20m	20m	20m	20m
Hose Color		Yellow	Yellow	Orange	Yellow	Orange
Hose Material		RetractaFLEX Hybrid Polymer				
Working Pressure		300 psi	300 psi	300 psi	300 psi	300 psi
Max Temperature		60°C (140°F)	60°C (140°F)	60°C (140°F)	60°C (140°F)	60°C (140°F)
Reel Inlet		3/8" BSP (F)	3/8" BSP (F)	3/8" BSP (F)	3/8" BSP (F)	3/8" BSP (F)
Hose Outlet		1/4" BSP (M)	1/4" BSP (M)	1/4" BSP (M)	3/8" BSP (M)	3/8" BSP (M)
Other Available Colour:	Standard	X	RY320D-01	RO320D-01	RY420D-01	RO420D-01
	RACR	X	RYC320D-01	ROC320D-01	RYC420D-01	ROC420D-01
	Colour	Blue	Dark Grey	Dark Grey	Dark Grey	Dark Grey

Standard		DR418G-03	DR418P-03
RACR®		DRC418G-03	DRC418P-03
Case Colour		Green	Beige
Hose Size (ID)		12mm (1/2")	12mm (1/2")
Hose Length		18m	18m
Hose Color		Green	Green
Hose Material		RetractaFLEX Hybrid Polymer	
Working Pressure		150 psi	150 psi
Max Temperature		60°C (140°F)	
Reel Inlet		Hose & Tap Connector	
Hose Outlet		Hose Connector	Hose Connector



Retracta R3 Series

COMPRESSED AIR - R3 PREMIUM

10
YEARS
MACNAUGHT
WARRANTY*

The Retracta R3 Premium series is the most robust and reliable hose & reel combination on the market. The highly durable Premium Reinforced PVC hose and industrial strength poly reel gives complete confidence in any demanding industrial compressed air application. The R3 Premium can be upgraded with the RACR system offering true control by allowing the user to set the speed of return to suit their individual requirements.

Unique patented RACR
(on selected models)

Working pressure
275psi

Flexible & abrasive
resistant hose cover

Available in
15m and 20m variants



Available in
3/8" (10mm) and
1/2" (12mm) hose sizes

Premium Reinforced
PVC hose

Fully Serviceable

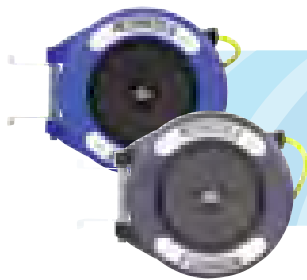

Also available
in Blue and
Dark Grey
cases

Why choose this product?

The robust Retracta R3 - AR series reels for compressed air all carry the Premium Reinforced PVC hose for maximum durability and high pressure rating.

Applications:

Suitable for use across all industries

Features & Benefits

- Highly durable Premium Reinforced PVC hose
- Upgraded main spring made with TRC - Texture Rolled Carbon
- Safe tensioning mechanism
- High wear resistance mouth with ProGlide
- Fully serviceable
- RACR® - on selected models

Service Parts:

- See page 240 for service kits and parts

COMPRESSED AIR

10
YEARS
MACNAUGHT
WARRANTY*



Standard		AR320R-01		AR415R-01		AR420R-01	
RACR		ARC320R-01		ARC415R-01		ARC420R-01	
Case Colour		Red		Red		Red	
Hose Size (ID)		10mm (3/8")		12mm (1/2")		12mm (1/2")	
Hose Length		20m		15m		20m	
Hose Material		Premium Reinforced PVC		Premium Reinforced PVC		Premium Reinforced PVC	
Working Pressure		275 psi		275 psi		275 psi	
Max Temperature		60°C (140°F)		60°C (140°F)		60°C (140°F)	
Reel Inlet		3/8" BSP (F)		3/8" BSP (F)		3/8" BSP (F)	
Hose Outlet		1/4" BSP (M)		3/8" BSP (M)		3/8" BSP (M)	
Other Available Colour:	Standard	AR320B-01	AR320D-01	AR415B-01	AR415D-01	AR420B-01	AR420D-01
	RACR	ARC320B-01	ARC320D-01	ARC415B-01	ARC415D-01	ARC420B-01	ARC420D-01
	Colour	Blue	Dark Grey	Blue	Dark Grey	Blue	Dark Grey

Recommended to be used with:



BB200 R3 Bench Mount Bracket

Retracta R3 Series

COMPRESSED AIR/WATER - R3 STANDARD

10
YEARS
MACNAUGHT
WARRANTY*

The Retracta R3 – Standard AW reel is the most common hose combination in workshops. With air and water compatibility, the AW is encased in the industrial strength poly reel and is ideal for most entry-level conditions.



Working pressure
250psi

Reinforced PVC hose

Available in
15m and 20m variants

Available in
3/8" (10mm) and 1/2"
(12mm) hose sizes

Fully Serviceable

Why choose this product?

The robust Retracta R3 - AW series reels have the ability to carry both compressed air & water.

Features & Benefits

- Highly durable Premium Reinforced PVC hose
- Upgraded main spring made with TRC - Texture Rolled Carbon
- Safe tensioning mechanism
- High wear resistance mouth with ProGlide
- Fully serviceable

Applications:

Suitable for use across all industries

Service Parts:

- See page [240](#) for service kits and parts

COMPRESSED AIR/WATER

10
YEARS
MACNAUGHT
WARRANTY*



Standard	AW315B-01	AW320B-01	AW415B-01	AW420B-01
Case Colour	Blue	Blue	Blue	Blue
Hose Size (ID)	10mm (3/8")	10mm (3/8")	12mm (1/2")	12mm (1/2")
Hose Length	15m	20m	15m	20m
Hose Material	Reinforced PVC	Reinforced PVC	Reinforced PVC	Reinforced PVC
Working Pressure	250 psi	250 psi	250 psi	250 psi
Max Temperature	60°C (140°F)	60°C (140°F)	60°C (140°F)	60°C (140°F)
Reel Inlet	3/8" BSP (F)	3/8" BSP (F)	3/8" BSP (F)	3/8" BSP (F)
Hose Outlet	1/4" BSP (M)	1/4" BSP (M)	3/8" BSP (M)	3/8" BSP (M)

Recommended to be used with:



BB200 R3 Bench
Mount Bracket

Retracta R3 Series

WATER - HOT WASH



The Retracta R3 – Hot Wash Reel is ideal for applications requiring high temperature water and pressure for cleaning or preparation.

Unique patented RACR
(on selected models)

Working pressure
290psi at 20°C
100psi at 80°C

Available in
15m and 20m variants



High Temperature
resistant PVC hose
rated to 85°C

1/2" (12mm) ID hose

Easy to clean hose cover

Why choose this product?

The Retracta R3 Hot Wash reel is extremely reliable for hot water applications up to 85°C and 290psi. Ideal for use in food manufacturing and preparation, bars, clubs and service centres.

Features & Benefits

- Hose applicable for use with hot water up to temperatures of 85°C
- High temp resistant PVC with pressure rating to 290psi at 20°C
- Fully serviceable
- RACR – on selected models

Standard	HW415R-01	HW420R-01
RACR® 	HWC415R-01	HWC420R-01
Case Colour	Red	Red
Hose Size (ID)	12mm (1/2")	12mm (1/2")
Hose Length	15m (50ft)	20m (65ft)
Hose Material	High Temp. Chemical Resistant PVC	
Working Pressure	290psi at 20°C 100psi at 80°C	
Max Temperature	85°C (185°F)	85°C (185°F)
Reel Inlet	1/2" BSP (F)	1/2" BSP (F)
Hose Outlet	1/2" BSP (M)	1/2" BSP (M)

Applications:

Cleaning food processing area and equipment in meat, poultry, confectionery and dairy. Hot water wash down areas including bars, clubs, commercial kitchen and service centre

Service Parts:

- See page 240 for service kits and parts

Recommended to
be used with:

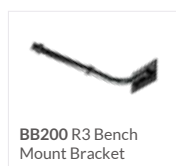

BB200 R3 Bench
Mount Bracket

WATER - COLD WATER



The Retracta R3 - Cold Water reel is ideal for industrial applications requiring cold water delivery using a brass snap-on fitting.

Unique patented RACR
(on selected models)

Working pressure
150psi

Available in
15m and 20m variants



1/2" (12mm) ID hose

Flexible & abrasive
resistant hose cover

Premium Reinforced
PVC hose

Includes spray nozzle

Why choose this product?

The Retracta R3 Cold Water reel is suited for industrial applications requiring high pressure water delivery via brass snap-on fitting.

Features & Benefits

- Premium reinforced PVC hose pressure rated to 150psi
- Brass hose connector
- Fully serviceable
- RACR – on selected models

Standard	CW415B-01	CW420B-01
RACR® 	CWC415B-01	CWC420B-01
Case Colour	Blue	Blue
Hose Size (ID)	12mm (1/2")	12mm (1/2")
Hose Length	15m (50ft)	20m (65ft)
Hose Material	Premium reinforced PVC	
Working Pressure	150psi	150psi
Max Temp.	60°C (140°F)	60°C (140°F)
Reel Inlet	1/2" BSP (F)	1/2" BSP (F)
Hose Outlet	Brass hose connector	Brass hose connector

Applications:

Food and industrial wash down application.
Outdoor, Garden and Horticultural

Service Parts:

- See page 240 for service kits and parts

Recommended to
be used with:

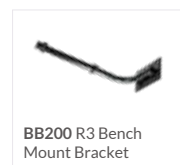

Retracta R3 Series

WATER - HIGH PRESSURE

10
YEARS
MACNAUGHT
WARRANTY*

The Retracta R3 – High Pressure reel is coupled with a steel wire braided rubber hose and industrial strength hose reel case ensuring complete confidence in high pressure water delivery.

Unique patented RACR
(on selected models)

Working pressure
3,000psi

Premium Wire Reinforced
Rubber Hose



3/8" (10mm) ID hose

Abrasive resistant
hose cover

Fully Serviceable

Why choose this product?

The Retracta R3 High Pressure reel is the ultimate in high pressure water delivery. Rated to pressures up to 3000psi and temperatures up to 95°C this reel and hose combination also delivers confidence in most water applications.

Features & Benefits

- Hose applicable for high pressure applications up to 3,000psi
- Rated to water temperatures up to 95°C
- Fully serviceable
- RACR – on selected models

Standard	HP320R-01
RACR® 	HPC320R-01
Case Colour	Red
Hose Size (ID)	10mm (3/8")
Hose Length	20m
Hose Material	Wire Reinforced Rubber
Working Pressure	3000 psi
Max Temperature	95°C (203°F)
Reel Inlet	3/8" BSP (F)
Hose Outlet	3/8" BSP (M)

Applications:

Outdoor high pressure cleaning, industrial cleaning, car wash

Service Parts:

- See page 240 for service kits and parts

Recommended to
be used with:



BB200 R3 Bench
Mount Bracket

WATER - GARDEN/HORTICULTURE

10
YEARS
MACNAUGHT
WARRANTY*

The Retracta R3 – Garden/Horticulture reel is available in 2 different reel case colours and come standard with the innovative RetractaFLEX hybrid polymer hose.



Why choose this product?

The Retracta R3 Garden/Horticulture looks as good as it works in garden and horticultural applications. Available in 2 different colours, the innovative RetractaFLEX hose comes standard.

Features & Benefits

- Hybrid polymer hose to prevent hose tangles and kinking.
- High wear resistance mouth with ProGlide
- Fully serviceable
- RACR – on selected models

Standard	DR418G-03	DR418P-03
RACR® 	DRC418G-03	DRC418P-03
Case Colour	Green	Beige
Hose Size (ID)	12mm (1/2")	12mm (1/2")
Hose Length	18m	18m
Hose Material	RetractaFLEX Hybrid Polymer	
Working Pressure	150 psi	150 psi
Max Temperature	60°C (140°F)	60°C (140°F)
Reel Inlet	Hose & Tap Connector	
Hose Outlet	Hose Connector	Hose Connector

Applications:

Domestic outdoor, garden and horticultural.

Service Parts:

- See page 240 for service kits and parts

Recommended to be used with:

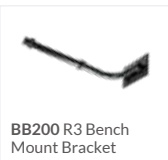

Retracta R3 Series

OIL

10
YEARS
MACNAUGHT
WARRANTY*

The Retracta R3 Oil reels are supplied with two different lengths of hoses supported by a black or blue reel. The R3 Premium can be upgraded with the RACR system offering true control by allowing the user to set the speed of return to suit their individual requirements.

Unique patented RACR
(on selected models)

Available in
3/8" (10mm) and 1/2"
(12mm) hose sizes

Working pressure
1,000psi

Abrasive resistant
smooth hose cover

Premium SAE Wire
Reinforced Rubber Hose

Fully Serviceable

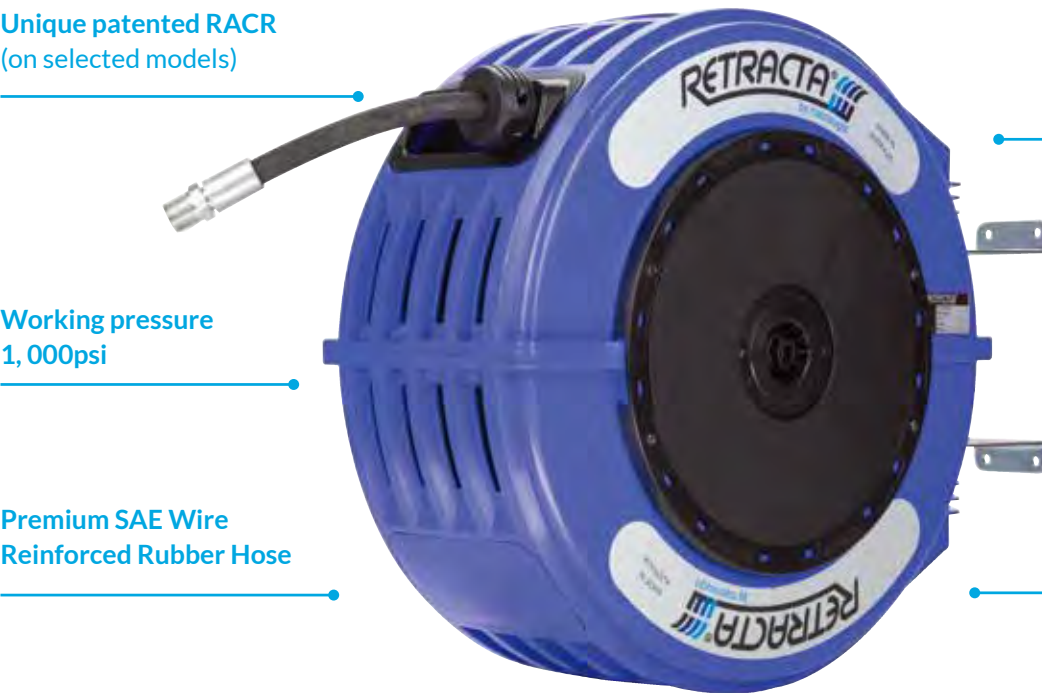

Also available
in a Dark Grey
Case

Why choose this product?

The R3 oil reels are ideal choice for peace of mind reliability and performance.

Applications:

Suitable for use across all industries

Features & Benefits

- Highly durable Double Reinforced Rubber (R3 Premium) or Steel Wire Braided Rubber
- Upgraded main spring made with TRC – Texture Rolled Carbon
- Safe tensioning mechanism
- High wear resistance mouth with ProGlide
- Fully serviceable
- RACR® – on selected models

Service Parts:

- See page 240 for service kits and parts

OIL

10
YEARS
MACNAUGHT
WARRANTY*

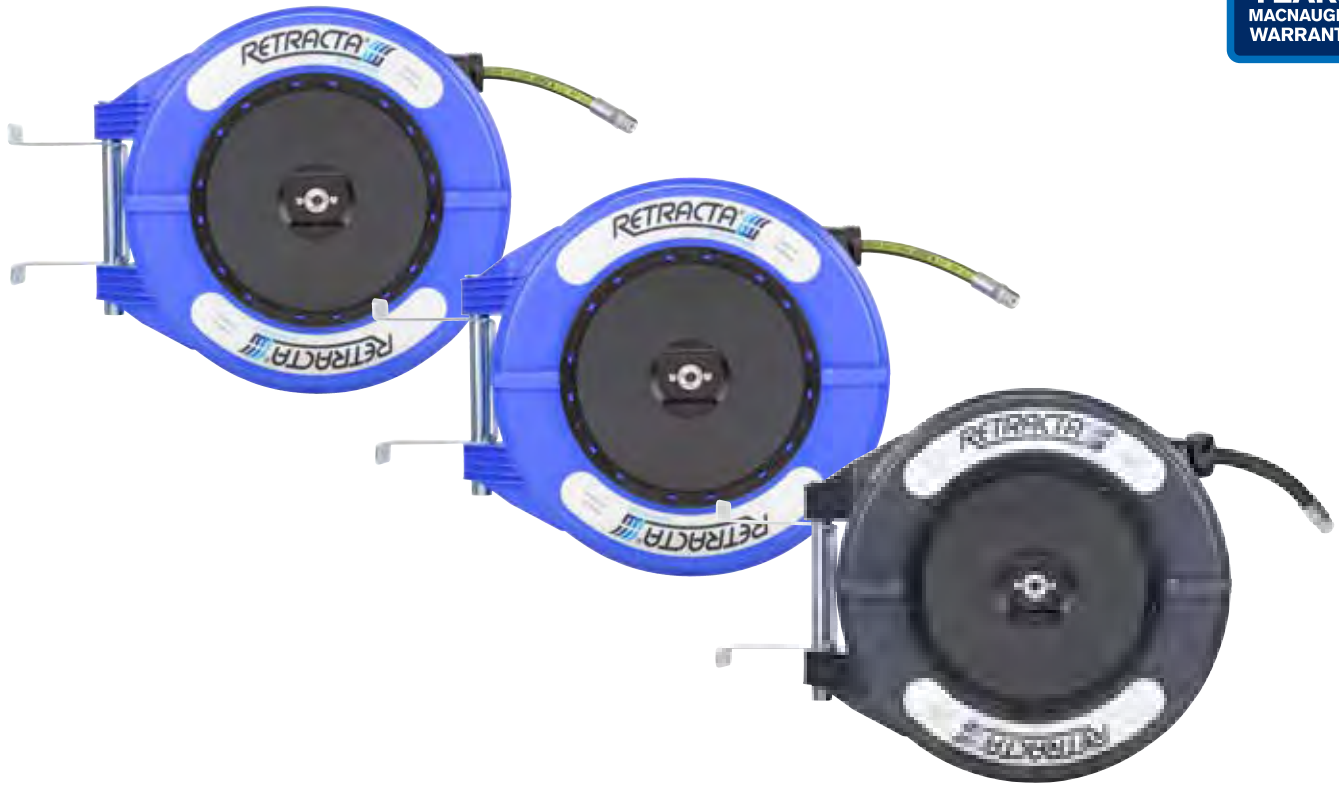

Standard	OMP310B-01	OMP415B-01	OMP415D-01
RACR® 	X	OMPC415B-01	OMPC415D-01
Case Colour	Blue	Blue	Dark Grey
Hose Size (ID)	10mm (3/8")	12mm (1/2")	12mm (1/2")
Hose Length	10m	15m	15m
Hose Material	Wire Reinforced Rubber (SAE100R1)	Wire Reinforced Rubber (SAE100R17)	Wire Reinforced Rubber (SAE100R17)
Working Pressure	1000 psi	1000 psi	1000 psi
Max Temperature	90°C (194°F)	90°C (194°F)	90°C (194°F)
Reel Inlet	1/2" BSP (F)	1/2" BSP (F)	1/2" BSP (F)
Hose Outlet	1/2" BSP (M)	1/2" BSP (M)	1/2" BSP (M)

Recommended to be used with:



BB200 R3 Bench Mount Bracket



HG20R-01 Rigid Oil Control Gun (Page 67)



HG20R-012E-01 Metered Oil Control Gun (Page 69)



HG60-01 Metered Oil Control Gun (Page 73)



HG40-01 Metered Oil Control Gun (Page 73)

Retracta R3 Series

GREASE

10
YEARS
MACNAUGHT
WARRANTY*

The Retracta R3 Grease reels are supplied with 2 different lengths of hoses supported by a black or blue reel. The R3 Premium can be upgraded with the RACR system offering true control by allowing the user to set the speed of return to suit their individual requirements.

Unique patented RACR
(on selected models)

Available in
1/4" (6mm) hose sizes

Working pressure
5,000psi

Abrasive resistant
hose cover

Premium SAE Wire
Reinforced Rubber Hose

Fully Serviceable

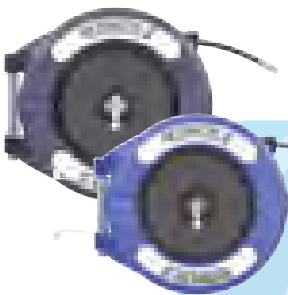

Also available
in a Blue or
Dark Grey Case

Features & Benefits

- Highly durable Double Reinforced Rubber (R3 Premium) or Steel Wire Braided Rubber
- Upgraded main spring made with TRC – Texture Rolled Carbon
- Safe tensioning mechanism
- High wear resistance mouth with ProGlide
- Fully serviceable
- RACR® – on selected models

Why choose this product?

The R3 grease reels are ideal choice for peace of mind reliability and performance.

Applications:

Suitable for use across all industries

Service Parts:

- See page [240](#) for service kits and parts

GREASE

10
YEARS
MACNAUGHT
WARRANTY*



Standard	GR210B-01	GR215D-01	GR215K-01
RACR® 	X	GRC215D-01	GRC215K-01
Case Colour	Blue	Dark Grey	Black
Hose Size (ID)	6mm (1/4")	6mm (1/4")	6mm (1/4")
Hose Length	10m	15m	15m
Hose Material	Wire Reinforced Rubber (SAE100R2)		
Working Pressure	5000 psi	5000 psi	5000 psi
Max Temperature	100°C (212°F)	100°C (212°F)	100°C (212°F)
Reel Inlet	1/4" BSP (F)	1/4" BSP (F)	1/4" BSP (F)
Hose Outlet	1/4" BSP (M)	1/4" BSP (M)	1/4" BSP (M)

Recommended to be used with:



BB200 R3 Bench
Mount Bracket

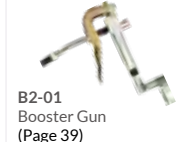

B2-01
Booster Gun
(Page 39)

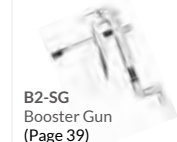

B2-SG
Booster Gun
(Page 39)

Retracta R3 Series

WELDING GAS - OXY/ACET

10
YEARS
MACNAUGHT
WARRANTY

The Retracta R3 Oxy/Acetylene reel is supplied with twin gas hose, made from reinforced rubber compliant to AS 1335 to ensure outstanding support in the welding environment. RACR version also available.

Unique patented RACR
(on selected models)

Working pressure
175psi

UNF Gas Thread



Twin 5mm (3/16") ID hose

Reinforced Rubber
(AS1335) Hose

Why choose this product?

Built for peace of mind reliability, performance and safety

Standard	OA215B-04
RACR® 	OAC215B-04
Case Colour	Blue
Hose Size (ID)	Twin 5mm (3/16")
Hose Length	15m
Hose Material	Reinforced Rubber (AS1335)
Working Pressure	175 psi
Max Temperature	80°C (176°F)
Reel Inlet	Gas Thread UNF (M)
Hose Outlet	Gas Thread UNF (F)

Features & Benefits

- Highly durable Double Reinforced Rubber
- Upgraded main spring made with TRC - Texture Rolled Carbon
- Safe tensioning mechanism
- High wear resistance mouth with ProGlide
- Fully serviceable
- RACR® - on selected models

Applications:

Suitable for use in all industries where Oxy /Acetylene is required

Service Parts:

- See page 240 for service kits and parts

Recommended to
be used with:



BB200 R3 Bench
Mount Bracket

WELDING GAS - OXY/LPG



The Retracta R3 Oxy/LPG reel is supplied with twin gas hose, made from reinforced rubber compliant to AS 1335 to ensure outstanding support in the welding environment. RACR version also available.

Unique patented RACR
(on selected models)

Working pressure
175psi

UNF Gas Thread



Twin 5mm (3/16") ID hose

Reinforced Rubber
(AS1335) Hose

Why choose this product?

Built for peace of mind reliability, performance and safety

Standard	OG215K-04
RACR® 	OGC215K-04
Case Colour	Black
Hose Size (ID)	Twin 5mm (3/16")
Hose Length	15m
Hose Material	Reinforced Rubber (AS1335)
Working Pressure	175 psi
Max Temp.	60°C (140°F)
Reel Inlet	Gas Thread UNF (M)
Hose Outlet	Gas Thread UNF (F)

Features & Benefits

- Highly durable Double Reinforced Rubber
- Upgraded main spring made with TRC - Texture Rolled Carbon
- Safe tensioning mechanism
- High wear resistance mouth with ProGlide
- Fully serviceable
- RACR® - on selected models

Applications:

Suitable for use in all industries where Oxy /LPG is required

Service Parts:

- See page 240 for service kits and parts

Recommended to be used with:



BB200 R3 Bench Mount Bracket

Retracta R3 Series

WELDING GAS - ARGON

10
YEARS
MACNAUGHT
WARRANTY*

The Retracta R3 Argon reel is supplied with a 20 metre hose, made from reinforced rubber compliant to AS 1335 to ensure outstanding support in the welding environment specifically to handle Argon. RACR version also available.

Unique patented RACR
(on selected models)

Working pressure
Up to 200psi

UNF Gas Thread



5mm (3/16") ID hose

Reinforced Rubber
(AS1335) Hose

Why choose this product?

The R3 Argon gas reel can be used in all applications for arc welding such as gas metal arc welding and gas tungsten arc welding.

Features & Benefits

- Highly durable Double Reinforced Rubber
- Upgraded main spring made with TRC - Texture Rolled Carbon
- Safe tensioning mechanism
- High wear resistance mouth with ProGlide
- Fully serviceable
- RACR® - on selected models

Standard	ARG220D-04
RACR® 	ARGC220D-04
Case Colour	Dark Grey
Hose Size (ID)	5mm (3/16")
Hose Length	20m
Hose Material	Reinforced Rubber (AS1335)
Working Pressure	200 psi
Max Temperature	60°C
Reel Inlet	Gas Thread UNF (M)
Hose Outlet	Gas Thread UNF (F)

Applications:

Service Bays / Garages, Manufacturing / Fabrication Shops, Construction, Welding Carts, Shipyards, Transport Service.

Service Parts:

- See page 240 for service kits and parts

Recommended to
be used with:



BB200 R3 Bench
Mount Bracket

WELDING GAS - LPG



The Retracta R3 LPG reel is supplied with a 20 metre hose, made from reinforced rubber compliant to AS 1335 to ensure outstanding support in the welding environment specifically to handle LPG. RACR version also available.

Unique patented RACR
(on selected models)

Working pressure
Up to 200psi

UNF Gas Thread



5mm (3/16") ID hose

Reinforced Rubber
(AS1335) hose

Why choose this product?

The R3 LPG hose reel has been created for the delivery and transfer of propane gas in commercial & industrial applications encased in a Retracta R3 reel.

Features & Benefits

- Highly durable Double Reinforced Rubber
- Upgraded main spring made with TRC - Texture Rolled Carbon
- Safe tensioning mechanism
- High wear resistance mouth with ProGlide
- Fully serviceable
- RACR® - on selected models

Standard	LPG220K-04
RACR® 	LPGC220K-04
Case Colour	Black
Hose Size (ID)	5mm (3/16")
Hose Length	20m
Hose Material	Reinforced Rubber (AS1335)
Working Pressure	200 psi
Max Temperature	60°C
Reel Inlet	Gas Thread UNF (M)
Hose Outlet	Gas Thread UNF (F)

Applications:

Service Bays / Garages, Manufacturing / Fabrication Shops, Construction, Welding Carts, Shipyards, Transport Service.

Service Parts:

- See page 240 for service kits and parts

Recommended to be used with:



BB200 R3 Bench Mount Bracket

Retracta R3 Series

CHEMICAL - WEEDICIDE / PESTICIDE

10
YEARS
MACNAUGHT
WARRANTY*

The Retracta R3 Weedicide/Pesticide reel is supplied with a 16 metre chemical resistant PVC hose designed specifically to handle, transfer and dispense weedicide, pesticide and chemical. RACR version also available.

Unique patented RACR
(on selected models)

Working Pressure: 250 psi



1/2" (12mm) ID hose

Chemical Resistant
PVC Hose

Why choose this product?

The R3 Weedicide/Pesticide hose reel has been created for the delivery and transfer of weedicide, pesticide and general chemicals.

Features & Benefits

- Highly durable Chemical resistant PVC
- Upgraded main spring made with TRC – Texture Rolled Carbon
- Safe tensioning mechanism
- High wear resistance mouth with ProGlide
- Fully serviceable
- RACR® – on selected models

Standard	WD316R-01
RACR® 	WDC316R-01
Case Colour	Red
Hose Size (ID)	10mm (3/8")
Hose Length	16m
Hose Material	Chemical Resistant PVC
Working Pressure	250 psi
Max Temperature	60°C (140°F)
Reel Inlet	3/8" BSP (F)
Hose Outlet	1/4" BSP (M)

Applications:

Farming, Horticulture, Chemical plant and Outdoor

Service Parts:

- See page 240 for service kits and parts

Recommended to
be used with:



BB200 R3 Bench
Mount Bracket

COOLANT



The Retracta R3 Coolant reel is supplied with a reinforced PVC hose to withstand coolant resistant to withstand most workshop coolants & chemicals. Choose from 15 or 20 metre for ready access anywhere around the workshop. RACR version also available.

Unique patented RACR (on selected models)

Working Pressure: 250 psi



3/8" (10mm) ID hose

Include Coolant dispensing nozzle

Reinforced PVC Hose

Why choose this product?

The R3 coolant reel is the ideal choice for workshop applications. Supplied with a coolant dispensing gun peace of mind reliability and performance.

Features & Benefits

- Highly durable Chemical resistant PVC
- Upgraded main spring made with TRC – Texture Rolled Carbon
- Safe tensioning mechanism
- High wear resistance mouth with ProGlide
- Fully serviceable
- RACR® – on selected models

Standard	CL315B-01	CL320D-01
RACR® 	X	CLC320D-01
Case Colour	Blue	Dark Grey
Hose Size (ID)	10mm (3/8")	10mm (3/8")
Hose Length	15m	20m
Hose Material	Reinforced PVC	
Working Pressure	250 psi	250 psi
Max Temp.	60°C (140°F)	60°C (140°F)
Reel Inlet	3/8" BSP (F)	3/8" BSP (F)
Hose Outlet	1/4" BSP (M)	1/4" BSP (M)

Applications:

Transport Service, Petrol/Service Station and Automotive Workshop

Service Parts:

- See page 240 for service kits and parts

Recommended to be used with:



BB200 R3 Bench Mount Bracket

Retracta R3 Series

F.R.A.S. AIR / WATER REEL

10
YEARS
MACNAUGHT
WARRANTY*

The Retracta R3 FRAS reel is supplied with a 15 metre reinforced PVC hose, featuring fire resistant anti-static property to meet the mining specific application. Reel constructed in polypropylene and brass, no aluminium.

Equipped with Fire Resistant Anti Static Hose

Working Pressure: 300 psi

Abrasive resistant hose cover



1/2" (12mm) ID hose

Reinforced PVC (F.R.A.S) Hose

*Fire Resistant Anti Static only applicable to hose, not including reel body

Why choose this product?

The Retracta FRAS reel features hose made with fire resistant material and a conductive outer strip connected to its conductive inner wall. Combine with our durable Retracta R3, it ideal for harsh mining environment.

Features & Benefits

- Highly durable reinforced PVC (F.R.A.S)
- Upgraded main spring made with TRC – Texture Rolled Carbon
- Safe tensioning mechanism
- High wear resistance mouth with ProGlide
- Fully serviceable
- RACR® – on selected models

Applications:

Food processing and food preparation. Hot water wash down areas including bars, clubs and service centres.

Service Parts:

- See page 240 for service kits and parts

Recommended to be used with:



BB200 R3 Bench Mount Bracket

Standard	FRAS415D-01
Case Colour	Dark Grey
Hose Size (ID)	12mm (1/2")
Hose Length	15m
Hose Material	Reinforced PVC (F.R.A.S)
Working Pressure	300 psi
Max Temperature	60°C (140°F)
Reel Inlet	1/2" BSP (F)
Hose Outlet	1/2" BSP (M)

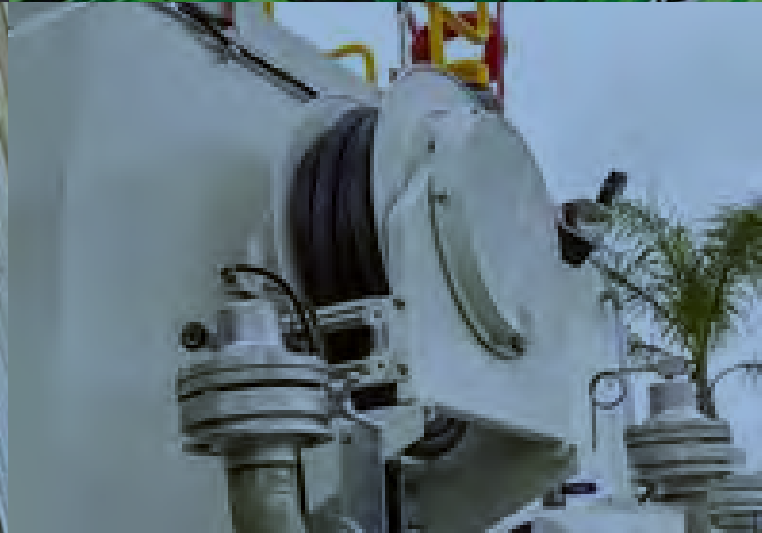

Retracta *F Series* HD Twin Pedestal

F-SERIES PEDESTAL

Built with demanding Australian conditions in mind, the heavy duty powder coated steel F-Series Twin Pedestal hose reel boasts sealed bearings, stainless steel shafts, solid three sector ratchets, Viton® O-rings, quality hoses and corrosion resistant fixings. A narrow face dimension has been maintained to allow multiple reels to be fitted in tight locations such as the mine site service vehicle. Industry common footprints allow for minimum changes to cabinet design. Common threads are used at inlet, outlet and hose fittings and spare parts are available.



High quality hose and fittings
Industrial grade, model specific hydraulic hose suitable for most common applications

Viton® O-rings

Fully Repairable
Replacement parts are available

Stainless Steel Shaft for multi fluid use
For multiple applications from oils and grease to water and coolants. Grease specific 3/8" high pressure model has zinc coated MS shaft.

High strength powder coated steel construction
For durability and use in arduous mobile conditions.

Adjustable roller guide arm
Allows multiple position mounting

Sealed Bearings
For longer life against dust and water ingress

1m connection hose included

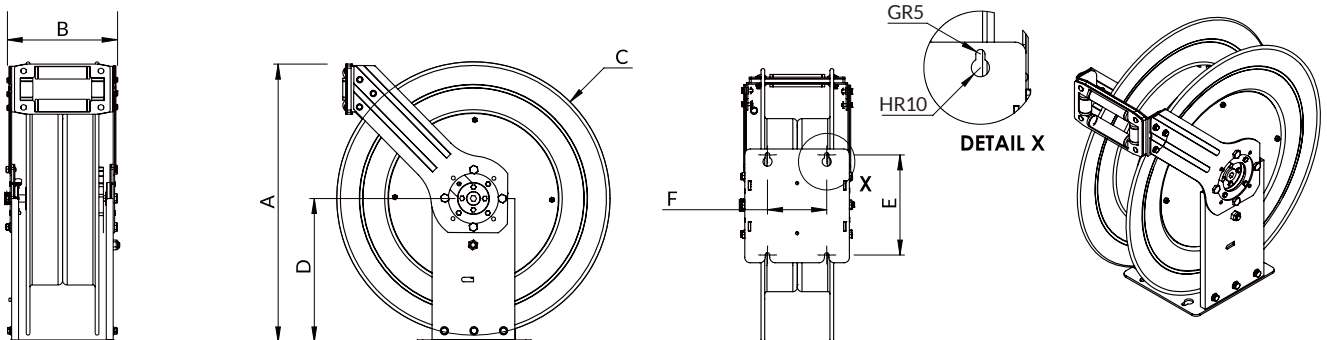
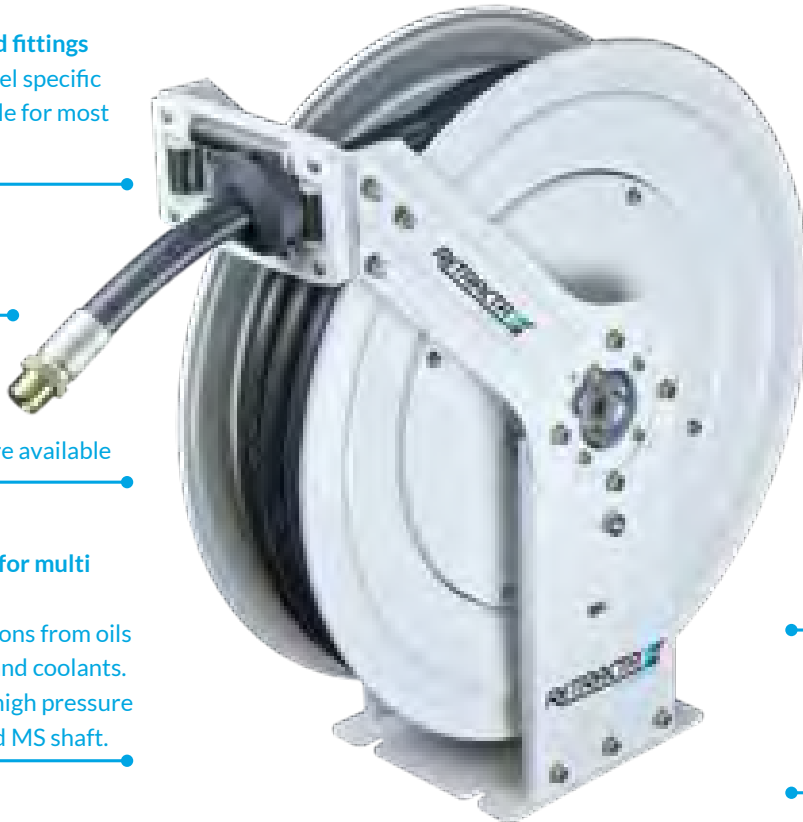

- 3/4" Twin Pedestal Reel Illustrated - Dimensions are in mm

Reel Dimension	A	B	C	D	E	F	G	H	Min Bend Radius
Reel 1	550	180	Ø515	280	216	130	R4.8	R10	140
Reel 2	600	248	Ø575	315	220	130	R5	R10	190

F-SERIES HEAVY DUTY TWIN PEDESTAL

Part Number	FHG0915-01	FHA1220-01	FHO1215-01	FHO1915-01
Application	Grease	Air/Water	Oil/Diesel	Oil/Diesel
Hose Size (ID)	10mm (3/8")	12mm (1/2")	12mm (1/2")	19mm (3/4")
Hose Length	15m	20m	15m	15m
Hose Material	3 Wire Rerforced Rubber	Reinforced PVC	Wire Reinforced Rubber (SAE 100R1)	Wire Reinforced Rubber (SAE 100R2)
Working Pressure	5000 psi	250 psi	2000 psi	1450 psi
Max Temperature	100° C	60° C	100° C	100° C
Reel Inlet	3/8" BSP (F)	1/2" BSP (F)	1/2" BSP (F)	3/4" BSP (M)
Hose Outlet	3/8" BSP (M)	1/2" BSP (M)	1/2" BSP (M)	3/4" BSP (M)
Reel Dimension	Reel 1	Reel 2	Reel 1	Reel 2

Part Number	FHM1200-01	FHM1900-01
Application	Air/Water/Oil	Air/Water/Oil
Hose Size (ID)	12mm (1/2")	19mm (3/4")
Hose Capacity	15m capacity	15m capacity
Hose Material	Bare Reel - hose excluded	
Working Pressure	2000 psi	1450 psi
Max Temperature	100° C	100° C
Reel Inlet	1/2" BSP (F)	3/4" BSP (F)
Swivel Outlet	1/2" BSP (F)	3/4" BSP (F)
Reel Dimension	Reel 1	Reel 2

Applications:

Suitable for all industries including underground mining applications

Service Parts:

- See page [243](#) and [244](#) for service kits and parts

Recommended to be used with:

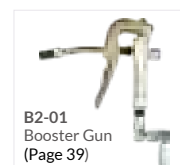

Retracta *F Series* HD Cradle

F-SERIES CRADLE

Built with demanding Australian conditions in mind, the heavy duty powder coated steel F-Series Cradle hose reel boasts sealed bearings, stainless steel shafts, solid three sector ratchets, Viton O'rings, quality hoses and corrosion resistant fixings. A narrow face dimension has been maintained to allow multiple reels to be fitted in tight locations such as the mine site service vehicle. Industry common footprints allow for minimum changes to cabinet design. Common threads are used at inlet, outlet and hose fittings and spare parts are available.



High quality hose and fittings
Industrial grade, model specific hydraulic hose suitable for most common applications

Fully Repairable
Replacement parts are available

High strength powder coated steel construction
For durability and use in arduous mobile conditions.

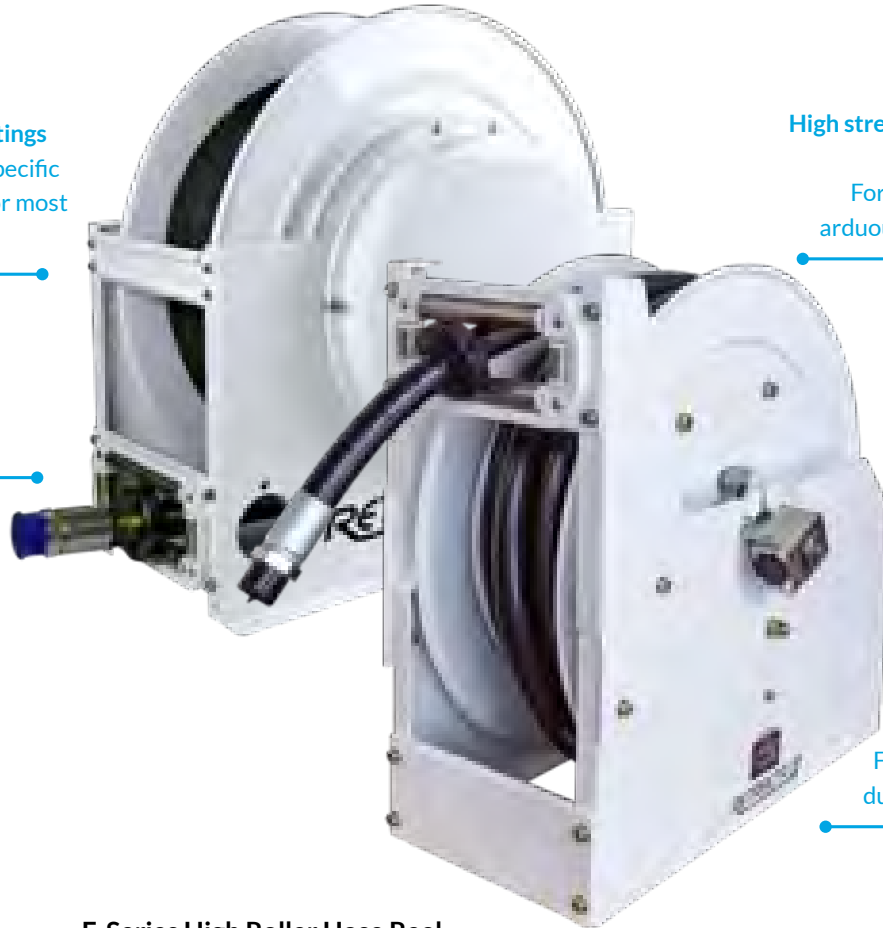

Sealed Bearings
For longer life against dust and water ingress

F-Series High Roller Hose Reel (F-Series High Roller Model)

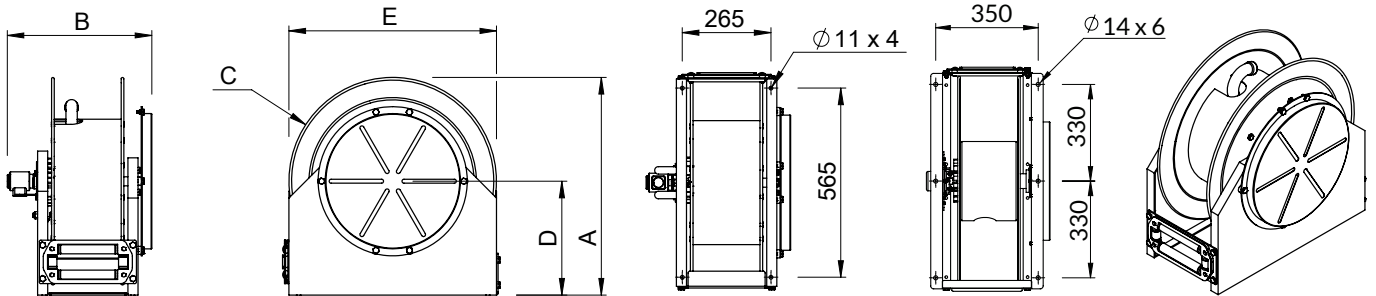

- Dimensions are in mm

Reel Dimension	A	B	C	D	E	Min Bend Radius
Reel 1	650	404	Ø620	340	620	180
Reel 2	728	425	Ø715	370	735	130

F-SERIES HEAVY DUTY CRADLE

Part Number	FHA1920-01	FCW2515-01	FCD2515-01	FCD3815-02
High Roller Part Number	FRW1920-01	FRW2515-01	FRD2515-01	FRD3815-02
Application	Air/Water	Air/Water	Oil/Diesel	Oil/Diesel
Hose Size (ID)	19mm (3/4")	25mm (1")	25mm (1")	38mm (1 - 1/2")
Hose Length	20m	15m	15m	15m
Hose Material	Reinforced PVC		Wire Reinforced Rubber (SAE 100R1)	
Working Pressure	250 psi	250 psi	1000 psi	500 psi
Max Temperature	60° C	60° C	100° C	100° C
Reel Inlet	3/4" BSP (F)	1" BSP (F)	1" BSP (F)	1 - 1/2" NPT (F)
Hose Outlet	3/4" BSP (M)	1" BSP(M)	1" BSP(M)	1 - 1/2" NPT (M)
Reel Dimension	Reel 1	Reel 1	Reel 1	Reel 2

Part Number	FCM2500-01	FCM3800-02
High Roller Part Number	FRM2500-01	FR M3800-02
Application	Air/Water/Oil/Diesel	Air/Water/Oil/Diesel
Hose Size (ID)	25mm (1")	38mm (1 - 1/2")
Hose Capacity	15m capacity	15m capacity
Hose Material	Bare Reel - hose excluded	
Working Pressure	1450 psi	500 psi
Max Temperature	100° C	100° C
Reel Inlet	1" BSP(F)	1 - 1/2" NPT (F)
Swivel Outlet	1" BSP(F)	1 - 1/2" NPT (F)
Reel Dimension	Reel 1	Reel 2

Applications:

Suitable for all industries including underground mining applications

Service Parts:

- See page 244 for service kits and parts

Recommended to be used with:

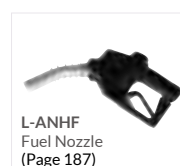

Retracta F Series Metered HD Twin Pedestal

F-SERIES METERED

The F-Series Metered hose reel represents the first hose reel developed worldwide with integrated flow meter and flow register. Offering unparalleled simplicity for OEMs, installers and users alike, there is no longer any need for separate mounting of meters, intermediate plumbing or vulnerable wiring between meters and registers. The reel comes completely fitted and wired to be placed in situ ready to function. The only installation required is bolting the unit down and the connection of the inlet fluids and outlet control. Although equally at home in static workshop situations, the F-Series range of metered hose reels has been specifically designed to meet the rigors of the mobile lube service vehicle.



Integrated Meter

Meter unit is protected by integration behind reel frame

Easy maintenance

Featuring simple maintenance anodised aluminium meter body.



Simple and easy to operate display

Clear digit display, simple programming and easy operation with robust powder coated steel register mount.

High quality hose and fittings

Capable of handling multiple fluids and tough conditions.

Small footprint

Suitable for service vehicle and narrow footprint requirements.

Part Number	FHXO1215-01	FHXO1915-01
Application	Oil/Diesel	Oil/Diesel
Hose Size (ID)	12mm (1/2")	19mm (3/4")
Hose Length	15m	15m
Hose Material	Wire Reinforced Rubber (SAE 100R1)	Wire Reinforced Rubber (SAE 100R2)
Working Pressure	2000 psi	1250 psi
Max Temperature	80° C	80° C
Reel Inlet	1/2" BSP (F)	3/4" BSP (F)
Hose Outlet	1/2" BSP (M)	3/4" BSP (M)
Meter Flow Rate	2 - 30 L/min	3 - 80 L/min
Meter Accuracy	0.5%	0.5%
Flow Meter Material	Aluminium	Aluminium
Reel Dimension	Reel 1	Reel 2

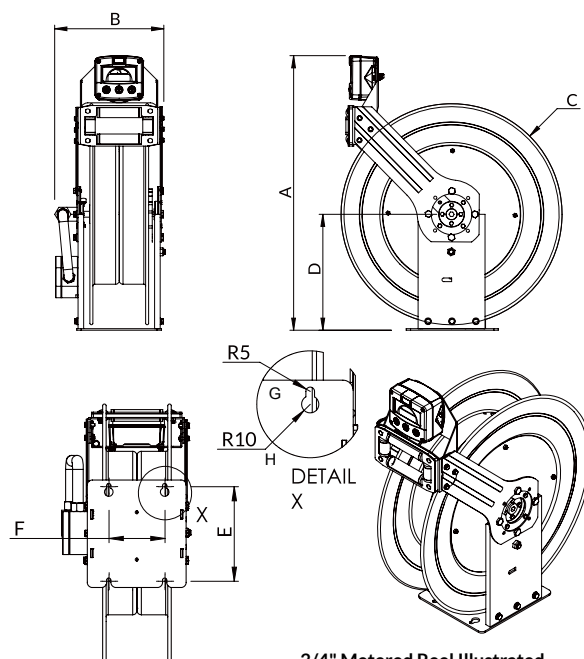

- 3/4" Metered Reel Illustrated
- Dimensions are in mm

Applications:

Automotive industry, transport workshop, truck workshop, regional farming centre, farming industry, mining service centre.

Service Parts:

- See page 244 for service kits /parts

Reel Dimension	A	B	C	D	E	F	G	H	Min Bend Radius
Reel 1	690	187	Ø515	280	216	130	R4.8	R10	140
Reel 2	745	296	Ø600	315	220	130	R5	R10	190

Retracta F Series Metered HD Cradle

F-SERIES CRADLE METERED



The F-Series Metered hose reel represents the first hose reel developed worldwide with integrated flow meter and flow register. Offering unparalleled simplicity for OEMs, installers and users alike, there is no longer any need for separate mounting of meters, intermediate plumbing or vulnerable wiring between meters and registers. The reel comes completely fitted and wired to be placed in situ ready to function. The only installation required is bolting the unit down and the connection of the inlet fluids and outlet control. Although equally at home in static workshop situations, the F-Series range of metered hose reels has been specifically designed to meet the rigors of the mobile lube service vehicle.

Integrated Meter

Meter unit is protected by integration behind reel frame

Durable heavy duty construction

Stainless Steel shaft suitable for mine service vehicle mounts and harsh operating conditions.

Cradle Structure

Metering unit fitted to reel with all required connection



Simple and easy to operate display

Clear digit display, simple programming and easy operation with robust powder coated steel register mount.

High quality hose and fittings

Capable of handling multiple fluids and tough conditions.

Small footprint

Suitable for service vehicle and narrow footprint requirements.

Part Number	FCXD2515-01	FCXM3815-02
Application	Oil/Diesel	Oil/Diesel
Hose Size (ID)	25mm (1")	38mm (1 - 1/2")
Hose Length	15m	15m
Hose Material	Wire Reinforced Rubber (SAE 100R1)	
Working Pressure	1000 psi	500 psi
Max Temperature	80° C	80° C
Reel Inlet	1" BSP (F)	1 - 1/2" NPT (F)
Hose Outlet	1" BSP(M)	1 - 1/2" NPT (M)
Meter Flow Rate	6 - 120 L/min	10 - 250 L/min
Meter Accuracy	0.5%	0.5%
Flow Meter Material	Aluminium	Aluminium
Reel Dimension	Reel 1	Reel 2

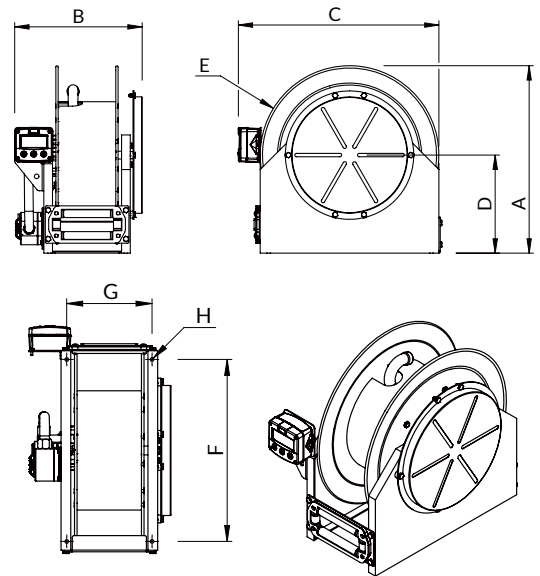

- 1" Metered Reel Illustrated
- Dimensions are in mm

Applications:

Automotive industry, transport workshop, truck workshop, regional farming centre, farming industry, mining service centre.

Service Parts:

- See page 244 for service kits /parts

Reel Dimension	A	B	C	D	E	F	G	H	Min Bend Radius
Reel 1	650	442	696	340	Ø620	565	265	Ø11x4	180
Reel 2	728	488	811	370	Ø715	660	350	Ø14x6	130

Retracta E Series



E-SERIES

Retracta E-Series fully enclosed hose reels have been developed to serve the needs of the Automotive industry. The neat, narrow design accommodates high density mounting in tight workshop bay environments. The E-Series hose reel is enclosed in a powder coated steel housing designed to protect against the ingress of contaminants while offering a sleek, clean appearance. Quality, industry standard hose and fitting used throughout. Fully repairable via simple side panel removal.

Narrow body

Made from powder coated, pressed steel for rigidity and protection.
Narrow footprint allows close mounting

Fully repairable

All parts available, no special tools required

Easy tensioning mechanism

Easy access to tensioning device.
No special tools required.



Easy access to swivel
No need to disassemble the entire reel to access the swivel for maintenance or hose change

Models available for multiple fluids
Oil, coolant, grease, compressed air and water

Includes feeder hose

Part Number	ESGR0610	ESAW1015-01	ESAW1210-01	ESO1210-01
Application	Grease	Air/Water	Air/Water	Oil
Hose Size (ID)	6mm (1/4")	10mm (3/8")	12mm (1/2")	12mm (1/2")
Hose Length	10m	15m	10m	10m
Hose Material	Wire Reinforced Rubber	Reinforced PVC	Reinforced PVC	Wire Reinforced Rubber (SAE 100R1)
Working Pressure	4000 psi	200 psi	200 psi	1000 psi
Max Temperature	70° C	50° C	50° C	70° C
Reel Inlet	1/4" BSP (F)	3/8" BSP (F)	1/2" BSP (F)	1/2" BSP (F)
Hose Outlet	1/4" BSP (M)	3/8" BSP (M)	1/2" BSP (M)	1/2" BSP (M)

Applications:

Automotive industry,
Transport workshop,
Truck workshop,
Regional farming centre,
Farming industry.

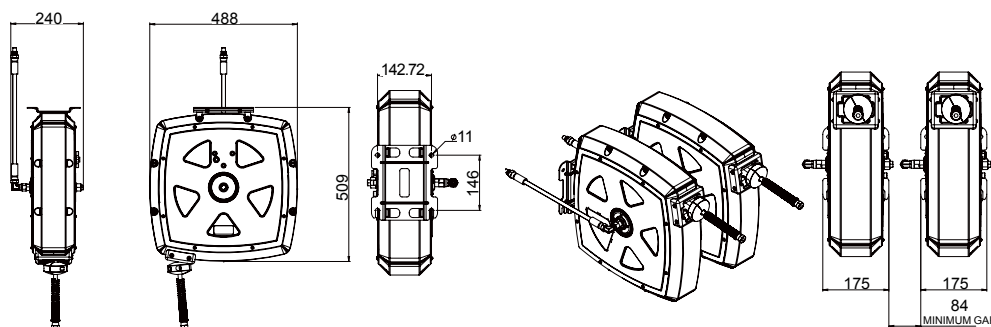

Recommended to be used with:



Retracta H Series

H-SERIES

Retracta H-Series composite hose reels offer superior impact and corrosion resistance thanks to the ABS drum. These reels are perfect for the rigours of transport and general industry. The light weight drum fittings and sturdy twin pedestal design allow fitment in fixed as well as mobile applications. Quality, industry standard hose and fitting used throughout. Fully repairable and comes with a 5 Year warranty.



Fully repairable

Industry standard hose and fitting

Stainless Steel 316 reel inlet,
PVC-PU hose



Sturdy Construction
Powder coated steel frame
with high strength ABS
drum

Full size flow path
3/4" flow path reduces
pressure drop

Part Number	HAB1908-01
Application	AdBlue® / DEF
Hose Size (ID)	19mm (3/4")
Hose Length	8m
Hose Material	PVC - PU
Working Pressure	200 psi
Reel Inlet	3/4" BSP (F)
Hose Outlet	3/4" BSP (M)

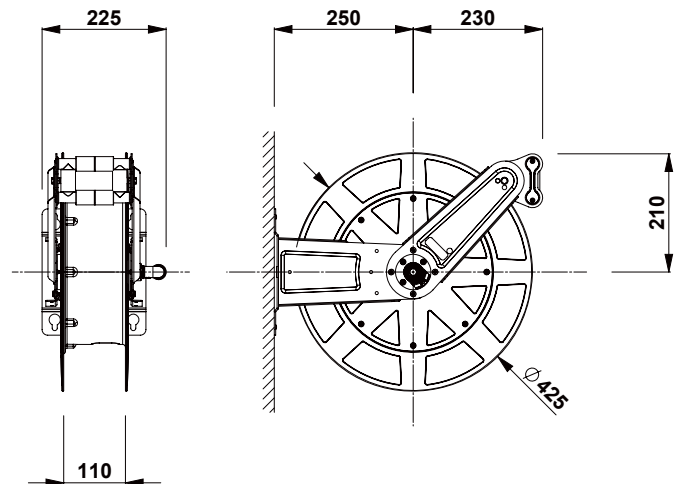
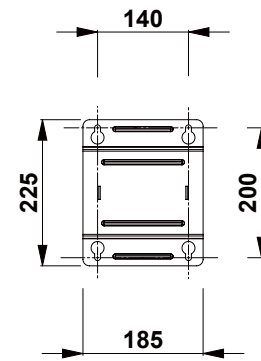

Applications:

Automotive industry, Transport workshop, Truck workshop, Regional farming centre, Farming industry.

Recommended to be used with:



Retracta *Capability Statement*

MACNAUGHT INDUSTRIAL HOSE REELS

In addition to the range of Retracta production reels, Macnaught offers an extended range of Retracta specialised project reel types built to order for larger applications.

Designed, engineered and developed to meet and exceed the needs of the most arduous applications, Retracta specialised project reels are offered in multiple construction materials, rewind power options, fluid types, pressure ratings and hose size.

Industrial grade fixings are used throughout construction and heavy bearings sealed against dust support the moving parts.



Common Applications

- Regional farming centres
- Truck/vehicle service centre
- Refill and dispensing station
- Lube bays
- Workshops
- Service truck/vehicle mounting

Available Options

Available construction materials:

- Fabrication aluminium
- Stainless steel - 304 or 316
- Powder coated steel + Aluminum
- Powder coated steel

Additional add-on features:

- Analogue Oval Gear Meters
- Digital Oval Gear Meters
- Oval flow meter with digital output
- Oval gear meters with digital display



Reel Construction Materials:

- Powder coated steel + Aluminum
- Powder coated steel
- Stainless Steel - 304 or 316

Meters

- Digital/Signal output
- Analogue/Mechanical display
- Digital display
- Display with 4-20mA output
- Display with batch control

Application / Fluid:

- Grease
- Diesel
- Oil
- Air
- Water
- Gas

Rewind Drive Systems:

- Manual
- Hydraulic
- Pneumatic
- Electric 12V-24V Spring

Hose size range:

- 6mm (1/4") to 50mm (2")



PROJECT ENGINEERED SOLUTIONS TO MEET YOUR REQUIREMENTS







LUBEMATE™ IN THE INDUSTRY

Macnaught proudly launched lubemate™ to provide the market with products that deliver value for every day jobs. Over the years, Lubemate products are exposed to the same testing and quality assurance processes, offering products that have been selected based on Macnaught's fuel, fluid and lubrication application and technical product knowledge.

The Lubemate range features equipment suitable for common grease, oil, fuel applications and hose reels. Lubemate™ products are selected by Macnaught to ensure that they are fit for purpose. Lubemate™ products are backed by a Macnaught warranty of up to 2 years*.

* Note: Subject to Macnaught warranty terms and conditions see macnaught.com/warranty or see page 267.

MANUAL GREASE GUNS

PISTOL-GRIP GREASE GUN PREMIUM L-PG450PV



One hand operation
Ergonomic design

12" High Pressure Grease hose
Fitted with 4 jaw coupler

Adjustable Stroke Mechanism
Enabling easy shift between high volume
and high pressure greasing



APPLICATIONS

Ideal for use in all manual greasing applications

Part Number	L-PG450PV
Description	PISTOL-GRIP GREASE GUN PREMIUM
L-C4 coupler	✓
Extension	300mm (12") - Flexible
Typical output pressure range	7,000psi (48,300kPa)
Output volume	0.84g/stroke
Cartridge	450g (16oz)
Bulk fillable	✓
Max grease type	NLGI No.2
Applications	All greasing applications

Recommended to be used with:



L-FX12, L-FX18
Flexible Extension
(Page 151)



L-C4
4 Jaw Grease Coupler
(Page 151)



L-QRC
Grease Coupler
(Page 150)



L-QRCXL
Long Nose Grease
Coupler
(Page 150)

LEVER-ACTION GREASE GUN
L-LG450

Heavy duty design
For durability and reliability

Supplied with both steel and flexible extensions
Provides flexibility for most greasing applications

Built tough
Quick reliable greasing



MINI-PISTOL GREASE GUN
L-MPG

Supplied with
4" steel extension and 4 jaw coupler

Trigger Action
For easy access

Small compact design
Ideal for toolbox and home applications

One hand Pistol grip grease gun
With convenient pull type operating mechanism

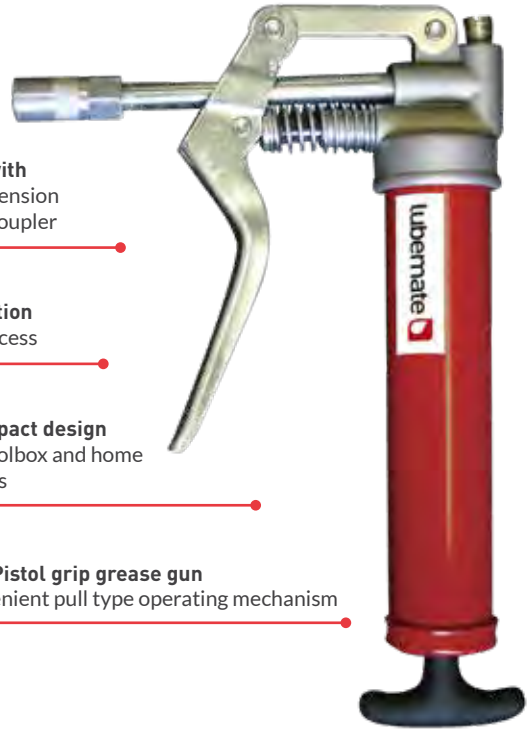

APPLICATIONS

Ideal for use in all manual greasing applications

Part Number	L-LG450	L-MPG
Description	LEVER-ACTION GREASE GUN PREMIUM	MINI-PISTOL GREASE GUN
L-C4 coupler	✓	✓
Extension	150mm (6") - Steel & 300mm (12") Flexible	100mm (4") - Steel
Typical output pressure range	10,000psi (69,000kPa)	3,500psi (24,000kPa)
Output volume	1g/stroke	0.4g/stroke
Cartridge	450g (16oz)	85g (3oz)
Bulk fillable	✓	✓
Max grease type	NLGI No.2	NLGI No.2
Applications	Designed for heavy industrial applications	Ideal for toolbox or home handyman applications where limited greasing is undertaken

Recommended to be used with:



L-FX12, L-FX18 Flexible Extension (Page 151)



L-C4 4 Jaw Grease Coupler (Page 151)



L-QRC Grease Coupler (Page 150)



L-QRCXL Long Nose Grease Coupler (Page 150)

AIR OPERATED GREASE GUNS

AIR OPERATED GREASE GUN L-AG450



Flexible Hose
12" (300 mm) with
professional 4 jaw coupler

**Heavy duty Aluminium
die cast head**
With internal bore precision
honed for rapid action

**Ergonomic pistol grip
and acute angle design**
Allows for ease of operation,
especially in narrow spaces

Continuous Flow Grease Gun
For fast continuous greasing

APPLICATIONS

Ideal for use in all greasing applications

Part Number	L-AG450
Description	AIR OPERATED GREASE GUN
L-C4 coupler	✓
Pressure Ratio	40:1
Extension	300mm (12") Flexible
Typical output pressure range	4,800psi (33, 100kPa)
Air inlet thread	1/4" (F)
Output volume	400g/min
Cartridge	450g (16oz)
Bulk fillable	✓
Air operating Range	40 -120psi (275 - 827kPa)
Max grease type	NLGI No.2
Air Consumption	1 cfm (0.026m ³ / min)

Recommended to be used with:



L-FX12, L-FX18
Flexible Extension
(Page 151)



L-C4
4 Jaw Grease Coupler
(Page 151)



L-QRC
Grease Coupler
(Page 150)



L-QRCXL
Long Nose Grease
Coupler
(Page 150)

BATTERY POWERED GREASE GUNS

18V LI-ION RECHARGEABLE BATTERY GREASE GUN

L-BG18VLI (Li-Ion)

The 18V Rechargeable Battery Grease Gun is a heavy duty, continuous flow, battery operated grease gun delivering flow rates up to 50g/min with pressures up to 7,500psi. Supplied complete with carry case, 2 x Li-Ion batteries, battery charger and meter long extension with coupler.



Supplied with 1m Flexible extension
Fitted with block nut and air-release valve

Hand carry case
Stores grease gun, cartridges batteries and charger

Cartridges
Suits 450g grease gun and bulk filling

2 x Lithium-Ion batteries
Twice the battery life to the standard Ni-cad equivalent

SPARE PARTS:

•L-BGBLI
18v Lithium Ion Battery



•L-BGCLI
Lithium Ion Charger



Part Number	L-BG18VLI
Description	18V LI-ION RECHARGEABLE GREASE GUN
Extension	1m (40")
Inlet/Outlet	1/8" NPT
Typical output pressure range	10,000psi (69,000kPa)
Output volume	50g/min (free flow)
Cartridge	450g (16oz)
Bulk fillable	✓
Max grease type	NLGI No.2
Battery Type	Lithium-Ion Battery - 18V

APPLICATIONS

Designed for use by mechanics, technicians, maintenance staff, farmers etc for everyday greasing and preventive maintenance jobs.

PACKAGE INCLUDES

- ✓ Carry case
- ✓ 2 x 18v Li-Ion batteries
- ✓ Li-Ion Battery charger
- ✓ Shoulder Strap
- ✓ 1m long extension with bend restrictor on both ends and coupler



Recommended to be used with:



L-QRC-02
NPT Grease Coupler
(Page 150)



KYPLUS-02
NPT Grease Coupler
(Page 31)

BATTERY POWERED GREASE GUNS

18V NI-CAD RECHARGEABLE BATTERY GREASE GUN

L-BG18V (Ni-Cad)

The 18V Rechargeable Battery Grease Gun is a heavy duty, continuous flow, battery operated grease gun delivering flow rates up to 50g/min with pressures up to 7,500psi. Supplied complete with carry case, 2 x Ni-Cad batteries, battery charger and meter long extension with coupler.



Supplied with 1m flexible extension
Fitted with block nut and air-release valve

Hand carry case
Stores grease gun, cartridges batteries and charger

Cartridges
Suits 450g grease gun and bulk filling

2 x Ni-Cad batteries
For continuous and uninterrupted use

SPARE PARTS:



•L-BGB
18v Ni-Cad Battery

•L-BGC
Ni-Cad Charger

Part Number	L-BG18V
Description	18V NI-CAD RECHARGEABLE GREASE GUN
Extension	1m (40")
Inlet/Outlet	1/8" NPT
Typical output pressure range	9,500psi (65,500kPa)
Output volume	50g/min (free flow)
Cartridge	450g (16oz)
Bulk fillable	✓
Max grease type	NLGI No.2
Battery Type	Ni-Cad Battery - 18V

APPLICATIONS

Designed for use by mechanics, technicians, maintenance staff, farmers etc for everyday greasing and preventive maintenance jobs.

PACKAGE INCLUDES

- Carry case
- 2 x 18v Ni-Cad batteries
- Ni-Cad Battery charger
- Shoulder Strap
- 1m long extension with bend restrictor on both ends and coupler



Recommended to be used with:



L-QRC-02
NPT Grease Coupler
(Page 150)



KYPLUS-02
NPT Grease Coupler
(Page 31)

AIR OPERATED GREASE SYSTEMS

AIR OPERATED GREASING KIT

L-GK20 (20kg) | L-GK180 (180kg)



Contamination free greasing
Fitted with strainer at suction tube inlet for clean grease to the bearing

Supplied complete
With drum cover, rubber lined follower plate, 2.1m of high pressure grease hose, Z swivel & professional grease control valve

All metal construction
Fully CNC machined with hardened wear resistant moving parts



L-GK20TROLLEY:
20kg Grease System with Trolley

L-GK180TROLLEY: 180kg Grease System with Trolley



Part Number	L-GK20	L-GK180
Description	AIR OPERATED GREASING KIT - 20KG	AIR OPERATED GREASING KIT - 180KG
Pump ratio	50:1	50:1
Suited to pails	20kg (44lbs)	180kg (400lbs)
Flow rate	1.1Kg/min (2.4lb/min)	1.1Kg/min (2.4lb/min)
Max Output Pressure	7500psi (51,710kPa)	7500psi (51,710kPa)
Air Motor Diameter	63mm (2-1/2")	63mm (2-1/2")
Hose	2.1m (84")	2.1m (84")
Control gun	L-GCV	L-GCV
Max air pressure	150psi (1034kPa)	150psi (1034kPa)
Min air pressure	30psi (207kPa)	30psi (207kPa)
Air inlet	1/4" BSP (F)	1/4" BSP (F)
Pump outlet	1/4" BSP (F)	1/4" BSP (F)
Air consumption	8 cfm	8 cfm
Suction Tube Length	440mm (17-5/16")	950mm (37-3/8")
In-line Lubricator	✓	✓
Noise Level	81dB	81dB
Grease viscosity	Up to NLGI No.2	Up to NLGI No.2
Wetted Parts	Steel, Brass, Aluminium, Polyurethane & Nitrile Rubber	
Model with Trolley	L-GK20TROLLEY	L-GK180TROLLEY

ACCESSORIES:

- L-F180: Follower Plate Assembly 180kg
- L-F20: Follower Plate Assembly 20kg
- L-L20: Lid to suit L-GK20
- L-L180: Lid to suit L-GK180

SERVICE PARTS:

- L-KIT/TP/RP/G: Air Motor Kit
- L-KIT/BTM/RP-G: Pump Chamber Kit

APPLICATIONS

Suitable for all high pressure greasing applications across all industries

Recommended to be used with:

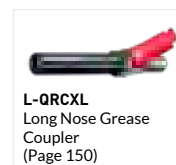

GREASE ACCESSORIES

QUICK RELEASE COUPLERS

L-QRC (Short Nose) | **L-QRCXL** (Long Nose)

The Lubemate quick release coupler is designed for use under high pressure. The unique red lever design makes uncoupling cleaner and effortless, allowing easier disconnection.



Four jaw design
Hardened jaws are resilient under high pressure

Compact size
Measuring only 74mm x 16mm allows for use in small, tight spaces.

Four jaw design
Hardened jaws are resilient under high pressure

Extra long - 129mm in length
Extra length for accessing hard to reach grease nipples.



Unique lever design
Makes coupling and uncoupling effortless

Unique lever design
Makes coupling and uncoupling effortless

Thread Options Available:

- L-QRC : 1 x 1/8" BSP (F) grease coupler
- L-QRC-02 : 1 x 1/8" NPT (F) grease coupler
- L-QRC-03 : 1 x M10X1 (F) grease coupler

- Quick release grease couplers offer you the choice of a short or long nozzle to access a wider range of areas to lubricate more effectively.

Part Number	L-QRC, L-QRC-02, L-QRC-03	L-QRCXL
Description	QUICK RELEASE GREASE COUPLER	QUICK RELEASE GREASE COUPLER LONG NOSE
Max pressure:	Up to 10,000psi	Up to 10,000psi
Inlet:	1/8"	1/8"
Thread:	BSP (F), NPT (F) and M10X1 (F) threads available	BSP (F)
Dimensions:	74mm x 16mm	129mm x 16mm
Weight	85g	165g

Recommended to be used with:

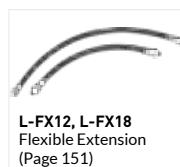
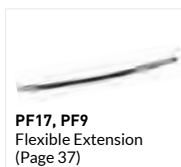

GREASE GUN FLEXIBLE EXTENSION

L-FX18 (450mm) L-FX12 (300mm)

- 450mm/300mm high pressure flexible extension
- Suitable for both manual and powered greasing equipment
- 1/8" BSPT (M) fittings on both ends
- Working pressure up to 40,000kPa (5,800psi)
- Burst pressure up to 95,000kPa (13,775psi)



4 JAW GREASE COUPLER

L-C4

- Max working pressure: up to 6,000psi
- Inlet: 1/8" BSP (F)
- Dimensions: 15mm diameter
- Weight: 40g



360° SWIVEL

L-ZS

- Swivels are installed between the delivery hose & grease control valve. These permit easy handling of control valves and prevent damage to hose caused by twisting.
- 1/4" BSPT(F) x 1/4" BSPT(M) fluid inlets



GREASE CONTROL VALVE

L-GCV

- Used with air operated equipment for grease delivery.
- Provides continuous grease flow with trigger fully pressed.
- Max working pressure up to 51,700kPa (7,500psi).
- 1/4" BSPT (F) fluid inlet.
- Comes with 150mm steel extension & 4 jaw coupler (360° swivel not included)

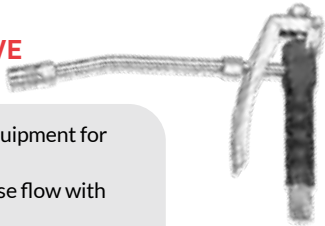

THREAD TESTER

L-GFTT

- Allows the different thread types to be checked easily



DRUM TROLLEY - 180KG

TR205-01

- Suitable for use with 180kg / 205L drums.
- Rugged build with outstanding features make these trolley ideal for use in workshops & industrial floors for transfer of large drums & buckets
- Heavy duty 8" swivel castor wheel with toe locks for higher safety & stability.
- Heavy duty 10" polyurethane front wheels with nylon rim for reduced wear & tear.



DRUM TROLLEY - 20KG

TR20G

- Suitable for use with 20kg grease pails.
- Ideal for transporting grease pails as well as installing air operated pump assemblies.
- Heavy Duty wheels for use in rigorous workshop environment.

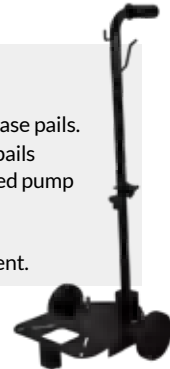

GREASE NIPPLES



All Lubemate Grease Nipples are Heat treated to SAE J534 specification with hardness on greasing end to a minimum of 83 on Rockwell 15N scale with a case depth of 0.005" (0.13 mm) to 0.009" (0.23 mm). Fittings with ball check use heat treated springs for increased life . Steel fittings are plated zinc with a plating thickness of 0.0002" (5 microns) conforming to SAE J534 specification & have a guaranteed salt spray life of over 72 hours to red rust. Fitting profile & dimensions are accurately controlled & confirm to SAE, DIN, BS, JIS & IS standards.



STRAIGHT METRIC GREASE NIPPLES

Product	Part number
6mm x 1 Tapered – Pack of 10	L-N061M-0
6mm x 1 Tapered – Pack of 50	L-N061M-0-B
8mm x 1 Tapered – Pack of 10	L-N081M-0
8mm x 1 Tapered – Pack of 50	L-N081M-0-B
8mm x 1.25 – Pack of 5	L-N08125M-0
8mm x 1.25 – Pack of 50	L-N08125M-0-B
10mm x 1 – Pack of 10	L-N101M-0
10mm x 1 – Pack of 50	L-N101M-0-B
10mm x 1.50 – Pack of 5	L-N1015M-0
10mm x 1.50 – Pack of 50	L-N1015M-0-B



STRAIGHT IMPERIAL GREASE NIPPLES

Product	Part number
¼" – 28 SAE -LT (UNF) – Pack of 10	L-N1428S-0
¼" – 28 SAE -LT (UNF) – Pack of 50	L-N1428S-0-B
1/8" – 27 NPT – Pack of 10	L-N1827N-0
1/8" – 27 NPT – Pack of 50	L-N1827N-0-B
¼" – 18 NPT – Pack of 5	L-N1418N-0
¼" – 18 NPT – Pack of 50	L-N1418N-0-B
1/8" – 28 BSPT – Pack of 10	L-N1828B-0
1/8" – 28 BSPT – Pack of 50	L-N1828B-0-B
¼" – 19 BSPT – Pack of 5	L-N1419B-0
¼" – 19 BSPT – Pack of 50	L-N1419B-0-B
¼" – 28 UNF – Pack of 10	L-N1428U-0
¼" – 28 UNF – Pack of 50	L-N1428U-0-B
5/16" – 24 UNF – Pack of 10	L-N51624U-0
5/16" – 24 UNF – Pack of 50	L-N51624U-0-B
3/8" – 24 UNF – Pack of 10	L-N3824U-0
3/8" – 24 UNF – Pack of 50	L-N3824U-0-B
¼" – 26 BSF – Pack of 10	L-N1426BSF-0
¼" – 26 BSF – Pack of 50	L-N1426BSF-0-B
5/16" – 22 BSF – Pack of 10	L-N51622BSF-0
5/16" – 22 BSF – Pack of 50	L-N51622BSF-0-B
3/8" – 20 BSF – Pack of 10	L-N3820BSF-0
3/8" – 20 BSF – Pack of 50	L-N3820BSF-0-B



90° METRIC GREASE NIPPLES

Product	Part number
6mm x 1 Tapered – Pack of 5	L-N061M-90
6mm x 1 Tapered – Pack of 50	L-N061M-90-B
8mm x 1 Tapered – Pack of 5	L-N081M-90
8mm x 1 Tapered – Pack of 50	L-N081M-90-B
10mm x 1 – Pack of 5	L-N101M-90
10mm x 1 – Pack of 50	L-N101M-90-B



90° IMPERIAL GREASE NIPPLES

Product	Part number
¼" – 28 SAE -LT (UNF) – Pack of 5	L-N1428S-90
¼" – 28 SAE -LT (UNF) – Pack of 50	L-N1428S-90-B
1/8" – 27 NPT – Pack of 5	L-N1827N-90
1/8" – 27 NPT – Pack of 50	L-N1827N-90-B
1/8" – 28 BSPT – Pack of 5	L-N1828B-90
1/8" – 28 BSPT – Pack of 50	L-N1828B-90-B
¼" – 19 BSPT – Pack of 5	L-N1419B-90
¼" – 19 BSPT – Pack of 50	L-N1419B-90-B



45° METRIC GREASE NIPPLES

Product	Part number
6mm x 1 Tapered - Pack of 5	L-N061M-45
6mm x 1 Tapered - Pack of 50	L-N061M-45-B
8mm x 1 Tapered - Pack of 5	L-N081M-45
8mm x 1 Tapered - Pack of 50	L-N081M-45-B
10mm x 1 - Pack of 10	L-N101M-45
10mm x 1 - Pack of 50	L-N101M-45-B



45° IMPERIAL GREASE NIPPLES

Product	Part number
1/4" - 28 SAE -LT (UNF) - Pack of 5	L-N1428S-45
1/4" - 28 SAE -LT (UNF) - Pack of 50	L-N1428S-45-B
1/8" - 27 NPT - Pack of 5	L-N1827N-45
1/8" - 27 NPT - Pack of 50	L-N1827N-45-B
1/8" - 28 BSPT - Pack of 5	L-N1828B-45
1/8" - 28 BSPT - Pack of 50	L-N1828B-45-B
1/4" - 19 BSPT - Pack of 5	L-N1419B-45
1/4" - 19 BSPT - Pack of 50	L-N1419B-45-B



STRAIGHT BUTTON 5/8" HEAD NIPPLES

Product	Part number
1/8" - 28 BSPT - Pack of 5	L-BH1828B
1/8" - 28 BSPT - Pack of 50	L-BH1828B-B
1/4" - 19 BSPT - Pack of 5	L-BH1419B
1/4" - 19 BSPT - Pack of 50	L-BH1419B-B
1/8" - 27 NPT - Pack of 5	L-BH1827N
1/8" - 27 NPT - Pack of 50	L-BH1827N-B
1/4" - 18 NPT - Pack of 5	L-BH1418N
1/4" - 18 NPT - Pack of 50	L-BH1418N-B



STRAIGHT STAINLESS STEEL NIPPLES

Product	Part number
1/8" - BSPT - Pack of 5	L-N1828B-0SS
1/8" - BSPT - Pack of 50	L-N1828B-0SS-B
10mm x 1 Tapered - Pack of 5	L-N101M-0SS
10mm x 1 Tapered - Pack of 50	L-N101M-0SS-B
1/8" - 27 NPT - Pack of 5	L-N1827N-0SS
1/8" - 27 NPT - Pack of 50	L-N1827N-0SS-B

GREASE NIPPLE KITS

12
MONTH
MACNAUGHT
WARRANTY*

SAE/NPT KIT 80 PIECES L-NP80S

TECHNICAL SPECIFICATION

This kit suits predominately older type US sourced equipment.
Kit contains:

- ✓ 15 only 1/4" - 28 SAE -LT(UNF) - Straight
- ✓ 10 only 1/4" - 28 SAE -LT(UNF) - 45°
- ✓ 10 only 1/4" - 28 SAE -LT(UNF) - 90°
- ✓ 25 only 1/8" - 27 NPT - Straight
- ✓ 10 only 1/8" - 27 NPT - 45°
- ✓ 10 only 1/8" - 27 NPT - 90°



METRIC KIT 80 PIECES L-NP80M

TECHNICAL SPECIFICATIONS

Suited for a more modern fleet where European or Japanese sourced equipment is found. Kit contains:

- ✓ 20 only M6 x 1 - Tapered - Straight
- ✓ 10 only M6 x 1 - Tapered - 90°
- ✓ 15 only M8 x 1 - Tapered - Straight
- ✓ 10 only M8 x 1 - Tapered - 90°
- ✓ 15 only M10 x 1 - Tapered - Straight
- ✓ 10 only M10 x 1 - Tapered - 90°



IMPERIAL KIT 50 PIECES L-NP50B

TECHNICAL SPECIFICATIONS

This kit is purpose designed for situations where older or US sourced equipment is deployed. Kit contains:

- ✓ 20 only 1/8" - 28 BSPT - Straight
- ✓ 5 only 1/8" - 28 BSPT - 45°
- ✓ 5 only 1/8" - 28 BSPT - 90°
- ✓ 10 only 1/4" - 19 BSPT - Straight
- ✓ 5 only 1/4" - 19 BSPT - 45°
- ✓ 5 only 1/4" - 19 BSPT - 90°



AGRICULTURAL KIT 110 PIECES L-NP110AG

TECHNICAL SPECIFICATIONS

More suited to a mixed fleet situation where imperial & metric sizes would be encountered. Kit contains:

- ✓ 20 only 1/8" - 28 BSPT - Straight
- ✓ 10 only 1/8" - 28 BSPT - 45°
- ✓ 10 only 1/8" - 28 BSPT - 90°
- ✓ 10 only M6 x 1 Tapered - Straight
- ✓ 6 only M6 x 1 Tapered - 45°
- ✓ 6 only M6 x 1 Tapered - 90°
- ✓ 10 only M8 x 1 Tapered - Straight
- ✓ 6 only M8 x 1 Tapered - 45°
- ✓ 20 only 1/4" - 28 UNF - Straight
- ✓ 10 only 1/8" - 27 NPT - Straight
- ✓ 2 only 4 jaw coupler



METRIC KIT 101 PIECES L-NP101M

TECHNICAL SPECIFICATIONS

Appropriate where either a late model fleet or European or Japanese sourced equipment is used. Kit contains:

- ✓ 30 only M6 x 1 Tapered - Straight
- ✓ 5 only M6 x 1 Tapered - 45°
- ✓ 10 only M6 x 1 Tapered - 90°
- ✓ 14 only M8 x 1 Tapered - Straight
- ✓ 5 only M8 x 1 Tapered - 90°
- ✓ 20 only M10 x 1 Tapered - Straight
- ✓ 5 only M10 x 1 Tapered - 45°
- ✓ 10 only M10 x 1 Tapered - 90°
- ✓ 1 only Easy-Out Tool - Small
- ✓ 1 only Easy-Out Tool - Large



MANUAL OIL PUMPS

20L OIL PUMP L-DP20J

Easy Operation
Delivers on down stroke
for easy operation



For different drum openings
2 additional drum thread adaptors included

Suitable hose
1.5m of PVC hose with anti-kink springs

20L PREMIUM OIL PUMP L-DP20P

D" handle grip
For easy downstroke operation

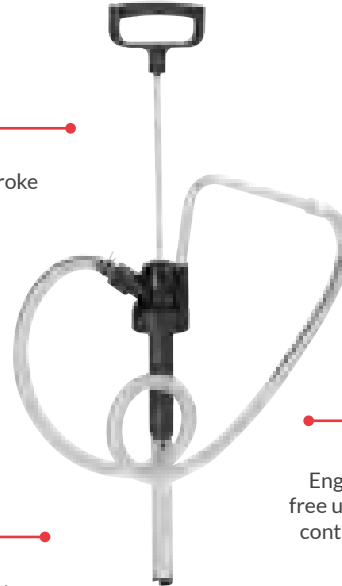

Drum Filler Plug
On the head helps in refilling the drum on which it is mounted without removing the pump from the drum.

Versatile Pump
Engineered for trouble free use on 20-25L (5 gal) containers with 2" bung

High density polyethylene pump head
Incorporates a nozzle holder & option to drain back over from fluid back into the container



Part Number	L-DP20J	L-DP20P
Description	20L OIL PUMP	20L PREMIUM OIL PUMP
Pump output	65ml/stroke	65ml/ stroke
Hose	1.5m of PVC hose with anti-kink springs	1.2m (4ft) Spring braided hose
Nozzle	Aluminum Spout	Non - drip Nozzle
Drum size	20-25L (5-6.5gal)	20-25L (5-6.5gal)
Drum adaptor	2 additional drum thread adaptors	Multiple adaptors included
Compatible fluids	Suitable for mineral oils up to SAE90 viscosity	Engine oils, gear oils up to SAE140 viscosity, glycerine, ATF's and RTU engine coolants (not concentrates)
Wetted Components	Nitrile, Steel and Polypropylene	Steel, aluminum, polyethylene, polypropylene co polymer, Viton®, PVC and acetal

APPLICATIONS: Suitable for use in all industries where 20ltr oil containers are used

Recommended to be used with:

TR20G
Drum Trolley
~20KG
(Page 39)



L-DT2060
Drum Trolley
(Page 177)



TR5-01
Drum Trolley -20L
(Page 39)



TR6-01
Drum Trolley -60L
(Page 39)



MANUAL OIL PUMPS

The Lubemate Lever-Action Barrel pump is suitable for lubricating oils up to SAE90, diesel, kerosene and service fluids.



LEVER-ACTION BARREL PUMP L-LBP



Ergonomic Handle

Plated steel lever handle with ergonomic rubber grip

Heavy Construction

Ribbed section aluminium die cast pump head for maximum strength

Delivery Output

Up to 300ml/stroke depending on viscosity

Bung Adaptors

Drum adaptors 1-1/2" and 2" bung adaptors suitable for 50-205L (13-54gal) drums

Part Number	L-LBP
Description	LEVER ACTION BARREL PUMP
Pump output	300ml/ stroke
Hose	x
Nozzle	Steel spout
Drum size	50-205L (13-54gal)
Drum adaptor	1 1/2" & 2" drum threads
Compatible fluids	Diesel, kerosene, lubricating oils to SAE90 and service fluids
Wetted Components	Steel, Aluminium, Zinc, Brass, NBR

APPLICATIONS: Suitable for use across all industries

Recommended to be used with:

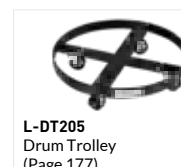
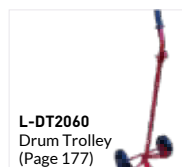
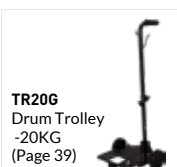

The Lubemate Spring Operated ATF/Gear oil pump has been designed to automatically dispense oil under spring pressure. Two versions are available suitable for 20L/60L drums.



20L ATF/GEAR OIL PUMP
L-SOP20

60L ATF/GEAR OIL PUMP
L-SOP60

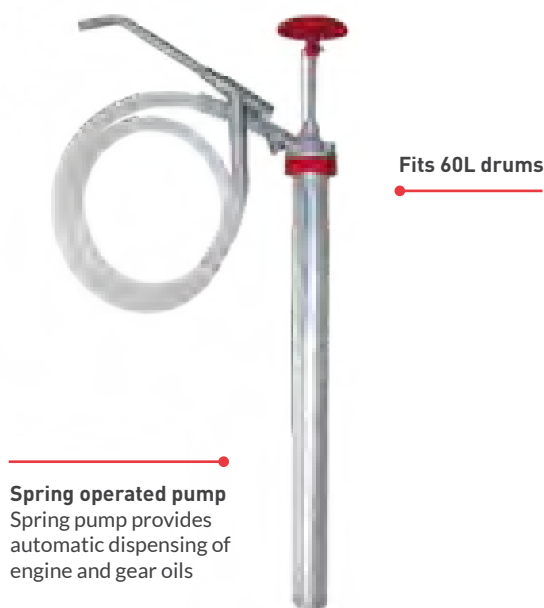

Part Number	L-SOP20	L-SOP60
Description	20L ATF/GEAR OIL PUMP	60L ATF/GEAR OIL PUMP
Pump output	340ml/ stroke	500ml/ stroke
Hose	1.5m (5ft) anti-kink hose	1.5m (5ft) anti-kink hose
Nozzle	Trigger dispensing gun	Trigger dispensing gun
Drum size	20L (5gal)	60L (16gal)
Drum adaptor	✓	✓
Compatible fluids	Lubricating oils up to SAE140 viscosity	Lubricating oils up to SAE140 viscosity
Wetted Components	Carbon Steel, Zinc, Polypropylene, Nitrile Rubber, Nylon and PVC	Carbon Steel, Zinc, Polypropylene, Nitrile Rubber, Nylon and PVC

APPLICATIONS: Ideal for use across all industries

Recommended to be used with:

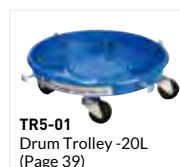
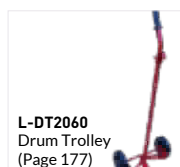

AIR OPERATED OIL PUMPS

Lubemate pneumatic pumps are designed to work in tough conditions and are ideal for use in Industry, workshop, farm, or as part of the Mobile Oil system.



AIR OPERATED OIL PUMP 1:1 L-ARPD1

Heavy duty construction
For a long, reliable service life

2" Bung Adaptor included

Built in strainer
Contamination free oil delivery



Built in strainer
Contamination free oil delivery

Double Acting Pistol Pump
Flow rate up to 40L/min (10.58 GPM)

AIR OPERATED OIL PUMP 3:1 L-ARPD3

Oil lubricator supplied
Prevents premature air motor wear

Built in strainer
Contamination free oil delivery

Double Acting Pistol Pump
Flow rate up to 14L/min (3.70 GPM)



Heavy duty construction
For a long, reliable service life

Part Number	L-ARPD1	L-ARPD3
Description	AIR OPERATED OIL PUMP 1:1	AIR OPERATED OIL PUMP 3:1
Pump ratio	1:1 ratio	3:1 ratio
Delivery output	40L/min (11gal/min)	14L/min (3.7gal/min)
Air Motor Diameter	2-1/2" (63mm)	2-1/2" (63mm)
Pump inlet	Suction tube	Suction tube
Pump outlet	1/2" BSP (F)	1/2" BSP (F)
Min air pressure	30psi (207 kPa)	30psi (207 kPa)
Max air pressure	150psi (1034kPa)	150psi (1034kPa)
Air inlet	1/4" BSP (F)	1/4" BSP (F)
Noise Level	81dB	81dB
Compatible fluids	Lubricating oils up to SAE80 viscosity	Lubricating oils up to SAE140 viscosity
Air Line Lubricator	✓	✓
Wetted Components	Steel, Brass, Aluminum, Hi Nitrile Rubber, Polyurethane & Nylon	Steel, Brass, Aluminum, Hi Nitrile Rubber, Polyurethane & Turcite

SERVICE PARTS:

- **L-KIT/01/T3/11B:** Air Motor Kit 1:1 Pump
- **L-KIT/NRV/T3/11B:** Non-Return Valve Kit 1:1 Pump
- **L-KIT/PST/T3/11B:** Piston Kit 1:1 Pump
- **L-KIT/SEL/T3/11B:** Seal Kit 1:1 Pump
- **L-KIT/T3/31B:** Air Motor Kit 3:1 Pump

APPLICATIONS: Suitable for use in most oil transfer systems and applications

Recommended to be used with:



OMP415B-01 Oil Reel
(Page 121)

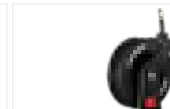

L-0S1215
Single Pedestal Metal Reel
(Page 196)



Lubemate Range of Oil Control Guns
(Page 166-171)

AIR OPERATED OIL PUMP KITS

The L-ARPD3 pump kit includes a premium quality (3:1) ratio air-operated oil drum pump, 3m (10ft) x 1/2" (12.5mm) oil hose, oil control gun (metered models available) with flex/rigid extension and non-drip nozzle. The kit has an approximate flow rate 10L/min with SAE10 oil and is suitable for oils up to SAE140, pre-mix coolants.



L-ARPD3-KIT2

- L-ARPD3 supplied with metered oil gun. Supplied with drum wrench, delivery hose and fittings.



L-ARPD3-KIT3:

- L-ARPD3 supplied with unmetered oil gun. Supplied with drum wrench, delivery hose and fittings.



Part Number	L-ARPD3-KIT2	L-ARPD3-KIT3
Description	3:1 RATIO OIL PUMP WITH HOSE AND DIGITAL OIL GUN	3:1 RATIO PUMP WITH HOSE & OIL GUN
Pump ratio	3:1	3.1
Pump	L-ARPD3	L-ARPD3
Outlet hose length	3m(10'ft) x12.5mm (1/2")	3m(10'ft) x12.5mm (1/2")
Oil Control Gun	L-MOGF	TD-01
Delivery output	Pump free flow - 14L/min (3.7gal/min)	Pump free flow - 14L/min (3.7gal/min)
Drum size	205L (54gal) drum	205L (54gal) drum
Digital Meter	✓	✗
Airline lubricator	Included	Included
Serviceable	✓	✓
Compatible fluids	Lubricating oils up to SAE140 viscosity	
Drum Wrench	Aluminium - 2"-3/4"	Aluminium - 2"-3/4"

Recommended to be used with:



OMP415B-01 Oil Reel (Page 121)



TR205 Trolley (Page 39)

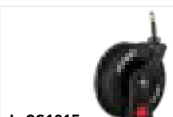

L-051215 Single Pedestal Metal Reel (Page 196)

APPLICATIONS: Automotive, Truck and Buses, Farming, Manufacturing, Construction and Earthmoving

AIR OPERATED OIL PUMP KITS



The L-ARPD3 pump kit includes a premium quality (3:1) ratio air-operated oil drum pump, 3m (10ft) x 1/2" (12.5mm) oil hose, oil control gun (metered models available) with flex/rigid extension and non-drip nozzle. The kit has an approximate flow rate 10L/min with SAE10 oil and is suitable for oils up to SAE140, pre-mix coolants.

L-ARPD3-KIT5

- L-ARPD3 supplied with metered oil gun. Supplied with drum wrench, delivery hose and fittings.



L-ARPD3-KIT6:

- L-ARPD3 supplied with preset metered oil gun. Supplied with drum wrench, delivery hose and fittings.



Part Number	L-ARPD3-KIT5	L-ARPD3-KIT6
Description	3:1 RATIO OIL PUMP WITH HOSE AND PREMIUM DIGITAL OIL GUN	3:1 RATIO OIL PUMP WITH HOSE AND PRESET DIGITAL OIL GUN
Pump ratio	3.1	3.1
Pump	L-ARPD3	L-ARPD3
Outlet hose length	3m(10'ft) x12.5mm (1/2")	3m(10'ft) x12.5mm (1/2")
Oil Control Gun	L-DOGFA	L-DPOCG
Delivery output	Pump free flow - 14L/min (3.7gal/min)	Pump free flow - 14L/min (3.7gal/min)
Drum size	205L (54gal) drum	205L (54gal) drum
Digital Meter	✓	✓
Airline lubricator	Included	Included
Serviceable	✓	✓
Compatible fluids	Lubricating oils up to SAE140 viscosity	
Drum Wrench	Aluminium - 2"-3/4"	Aluminium - 2"-3/4"

Recommended to be used with:



OMP415B-01 Oil Reel
(Page 121)



TR205
Trolley (Page 39)

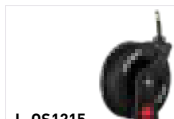

L-051215
Single Pedestal Metal
Reel (Page 196)

APPLICATIONS: Suitable for use across all industries in most oil transfer applications

MOBILE OIL EVACUATION SYSTEM

This portable/mobile quality system is designed for filling or removal of oil or waste oil from tanks/bulk containers.



MOBILE OIL EVACUATION SYSTEM EVACTR-LM

Suction tube and bung adaptor assembly
Included in kit

Long delivery hose
With lengthy hose for suction and delivery of fluids

Heavy duty TR205 drum trolley
Allows easy access and maneuverability as required



Cam lock fittings
Quick removal and connection

Four Way Valve
For easy change directional flow

3/4" Diaphragm Pump
Heavy Duty and reliable

Swivel caster with wheel lock break
For safety while in use

Package Includes

- ✓ M4WV19 - 3/4" Four way valve
- ✓ L-DDP19 - Double diaphragm pump
- ✓ TR205-01 - 205ltr Drum Trolley
- ✓ L-FS19 - 3/4" Swivel
- ✓ Suction tube assembly
- ✓ Camlock fittings
- ✓ All the required hoses and fittings

APPLICATIONS: Ideal for the removal and replacement of used waste oil and new oils and most other service fluids in industries such as: Automotive, agricultural, Lube truck and industrial service vehicle, Building and construction, mining, shipping. Suitable with new oil, waste oils and premix coolants.

OIL EQUIPMENT SYSTEMS

Trolley mounted kits are ideal for use in workshops, garages, shop floors providing complete portability for everyday oiling jobs. Designed for use with 55 gal. (205 Litre) Oil Drums, comes in non-assembled form & can be assembled quickly. Trolley can be locked with brakes provided on the wheels. Available in two variations with or without hose reel.

2
YEAR
MACNAUGHT
WARRANTY*

Premium oil dispensing gun
Accurate oil measurement

Complete system
Ready to use

Quality 3: Oil Pump
Robust, reliable oil pump

Quick connect hose fittings
For easy hose connection / disconnection during drum changes

Heavy duty 205ltr drum trolley
Position system where required



L-ARPT-1

Package Includes

- ✓ 3:1 Air Operated Oil Pump with 2" Bung
- ✓ 3m x 1/2" ID Oil Hose / Oil Hose Reel with 10m x 1/2" Oil Hose
- ✓ Digital Control Gun
- ✓ Drum Trolley
- ✓ Air Filter-Regulator & Lubricator

Recommended to be used with:



OMP415B-01 Oil Reel
(Page 133)



L-DPOCG
Digital Preset Oil Control Gun (Page 165)



Lubemate Range of Oil Control Guns
(Page 166-171)

OIL EQUIPMENT SYSTEMS



L-ARPT-1

- L-ARPD3 With Hose, Digital Oil Gun & 205L Drum Trolley

L-ARPTR-1

- L-ARPD3 With Retractable Oil Reel, Digital Oil Gun & 205L Drum Trolley

L-ARPD1-KIT1

- Oil Bar Kit - L-ARPD1 supplied with oil bar tap, jug and fittings.



Part Number	L-ARPT-1	L-ARPTR-1
Description	L-ARPD3 WITH HOSE, DIGITAL OIL GUN & 205L DRUM TROLLEY	L-ARPD3 WITH RETRACTA OIL REEL DIGITAL OIL GUN & 205L DRUM TROLLEY
Pump ratio	3:1	3.1
Pump	L-ARPD3	L-ARPD3
Delivery output	Pump free flow - 14L/min (3.7gal/min)	Pump free flow - 14L/min (3.7gal/min)
Oil Control Gun	L-MOGF	L-MOGF
Meter	✓	✓
Airline lubricator	Included	Included
Outlet hose length	3m (10'ft) x 12.5mm (1/2")	3m (10'ft) x 12.5mm (1/2")
Drum Wrench	Aluminium - 2"-3/4"	Aluminium - 2"-3/4"
Drum Trolley	TR205 - 205L Drum Trolley	TR205 - 205L Drum Trolley
Hose Reel	✗	Retractable Oil Reel 1/2" x 10m

Part Number	L-ARPD1-KIT1
Description	1:1 RATIO OIL PUMP WITH OIL BAR TAP & 5L JUG
Pump ratio	1:1
Pump	L-ARPD1
Delivery output	40L/min (11gal/min)
Oil Bar Tap	L-OBTPP
Drum size	205L (54gal) drum
Airline lubricator	Included
Compatible fluids	Lubricating oils up to SAE80 viscosity
Serviceable	✓
Measuring Jug	5L Plastic Measuring Jug

APPLICATIONS: Suitable for use in all mobile oil transfer applications

Recommended to be used with:



OMP415B-01 Oil Reel (Page 121)



L-DPOCG Digital Preset Oil Control Gun (Page 165)



Lubemate Range of Oil Control Guns (Page 166-171)

ELECTRIC OIL PUMPS

This 240V Oil Transfer Pump is a gear pump that enables the continuous extraction of oil. With this pump you no longer have the interruptions experienced using alternative oil pumps. This pump is also fan cooled ensuring safer, longer operation.



240V OIL TRANSFER PUMP L-OTP240V

Fan cooled

Ensuring safer longer operation without the interruptions experienced using alternative pumps



Self-priming gear pump
Reliable consistent oil delivery

Gear pump

Enables continuous extraction of oil

Suitable for oils
Up to SAE140 viscosity

Part Number	L-OTP240V
Description	240V OIL TRANSFER PUMP
Delivery output	40L/min (11gal/min)
Max Pressure	145psi
Inlet/Outlet	1" BSP (F)
Volts	240V AC, 50 Hz
Nominal Power	110W
Max. Current	6A
Operating temp.	-10°C (14°F) / +60°C (140°F)
Protection class	IP55
Compatible fluids	Suitable for oils up to SAE140 @ 20DegC viscosity
Duty Cycle	Continuous

APPLICATIONS: Suitable for most bulk oil transfer applications

DIGITAL PRESET OIL CONTROL GUNS

The Digital Preset Oil Gun provides an accurate programmable preset meter. The robust lightweight meter has an accuracy of +/- 0.5% of reading.



DIGITAL PRESET OIL CONTROL GUN L-DPOCG

Presettable oil gun
Offers 5 different dispense memory settings for common delivery volumes

Robust & lightweight design
Ergonomic plastic shell with shockproof rubber & the trigger guard prevents accidental operation

Flexible extension With auto nozzle
Easy access in tight spaces and auto nozzle to avoid fluid spillage with auto shut-off

High accuracy digital oval gear oil meter
5 digit easy to read, resettable LCD display with an accuracy of +/- 0.5%

Part Number	L-DPOCG
Description	DIGITAL PRESET OIL CONTROL GUN
Max pressure	1,000psi (6,900kPa)
Inlet port	1/2" swivel
Thread	BSP (F)
Flow range	1 - 35L/min (9gal/min)
Extension	Flexible
Nozzle	Automatic
Meter	Digital Preset with 5 different memory settings
Compatible fluids	Suitable for oils up to SAE140, engine oils, gear oils, ATF, hydraulic oils and premixed coolants
Accuracy	+/- 0.5%

APPLICATIONS: For use in oil dispensing systems where a preset auto shut off function is required

Recommended to be used with:



OMP415B-01 Oil Reel (Page 121)



L-OS1215 Single Pedestal Metal Reel (Page 196)



L-OTP1215 Twin Pedestal Metal Reel (Page 197)

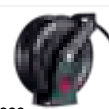

L-OTP1920 Heavy Duty Metal Reel (Page 198)



L-FEXA Flexible extension with Auto Nozzle (Page 177)



L-REXM Rigid extension with Manual Nozzle (Page 177)

OIL CONTROL GUNS - PREMIUM

The quality range of Lubemate oil control guns and meters are designed for use in the toughest conditions. All models are designed to be reliable and trouble free, an ideal inclusion into any oil dispensing application



DIGITAL OIL CONTROL GUN L-DOGFA



Accurate meter
+/-0.5%

Flexible Extension with Auto Nozzle
Easy access in tight spaces and auto nozzle to avoid fluid spillage with auto shut-off

Digital meter
5 digit easy to read LCD display

DIGITAL OIL CONTROL GUN L-DOGRM



Accurate meter
+/-0.5%

Rigid Extension with Manual Nozzle
Designed for normal day-to-day operations with rigid extension and manual nozzle

Digital meter
5 digit easy to read LCD display

Part Number	L-DOGFA	L-DOGRM
Description	DIGITAL OIL CONTROL GUN WITH FLEXIBLE EXTENSION & AUTO NOZZLE	DIGITAL OIL CONTROL GUN WITH RIGID EXTENSION & MANUAL NOZZLE
Max pressure	Up to 725psi (5,000kPa)	Up to 725psi (5,000kPa)
Inlet port	1/2" swivel	1/2" swivel
Thread	BSP (F)	BSP (F)
Flow range	Up to 35L/min (9gal/min)	Up to 35L/min (9gal/min)
Meter / register	Digital meter	Digital meter
Accuracy	+/- 0.5%	+/- 0.5%
Extension	Flexible	Rigid
Nozzle	Automatic	Manual
Compatible fluids	Suitable for oils up to SAE140, engine oils, gear oils, ATF, hydraulic oils and premixed coolants	

APPLICATIONS: Ideal addition to any oil dispensing system

Recommended to be used with:



OMP415B-01 Oil Reel
(Page 121)



L-OTP1215
Twin Pedestal Metal Reel
(Page 197)

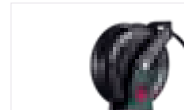

L-OTP1920
Heavy Duty Metal Reel
(Page 198)



L-FEXA
Flexible extension with
Auto Nozzle (Page 177)



L-REXM
Rigid extension with
Manual Nozzle (Page 177)

The quality range of Lubemate oil control guns and meters are designed for use in the toughest conditions. All models are designed to be reliable and trouble free, an ideal inclusion into any oil dispensing application



OIL CONTROL GUN L-OGFA



Flexible Extension with Auto Nozzle

Easy access in tight spaces and auto nozzle to avoid fluid spillage with auto shut-off

Ergonomic Design

Ergonomic design with shockproof rubber & the trigger guard prevents accidental operation

OIL CONTROL GUN L-OGRM



Rigid Extension with Manual Nozzle

Designed for normal day-to-day operations with rigid extension and manual nozzle

Robust & lightweight design

Ergonomic design with shockproof rubber & the trigger guard prevents accidental operation

Part Number	L-OGFA	L-OGRM
Description	OIL CONTROL GUN WITH FLEXIBLE EXTENSION & AUTO NOZZLE	OIL CONTROL GUN WITH RIGID EXTENSION & MANUAL NOZZLE
Max pressure	Up to 1,450psi (10,000kPa)	Up to 1,450psi (10,000kPa)
Inlet port	1/2" swivel	1/2" swivel
Thread	BSP (F)	BSP (F)
Flow range	Up to 35L/min (9gal/min)	Up to 35L/min (9gal/min)
Meter / register	X	X
Accuracy	X	X
Extension	Flexible	Rigid
Nozzle	Automatic	Manual
Compatible fluids	Suitable for oils up to SAE140, engine oils, gear oils, ATF, hydraulic oils and premixed coolants	

APPLICATIONS: Ideal addition to any oil dispensing system

Recommended to be used with:



OMP415B-01 Oil Reel
(Page 121)



L-0TP1215
Twin Pedestal Metal Reel
(Page 197)

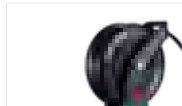

L-0TP1920
Heavy Duty Metal Reel
(Page 198)



L-FEXA
Flexible extension with
Auto Nozzle (Page 177)



L-REXM
Rigid extension with
Manual Nozzle (Page 177)

OIL CONTROL GUNS - STANDARD

The quality range of Lubemate oil control guns and meters are designed for use in the toughest conditions. All models are designed to be reliable and trouble free, an ideal inclusion into any oil dispensing application.



OIL CONTROL GUN AUTO NOZZLE L-OCGAE

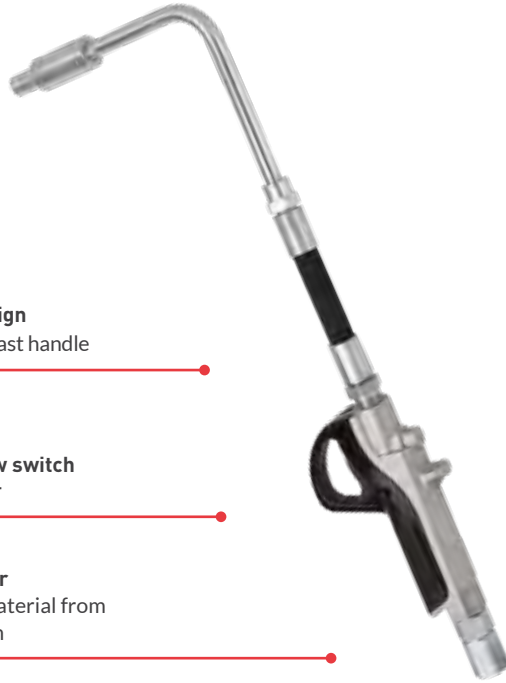

Compact and lightweight design
Aluminium die cast handle

Continuous flow switch
Lockable trigger

Built-in strainer
Stops foreign material from entering the gun

OIL CONTROL GUN MANUAL NOZZLE L-OCGME

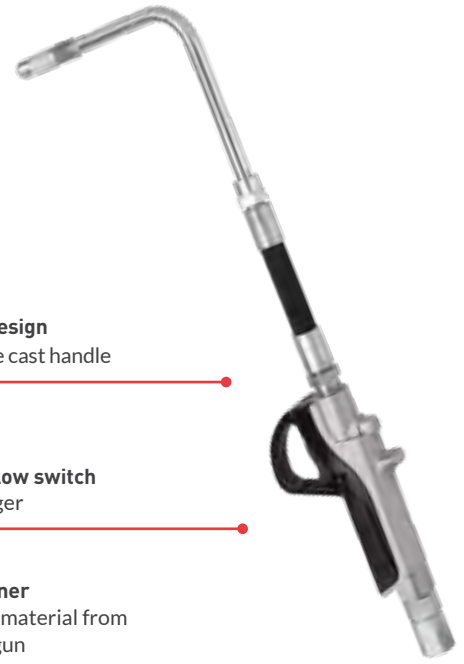

Compact and lightweight design
Aluminium die cast handle

Continuous flow switch
Lockable trigger

Built-in strainer
Stops foreign material from entering the gun

Part Number	L-OCGAE	L-OCGME
Description	OIL CONTROL GUN - AUTO NOZZLE	OIL CONTROL GUN - MANUAL NOZZLE
Max pressure	1,000psi (6,900kPa)	1,000psi (6,900kPa)
Inlet port	1/2" swivel	1/2" swivel
Thread	BSP (F)	BSP (F)
Flow rate	Up to 30L/min (8gal/min)	Up to 30L/min (8gal/min)
Extension	Flexible	Flexible
Nozzle	Automatic	Manual
Meter / register	X	X
Compatible fluids	Suitable for oils up to SAE140, engine oils, gear oils, ATF, hydraulic oils and premixed coolants	

APPLICATIONS: Ideal addition to any oil dispensing system

Recommended to be used with:



OMP415B-01 Oil Reel
(Page 121)



L-0TP1215
Twin Pedestal Metal Reel
(Page 197)



L-FEXA
Flexible extension with
Auto Nozzle (Page 177)



L-REXM
Rigid extension with
Manual Nozzle (Page 177)

The quality range of Lubemate oil control guns and meters are designed for use in the toughest conditions. All models are designed to be reliable and trouble free, an ideal inclusion into any oil dispensing application.



DIGITAL CONTROL GUN FLEXIBLE EXTENSION L-MOGF

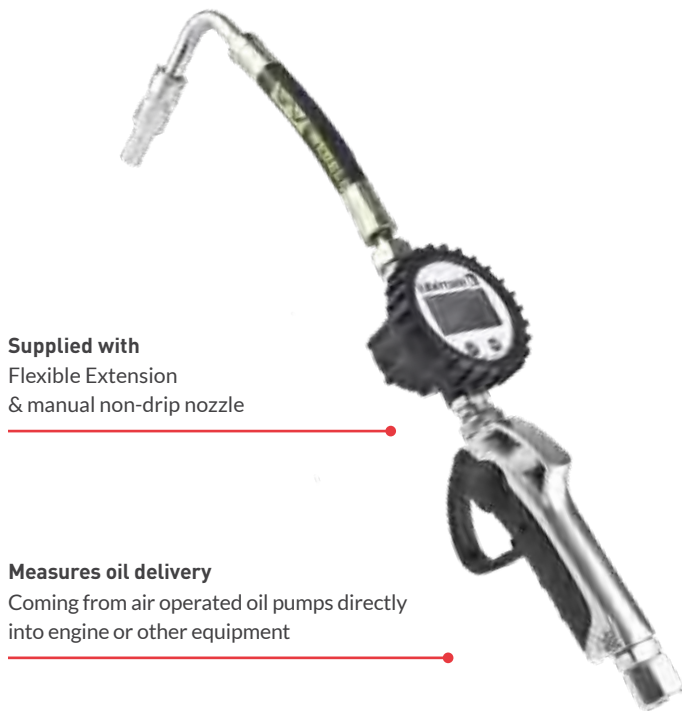

Supplied with Flexible Extension & manual non-drip nozzle

Measures oil delivery
Coming from air operated oil pumps directly into engine or other equipment

OIL CONTROL GUN FLEXIBLE EXTENSION TD-01

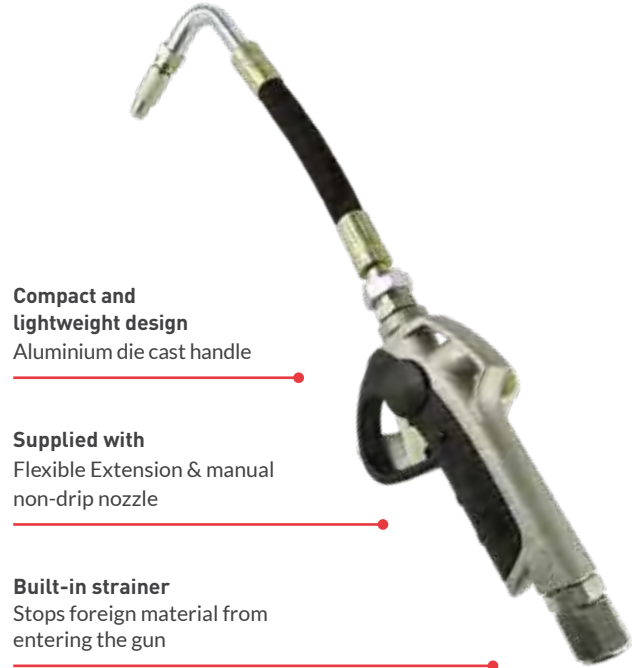

Compact and lightweight design
Aluminium die cast handle

Supplied with Flexible Extension & manual non-drip nozzle

Built-in strainer
Stops foreign material from entering the gun

Part Number	L-MOGF	TD-01
Description	DIGITAL CONTROL GUN FLEXIBLE EXTENSION	OIL CONTROL GUN FLEXIBLE EXTENSION
Max pressure	1,000psi (6,900kPa)	1,000psi (6,900kPa)
Inlet port	1/2" swivel	1/2" swivel
Thread	BSP (F)	BSP (F)
Flow rate	Up to 30L/min (8gal/min)	Up to 30L/min (8gal/min)
Extension	Flexible	Flexible
Nozzle	Manual	Manual
Meter / register	Digital meter	X
Compatible fluids	Suitable for oils up to SAE140, engine oils, gear oils, ATF, hydraulic oils and premixed coolants	

APPLICATIONS: Ideal addition to any oil dispensing system

Recommended to be used with:

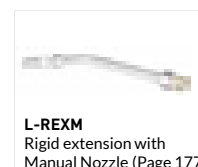
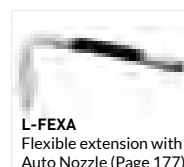
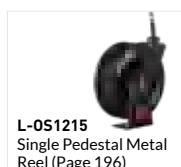

HIGH FLOW OIL CONTROL GUNS

The quality range of Lubemate™ High Flow oil control guns are designed for use in the toughest conditions. All models are designed to be reliable and trouble free, an ideal inclusion into any high flow oil dispensing application



HIGH FLOW OIL CONTROL GUN L-HFOG



2 position latch mechanism
Allows control of flow rate in two positions

Flexible extension with auto nozzle
Designed for heavy-duty work conditions and auto nozzle avoids fluid spillage

Compact and lightweight design
Made from aircraft grade aluminium for maximum strength & durability

High flow capacity
Flow rates up to 80L/min

APPLICATIONS: Suitable for high flow oil transfer

Part Number	L-HFOG
Description	HIGH FLOW OIL CONTROL GUN
Max pressure	1,450psi (10,000kPa)
Inlet port	3/4" Swivel
Thread	BSP (F)
Flow range	Up to 80L/min (21gal/min)
Meter / register	X
Accuracy	X
Extension	Flexible
Nozzle	Automatic
Compatible fluids	Suitable for oils up to SAE140, engine oils, gear oils, ATF, hydraulic oils and premixed coolants

Recommended to be used with:

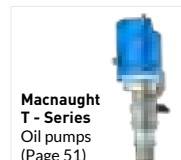
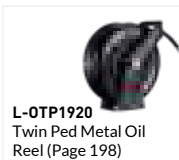

The quality range of Lubemate High Flow oil control guns are designed for use in the toughest conditions. All models are designed to be reliable and trouble free, an ideal inclusion into any high flow oil dispensing application



**DIGITAL HIGH FLOW OIL CONTROL GUN
L-DHFOG**

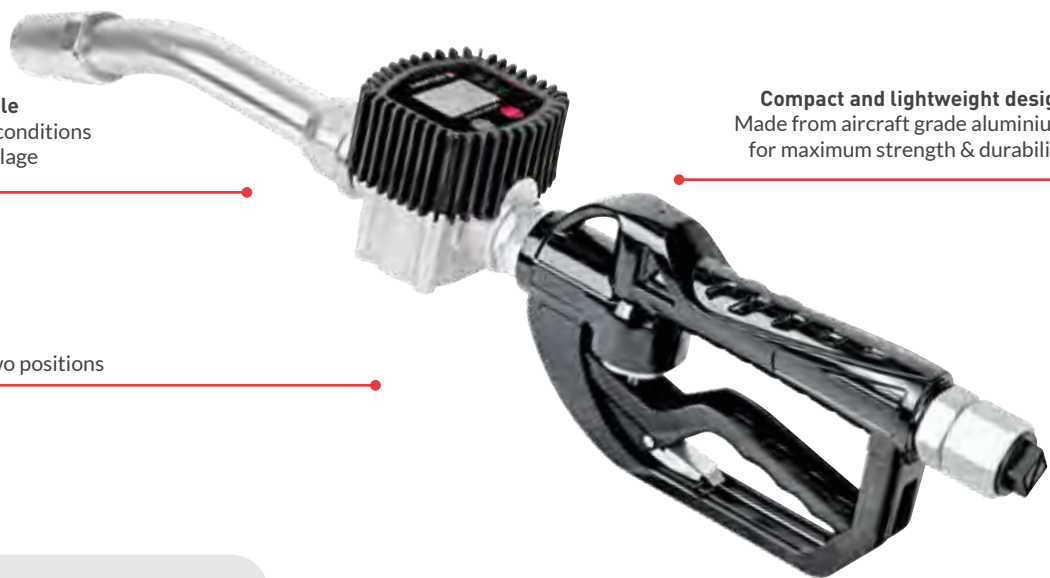

Rigid extension with auto nozzle
Designed for heavy-duty work conditions and auto nozzle avoids fluid spillage

High accuracy digital oil meter
5 digit easy to read, resettable LCD display

Compact and lightweight design
Made from aircraft grade aluminium for maximum strength & durability

2 position latch mechanism
Allows control of flow rate in two positions

APPLICATIONS: Suitable for high flow oil transfer

Part Number	L-DHFOG
Description	DIGITAL HIGH FLOW OIL CONTROL GUN
Max pressure	725psi (5,000kPa)
Inlet port	3/4" Swivel
Thread	BSP (F)
Flow range	Up to 80L/min (21gal/min)
Meter / register	Digital Oval gear
Accuracy	+/- 0.5%
Extension	Rigid
Nozzle	Automatic
Compatible fluids	Suitable for oils up to SAE140, engine oils, gear oils, ATF, hydraulic oils and premixed coolants

Recommended to be used with:



OIL BAR TAPS

The oil bar taps are the cost effective alternative to the conventional hose reel / gun dispensing arrangement. The Heavy duty oil bar taps are designed for trouble free reliability.



OIL BAR TAP WITHOUT METER L-OBTPP

Oil Bar Taps
Are an easy to use ergonomic alternative to hose dispensing



Built-in strainer outlet spout
Avoids splash during use

"S" shaped tube
Can be fitted direct to oil transfer pump outlet

Heavy duty construction
Makes it suitable to use on a wide range of pumps

OIL BAR TAP WITH METER L-DOBTP

Oil Bar Taps
Are an easy to use ergonomic alternative to hose dispensing

Built-in strainer Outlet spout
Avoids splash during use



Accurate digital meter
with 1 x 3.6V battery
5 digit easy to read, resettable LCD display

"S" shaped tube
Can be fitted direct to oil transfer pump outlet

Heavy duty construction
Makes it suitable to use on a wide range of pumps

Part Number	L-OBTPP	L-DOBTP
Description	OIL BAR TAP WITHOUT METER	OIL BAR TAP WITH METER
Max pressure	Up to 1,500psi (10,000kPa)	Up to 1,500psi (10,000kPa)
Inlet port	1/2"	1/2"
Thread	BSP (F)	BSP (F)
Flow range	Up to 35L/min (9gal/min)	Up to 35L/min (9gal/min)
Meter / register	X	Digital Oval Gear Meter
Accuracy	X	+/- 0.5%
Strainer outlet		✓
Compatible fluids	Suitable for oils up to SAE140, engine oils, gear oils, ATF, hydraulic oils and premixed coolants	

APPLICATIONS: Suitable for all oil dispensing application

Recommended to be used with:

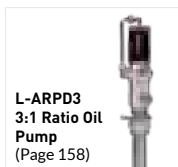

DIGITAL OIL METERS

The Lubemate range of digital oil meters are designed for reliable, accurate and trouble free operation. The meters are suitable for use with engine oil, gearbox oil, transmission fluid and premix coolants and have an accuracy of +/- 0.5% of reading.



DIGITAL OIL METER 1/2" 1500PSI L-DOM35-01

Heavy duty construction
Makes it suitable to use
on a wide range of pumps



Accurate digital meter
Can be set to display in
litres, gallons, pints &
quarts.

DIGITAL OIL METER 1/2" 725PSI L-DOM35-02

Heavy duty construction
Makes it suitable to use
on a wide range of pumps



Accurate digital meter
High accuracy digital oil
meter 5 digit easy to read,
resettable LCD display.

DIGITAL OIL METER 3/4" 725PSI L-DOM80-01

Heavy duty construction
Makes it suitable to use
on a wide range of pumps



Accurate digital meter
High accuracy digital oil
meter 5 digit easy to read,
resettable LCD display.

Part Number	L-DOM35-01	L-DOM35-02	L-DOM80-01
Description	DIGITAL OIL METER - 1/2" (1,500PSI)	DIGITAL OIL METER - 1/2" (725PSI)	DIGITAL OIL METER - 3/4" (725PSI)
Max pressure	1,500psi (10,000kPa)	725psi (5,000kPa)	725psi (5,000kPa)
Inlet port	1/2"	1/2"	3/4"
Thread	BSP (F)	BSP (F)	BSP (F)
Flow range	1 - 35L/min (9gal/min)	1 - 35L/min (9gal/min)	6-80L/min (1½ - 21gal/min)
Meter / register	Digital Oval Gear Meter	Digital Oval Gear Meter	Digital Oval Gear Meter
Accuracy	+/- 0.5%)	+/- 0.5%)	+/- 0.5%)
Compatible fluids	Suitable for oils up to SAE140, engine oils, gear oils, ATF, hydraulic oils and premixed coolants		

APPLICATIONS: Suitable for all oil dispensing application

Recommended to
be used with:

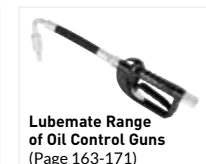

WASTE OIL EQUIPMENT

The 6L Pneumatic and Manual Oil Extractor is a 2 in 1 system which can be used to extract oil either pneumatically with the use of an air compressor or through manual operation by pumping the handle. The Package includes 3 different suction probes to extract oil. Ideal for extracting engine or transmission oils from cars, motorcycles, boats, jet ski, lawn mowers, ATV and static machines. Can also be used with water based fluids.



WASTE OIL EXTRACTOR PNEUMATIC & MANUAL L-OE6PM

**Quick and easy fluid extraction using
Pneumatic or Manual
Operation**

Large polypropylene tank
Designed to hold up to 6L of oil at tem-
peratures of 100°C

Integrated pressure relief switch
For safe pressure release

Three probes
For fluid removal through oil fill tube

Includes Footstep
For stability



Easy pour top spout
For easy disposal

Muffler
For gas and vapor dissipation
under compression

MANUAL WASTE OIL EXTRACTOR L-OE6



APPLICATIONS:
Suitable for mobile waste
oil evacuation

Part Number	L-OE6PM	L-OE6
Description	WASTE OIL EXTRACTOR PNEUMATIC & MANUAL	MANUAL WASTE OIL EXTRACTOR
Tank Capacity	6L	6.5L
Draining Oil Speed	1.8-2 L/min using probes	1.8-2 L/min using probes
Suction Probes	3 types	3 types
Max Oil Temperature	100°C (212°F)	100°C (212°F)
Height	648mm (2.1ft)	648 mm (2.1ft)
Working Pressure	90psi	N/a
Air Inlet Size	1/4" NPT	N/a
Compatible Fluids	Suitable for extracting engine or transmission oils from cars, motorcycles, boats, jet ski, lawn mowers, ATV and static machines. Can also be used with water based fluids.	Suitable for extracting all types of engine oils, transmission fluids, lubricants, from motor cars, motor bikes, marine engines, stationary engines, large and small industrial machinery, as well as non lubricants such as water from fish tanks, etc.

The Mobile Waste Oil Drainers from Lubemate are versatile, with a swivel extension arm that can extend to drain diff & transmission fluids into their 90L powder coated steel tank. The addition of the heavy duty, polyurethane wheels make it easier to move around the workshop.



GRAVITY WASTE OIL DRAINER 90L L-OD90B

Filter Mesh Screen In Bowl
Catch foreign items

Telescopic Suction Tube
Easy height adjustment

Powder Coated Steel Tank
90L capacity

Polyurethane Wheels
Easier manoeuvring over workshop floors



Wide Bowl Extender
Large enough for automatic transmission draining

Offset Swivelling Bowl
For easy bowl positioning

VACUUM/ GRAVITY WASTE OIL DRAINER 90L L-OD90



APPLICATIONS:
Suitable for mobile waste oil evacuation

COMPATIBLE FLUIDS
Suitable for draining all automotive oils from engines, gear box/transmissions and differentials

Part Number	L-OD90B	L-OD90
Description	GRAVITY WASTE OIL DRAINER 90L	VACUUM/ GRAVITY WASTE OIL DRAINER
Tank Capacity	90L (24gal)	90L (24gal)
Max drainer capacity	90L (24gal)	90L (24gal)
Oil draining pressure	1 bar	1 bar
Draining oil speed	N/A	1.8 - 3 L/min using probes
Suction probes	N/A	5 types
Length of oil release pipe	1.6m	1.6m
Without Extender Bowl	Max height : 1.95m (6.4ft) Min height : 1.21m (4ft)	Max height : 1.95m (6.4ft) Min height : 1.21m (4ft)
With Extender Bowl	Max Height : 2.05m (6.7ft) Min Height : 1.31m (4.3ft)	Max Height : 2.05m (6.7ft) Min Height : 1.31m (4.3ft)
Oil Bowl diameter	400mm - extends to 600mm with bowl extender	400mm - extends to 600mm with bowl extender
Offset Swivelling bowl diameter	Up to 800mm	Up to 800mm
Max oil temperature	120°C (248°F)	120°C (248°F)

TRUCK WASTE OIL DRAINERS

Truck Waste Oil Drainers from Lubemate come in two sizes to meet your heavy workshop needs. The premium L-TOD110P is rated up to 110L and its smaller brother the L-TOD95 at 95L is smaller yet agile to maneuverer. Suitable for the draining of waste oils and antifreeze from trucks and passenger cars.



TRUCK WASTE OIL DRAINER (110L) L-TOD110P

4 Wheel trolley design
Sturdy yet easy to move

Large Catchment Area
Minimise workshop floor spills

Easy Access Drain Plug
Quick evacuation
by pump or gravity



TRUCK WASTE OIL DRAINER (95L) L-TOD95

4 Wheel trolley design
Sturdy yet easy to move

Large Catchment Area
Minimise workshop floor spills

Easy Access Drain Plug
Quick evacuation
by pump or gravity

- Low level oil drainer with swivel castors for easy movement
- Anti-splash screen which can be used as a support for draining oil filters
- Solid steel construction

Part Number	L-TOD110P	L-TOD95
Description	TRUCK WASTE OIL DRAINERS (110L)	TRUCK WASTE OIL DRAINERS (95L)
Capacity	110L	95L
Drain valve	1/2"	1/2"
Anti-splash screen	✓	✓
4 wheel trolley design	✓	✓
Compatible fluids	Suitable for waste motor oil, gear oil, differential oil and antifreeze from trucks, buses, tractors, earthmoving/civil equipments and passenger cars	

OIL ACCESSORIES

12
MONTH
MACNAUGHT
WARRANTY*



**RIGID EXTENSION
MANUAL NOZZLE - 1/2"**

L-REXM

- Suited for use with most oil control guns
- Rigid tube with manual nozzle 1/2" BSP (M) inlet



**FLEXIBLE EXTENSION
AUTOMATIC
NOZZLE - 1/2" L-FEXA**

- Suited for use with most oil control guns
- Flexible hose 95° with automatic nozzle
- 1/2" BSP (M) inlet



**OIL CAN - 300ML
L-OC300**

- 300ml Oil Can with steel self-priming pump
- Rigid extension & flexible spout supplied



**DRUM WRENCH
ALUMINIUM 2" - 3/4" L-DWA**

- Used for 2" and 3/4" drum plugs



**ANTI-SPILL FUNNEL 1.7L
L-ASFS**

**ANTI-SPILL FUNNEL 3L
L-ASFL**

- Anti-splash & spill proof
- Wire mesh screen, dust cover & flexible spout
- L-ASFS:** 1.7L Plastic funnel with 20mm flexible spout
- L-ASFL:** 3L plastic funnel with flexible spout and 240mm in diameter. Can be mounted direct onto drums with 2" threaded opening drums



**PLASTIC MEASURING
JUG**

L-J2L, L-J5L, L-J6L, L-J8L

- Available in 2L, 5L, 6L and 8L variants
- Plastic measuring jug with flexible spout



**205L DRUM DOLLY
L-DT205**

- Suitable for 205L or 180Kgs drums
- Heavy duty construction fitted with robust castors
- Carefully wheel around 360 degrees



**DRUM TROLLEY
L-DT2060**

- Suitable for use with both 60L (16gal) & 20L (5gal) drums
- Allows easy movement of drum and pump around workshops



**TOP-UP PUMP-1L
L-TUP1L**

- 1L bottle suitable for lubricating oils & other service fluids
- Flexible delivery hose and nozzle with drain back
- 100ml graduations for easy measuring
- Large label for product identification



**UNIVERSAL CLAMPING
FUNNEL L-UCFL**

- Piercing attachment for easy bottle opening
- Clear funnel neck shows oil flow and helps prevent overfilling
- Nylon plier: Spring loaded clamp for easy single handed operation
- Suitable for use with Light, medium and high viscosity oils, diesel, detergents and gasoline



**WALL MOUNT DRIP
TRAY L-WMDT**

- Controls and collects oil drips
- Modular design suits any workshop
- Easily removed catchment tray for emptying and cleaning
- OH&S friendly
- Dimensions: 704mm (H) x 214mm (W) x 81.5mm (D) (165mm (D) inclusive of drip tray)



**2" DRUM FAUCET
WITH SIGHT GLASS
L-DTP2**

- Lockable valve
- Sight glass port to show level of fluid
- Container suitability: Fits into 2" threaded opening on 205L (55 gal) drums
- Polyethylene build
- Suitable for use with Engine oils, gear oils, light fuel oil, antifreeze, and light chemicals

MANUAL FUEL PUMPS



BI-LOBE PUMP L-BLPH

High performance diesel pump
Will pump in both directions

Impeller and gear design
Design allows fast fuel delivery

Strainer
60 mesh strainer

Delivery hose
2m x 1" i.d.



BI-LOBE FUEL PUMP with Meter and fittings L-BLPHFM

HA1S-01 filter, L-FM25 meter and DH-01 fittings included



BI-LOBE FUEL PUMP with Filter L-BLPH-KIT

HA-01 filter included



APPLICATIONS: Ideal for all fast flow diesel transfer applications

Part Number	L-BLPH	L-BLPHFM	L-BLPH-KIT
Description	BI-LOBE FUEL PUMP	BI-LOBE FUEL PUMP WITH FILTER & METER	BI-LOBE FUEL PUMP KIT WITH FUEL FILTER
Pump output	100L/min (26gal/min) (1ltr per rev)	100L/min (26gal/min) (1ltr per rev)	100L/min (26gal/min) (1ltr per rev)
Drum size	60-205L (16-54gal)		
Compatible fluids	Suitable for diesel, kerosene and light oils up to SAE30. Not suitable for petrol	Suitable for diesel & kerosene. Not suitable for oils	Suitable for diesel & kerosene. Not suitable for oils
Discharge Spout	2m (6.5ft) x 25mm (1") i.d. delivery hose with nozzle	2m (6.5ft) x 25mm (1") i.d. delivery hose with nozzle	2m (6.5ft) x 25mm (1") i.d. delivery hose with nozzle
Wetted Components	Aluminium, Steel, Nitrile	Aluminium, Steel, Nitrile	Aluminium, Steel, Nitrile
Filter	N/A	HA1S-01	HA-01
Meter	N/A	L-FM25	N/A
Fittings	N/A	DH-01	N/A

Recommended to be used with:

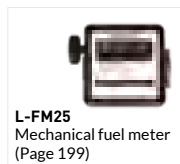

ROTARY VANE PUMP WITH HOSE
L-RPH

Strong cast iron construction
Reliable oil delivery

Dual Directional Operation
Allows the pump to both empty, as well as refill containers

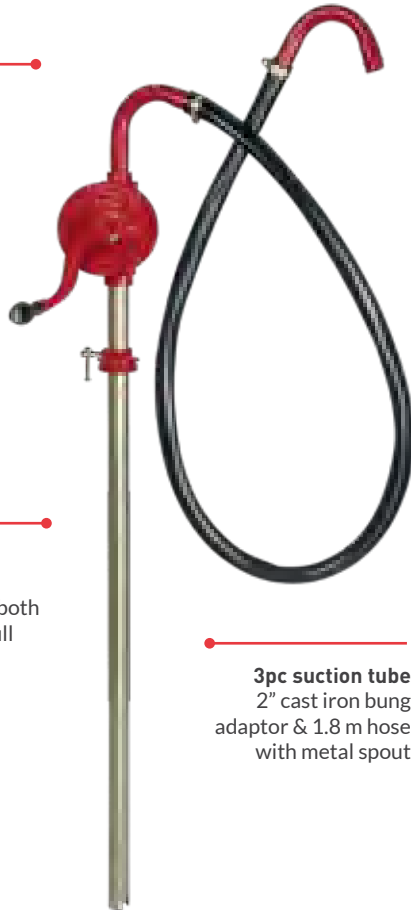

3pc suction tube
2" cast iron bung adaptor & 1.8 m hose with metal spout

PLASTIC SYPHON DRUM PUMP
L-PSP



Discharge Tube
Flexible corrugated

All pumps are equipped with a vent cap on top
Opening the cap stops discharge

Polyethylene Siphon Pump
For easy extraction of fluid

Easy to prime and start
Within 6-7 strokes

Pumps must never be used with hot media
At temperatures above 60°C (140°F)



Part Number	L-RPH	L-PSP
Description	ROTARY VANE FUEL PUMP WITH HOSE	PLASTIC SYPHON DRUM PUMP
Pump output	20L/min (5gal/min) (250ml per rev)	21L/min
Drum size	60-205L (16-54gal)	205L
Compatible fluids	Suitable for diesel, kerosene and mineral oils up to SAE90. Not suitable for petrol.	Water-based fluids, detergents, waxes, soaps, antifreeze, some mild acids, and other liquids compatible with pump construction materials. Not suitable for petrol.
Discharge Spout	1.8m (6ft) hose & metal nozzle	Flexible corrugated discharge tube
Wetted Components	Steel, Cast Iron, NBR	Polyethylene & Polypropylene
Filter	N/A	N/A

APPLICATIONS: Suitable for use across all industries

BATTERY OPERATED DRUM PUMPS

This innovative 19.2V Battery Drum Pump offers the portable design and the power of Lithium Ion battery technology. Transferring bulk liquids including Urea/DEF, water, diesel and coolants from multiple locations, or remote sites, is made easier. The compact, cordless and lightweight design features a telescopic suction tube suitable for use with both 205L drums and IBC systems.



19.2V RECHARGEABLE BATTERY DRUM PUMP L-BDP205L



Stainless steel filter

Built into the suction tube inlet prevents contaminants from getting in & causing damage

Telescopic suction tube

Extends from 33-1/2" (850 mm) to 49" (1245 mm) for use with 205 litre (55 gallon)

Hose and Nozzle

2m (6.6") hose & manual dispensing nozzle with 3/4" (19 mm) OD Stainless Steel Spout

Quiet motor

Makes almost no noise

Duty Cycle

15 minutes ON / 15 Minutes OFF

Li-Ion Battery 19.2V (1.5Ah)

Additional Bung Adaptor

Built in 2" drum thread & additional 2" IBC bung adaptor

Part Number	L-BDP205L
Description	19.2V RECHARGEABLE BATTERY DRUM PUMP
Pump output	Up to 28L/min (7gal/min)
Drum size	IBC or 205L (54gal) drums
Compatible fluids	Suitable for diesel, UREA/DEF, water, kerosene, antifreeze, windshield washer fluid, mild detergents, agricultural chemicals and light oils up to SAE10 *Not suitable for petrol
Wetted Components	Viton, POM, Stainless Steel, PE, NBR, PP

APPLICATIONS: Automotive, Truck and Buses, Farming, Manufacturing, Construction and Earthmoving

SPARE PARTS:

- L-DPCLI: Lithium-Ion charger
- L-DPBLI: Lithium-Ion battery

BATTERY OPERATED PLASTIC PUMP
L-BOP-5



Self priming pump

With 3V DC motor, requires (2x "D" size alkaline batteries) not included

Smooth Operation

Pump is operated by pressing the actuation button located on top



Hose

23-1/2" (600 mm) long flexible corrugated discharge hose

Applications

Ideal for transferring small quantities of media into boats, garages & small shop

Part Number	L-BOP-5
Description	BATTERY OPERATED PLASTIC PUMP
Pump output	7L/min (1.8gal/min)
Drum size	20L (5gal)
Compatible fluids	Suitable for transfer of diesel, kerosene, light oils up to SAE10 and water *Not suitable for ULP (petrol)
Wetted Components	Polypropylene, Polyethylene, NBR, SS, PVC & Acetal

APPLICATIONS: Automotive, Truck and Buses, Farming, Manufacturing, Construction and Earthmoving

SPARE PARTS:

- **L-DPCLI:** Lithium-Ion charger
- **L-DPBLI:** Lithium-Ion battery

ELECTRIC FUEL PUMPS



General purpose 12V Diesel Pump Kits available in automatic and manual configurations. These pumps are self-priming rotary vane pumps with a 30 minute duty cycle. It's a package that delivers convenience and peace of mind.



L-FPA12V

Automatic or manual nozzles available
Options available to suit different conditions

Mounting design
For use in confined spaces

Power Cable
2m power cable with alligator clips

Quality 12 volt diesel pumps
Reliable efficient design

Self-priming
Vane pump design and IP55 Protection

Portable Pump
Portable Diesel Transfer Pump with carry handle



L-FPM12V

Part Number	L-FPA12V	L-FPM12V
Description	"12V DIESEL PUMP KIT (Auto Nozzle)"	"12V DIESEL PUMP KIT (Manual Nozzle)"
Flow range	40L/min (11gal/min)	
Voltage	12V DC	
Duty cycle	30min ON/OFF	
Inlet/Outlet	3/4" BSP(F)	
Fuse	25A	
Nozzle	Automatic	Manual
Delivery / Suction Hose	19mm (3/4") x 4m (13ft) (cut to suit length)	
Suitable fluids	Suitable for diesel/ kerosene use only	
Package includes	Supplied with 12V pump unit, 2m power cable with alligator clips, delivery/suction hose (cut to suit length), delivery nozzle and fittings	

APPLICATIONS: Designed for use in agricultural, construction, automotive and industrial applications

Recommended to be used with:

<p>HA15-01 Fuel filter assembly (Page 100)</p>	<p>L-FM25 Mechanical fuel meter (Page 185)</p>	<p>L-DTFM Digital fuel filter (Page 185)</p>	<p>LH2510N Diesel delivery hose (Page 189)</p>	<p>L-FNADP Auto Diesel nozzle (Page 187)</p>	<p>L-FNMND Manual Diesel Nozzle (Page 187)</p>
---	---	---	---	---	---

General purpose 12V Diesel Pump Kits available in automatic and manual configurations. These pumps are self-priming rotary vane pumps with a 30 minute duty cycle. It's a package that delivers convenience and peace of mind.



L-HFFPA12V

Automatic or manual nozzles available
Options available to suit different conditions

Mounting design
For use in confined spaces

Power Cable
2m power cable with alligator clips

Quality 12 volt diesel pumps
Reliable efficient design

Self-priming
Vane pump design and IP55 Protection

Portable Pump
Portable Diesel Transfer Pump with carry handle



L-HFFPM12V

Part Number	L-HFFPA12V	L-HFFPM12V
Description	12V HIGH FLOW DIESEL PUMP KIT (Auto Nozzle)	12V HIGH FLOW DIESEL PUMP KIT (Manual Nozzle)
Flow range	56L/min (15gal/min)	
Voltage	12V DC	
Duty cycle	30min ON/OFF	
Inlet/Outlet	1" BSP(F)	
Fuse	40A	
Nozzle	Automatic	Manual
Delivery / Suction Hose	19mm (3/4") x 4m (13ft) (cut to suit length)	
Suitable fluids	Suitable for diesel/ kerosene use only	
Package includes	Supplied with 12V pump unit, 2m power cable with alligator clips, delivery/suction hose (cut to suit length), delivery nozzle and fittings	

*Note: pump not sold separately

APPLICATIONS: Designed for use in agricultural, construction, automotive and industrial applications

Recommended to be used with:



ELECTRIC FUEL PUMPS

The 240V Mini Bowser is the complete package for safe economical diesel delivery. The pump delivers up to 80L/min free flow, with built in meter and auto nozzle. There is also a built in switch that turns the pump off when the nozzle is replaced into the holder.



Resettable totaliser
4-digit resettable

Non-resettable totaliser
8-digit non-resettable

Bowser on/off switch
Pump protection from overheating

Hose restraint
Allows for neat hose storage

240V AUTO MINI BOWSER PUMP ASSY WITH AUTO NOZZLE L-HMBA240V

- A compact & convenient system designed for all stationary diesel refilling applications
- Extremely versatile, the bowser can be installed directly on a wall, on an existing structure with screws or directly on a tank
- Self priming, vane pump with an internal bypass valve is equipped with a self ventilated, 450W motor with thermal overload protection for continuous usage
- 240V AC pump unit
- Smart on/off switch built in at the bottom of nozzle restraint
- Nutating disc mechanical flow meter with 4-digit resettable totaliser and 8-digit non resettable totaliser
- 1.5m power cable with 10A plug
- 2m Suction hose with strainer
- Nozzle Holder In-built into the metal casing for keeping hose safe when not in use
- 4m delivery hose and auto nozzle equipped with a swivel at the inlet for convenience in usage
- All enclosed in a sturdy weather proof metal housing (IP55 protection)

Part Number	L-HMBA240V
Description	240V AUTO MINI-BOWSER PUMP ASSEMBLY WITH AUTO NOZZLE
Flow range	80L/min (21gal/min)
Voltage	240V AC
Duty cycle	Continuous
Inlet/Outlet	1" BSP(F)
Fuse	Thermal overload protection
Nozzle	Automatic
Suitable fluids	Suitable for diesel/ kerosene use only
Package includes	The kit contains, pump, flow meter, suction hose with strainer, 4m delivery hose and automatic nozzle

APPLICATIONS: Suitable for use across all industries for accurate high volume diesel delivery

Recommended to be used with:



FUEL METERS

DIGITAL METERS

Compact reliable turbine meters are designed for use in gravity and in line applications. Easy to read display with an accuracy up to +/- 1% of reading.

MECHANICAL METERS

Reliable & compact mechanical meter with large, easy to read digits. This unit features a nutating disc operation and field calibration adjustment capability to ensure accuracy.



DIGITAL DIESEL METER

L-DTFM (Diesel/Kerosene))

Tough Body

Poly Propylene body & sealed electronic card makes it suitable for use in severe weather conditions - IP55 protection

Digital Turbine meter

For low viscosity fluids, easy to install in line or for end of the line applications



Electronic Display
Using one 3V battery (CR2)

Easy Measurement
Measures in Litres, Quarts, Pints & Gallons and easy user re-calibration

MECHANICAL DIESEL METER

L-FM25

Tough Construction

Robust aluminum die cast construction makes it suitable for use in severe weather conditions

High Tolerance

Nutating disc mechanism offers high tolerance to fuel contamination

High accuracy

Diesel meter with large mechanical register which is easy to read



Applications
Meter is designed for both in-line applications & gravity flow (with a minimum gravity head of 4")

Part Number	L-DTFM	L-FM25
Description	DIGITAL DIESEL METER	MECHANICAL DIESEL METER
Max pressure	72psi (5bar)	49psi (3.5bar)
Inlet / Outlet	1"	1"
Thread	BSP (F)	BSP (F)
Flow range	10-100L/min (2.6-26gal/min)	20-120L/min (5-31gal/min)
Meter / register	Digital	Mechanical
Accuracy	+/- 1%	+/- 2%
Resettable totaliser	5	4
Non-resettable totaliser	7	8
Compatible fluids	Suitable for diesel and kerosene	Suitable for diesel and kerosene

Recommended to be used with:



FUEL NOZZLES

The new heavy duty Automatic Diesel Nozzle from Lubemate has been designed for diesel fuel delivery up to 60L/min. The premium nozzle comes standard with a stainless steel tip & auto shut-off nozzle to prevent overfilling. Comfortable to handle but built tough for application, the L-FNADP is your dependable Lubemate diesel dispenser. It is fitted with a positioning control device which allows the nozzle to shut-off when falling out of a vehicle; and if tipped up, limiting spillage and unsafe conditions.



DIESEL FUEL NOZZLE AUTOMATIC - PREMIUM L-FNADP

Tough & Ergonomic
Anti-slip handle for comfortable & safe operation

Position Control Device
Auto shut-off when displaced and tipped up

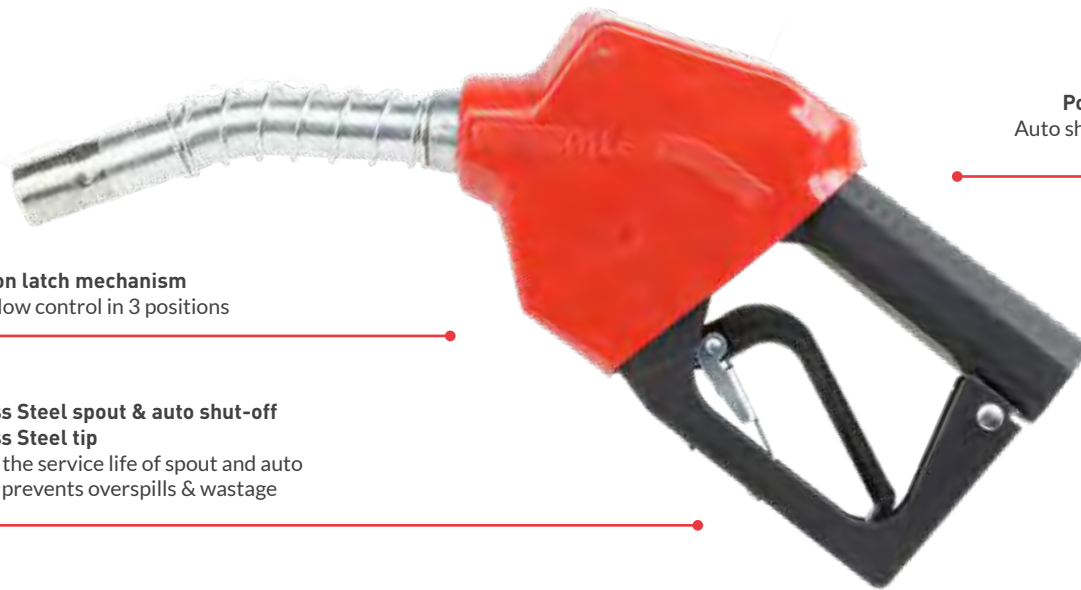

3 position latch mechanism
Allows flow control in 3 positions

Stainless Steel spout & auto shut-off
Stainless Steel tip
Extends the service life of spout and auto shut-off prevents overfills & wastage

Part Number	L-FNADP
Description	DIESEL FUEL NOZZLE AUTOMATIC - PREMIUM
Inlet	3/4" BSP (F)
Spout Diameter	15/16" o.d. spout
Flow rate	60L/min (16gal/min)
Type	Automatic shut-off
Compatible fluids	Diesel & Kerosene

*Automatic nozzles are not suitable for use in gravity applications

FEATURES AND BENEFITS

- Premium quality nozzles
- Diesel and ULP models available
- Suitable for use on most electric fuel pump types

APPLICATIONS: Automotive, Truck and Buses, Farming, Manufacturing, Construction and Earthmoving

Recommended to be used with:

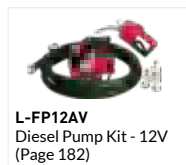



L-FNADP



L-FNAD



L-FNMD



MNHF-01



L-ANHF



L-FNAU

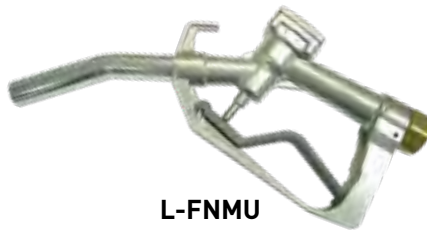

L-FNMU

APPLICATIONS: Automotive, Truck and Buses, Farming, Manufacturing, Construction and Earthmoving

Part Number	L-FNAD	L-ANHF	L-FNMD	MNHF-01	L-FNAU	L-FNMU
Description	FUEL NOZZLE AUTOMATIC - DIESEL	DIESEL NOZZLE AUTOMATIC - HI-FLO	FUEL NOZZLE MANUAL - DIESEL	DIESEL NOZZLE MANUAL - HI-FLO	FUEL NOZZLE AUTOMATIC - ULP	FUEL NOZZLE MANUAL - ULP
Inlet	3/4" BSP (F)	1" BSP (F)	1" BSP (F)	1 1/2" BSPP	3/4" BSP (F)	3/4" BSP (F)
Spout Diameter.	15/16" o.d. spout	1" o.d. spout	15/16" o.d. spout	1 5/8" o.d. spout	13/16" o.d. spout	13/16" o.d. spout
Flow rate	60L/min (16gal/min)	120L/min (31gal/min)	70L/min (18gal/min)	260L/min (68gal/min)	45L/min (12gal/min)	45L/min (12gal/min)
Type	Automatic shut-off	Automatic shut-off	Manual shut-off	Hi-Flo Manual	Automatic shut-off	Manual shut-off
Compatible fluids	Diesel & Kerosene	Diesel & Kerosene	Diesel & Kerosene	Diesel & Kerosene	Unleaded Petrol (Gasoline)	Unleaded Petrol (Gasoline)

*Automatic nozzles are not suitable for use in gravity applications

Recommended to be used with:



L-FS19
3/4" Swivel
(Page 189)



L-FS25
1" Swivel
(Page 189)



ASB1925
3/4" x 1" Swivel
(Page 189)



L-FP12AV
Diesel Pump Kit - 12V
(Page 182)



L-HFFPM12V High
Flow Diesel Pump Kit -
12V (Page 183)

AIR OPERATED DIAPHRAGM PUMPS

Ideal for dirty fluid transfer, these pumps provide continuous flow for use with waste and clean oil, diesel, engine coolant and water. Lightweight and easy to operate, these pumps are designed to provide continuous flow. These diaphragm pumps offer a great solution for clean and dirty liquids particularly waste oils as they are particle tolerant.



L-DDP13 (1/2")



L-DDP19 (3/4")

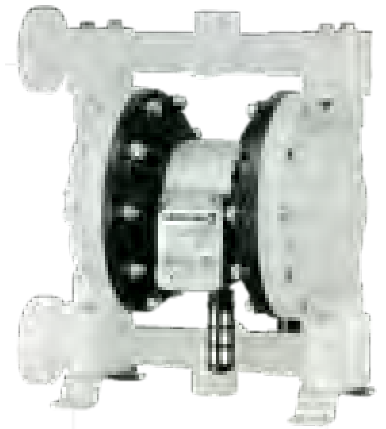

L-DDP25 (1")

Self priming

Allows for high suction lift even at dry start up and with heavier fluids

Ability to run dry

Pump can run dry without damage

Variable flow rate and discharge pressure

Pumps will run at any setting within their operating range simply by adjusting the air inlet pressure and system conditions

Portable /simple installation

Pumping efficiency remains constant

There are no rotors, gears, or pistons, which wear over time and lead to the gradual decline in performance and low rate.

APPLICATIONS: Ideal for the efficient transfer of diesel, new and waste oils, as well as most contaminated automotive fluids.

Part Number	L-DDP13	L-DDP19	L-DDP25
Description	AIR OPERATED DIAPHRAGM PUMP - 1/2"	AIR OPERATED DIAPHRAGM PUMP - 3/4"	AIR OPERATED DIAPHRAGM PUMP - 1"
Flow rate	45L/min (12gal/min)	60L/min (16gal/min)	90L/min (24gal/min)
Pump Inlet/Outlet	1/2" BSP (F)	3/4" BSP (F)	1" BSP (F)
Air Inlet		1/4" BSP	
Max air pressure		116psi (8bar)	
Max particle size		1/8" (3m) or less	
Wetted components		Polypropylene & NBR	
Operating Temp. Range		0°C (32°F) to +60°C (140°F)	
Suitable fluids	Suitable for waste and clean oil, diesel, engine coolant and water. Not suitable for flammable media (unleaded petrol)		

Recommended to be used with:

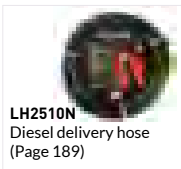

SERVICE PARTS:

- ▾ L-DDPSK1319 - Wet End Kit for L-DDP13 & L-DDP19
- ▾ L-DDPSK25 - Wet End Kit for L-DDP25
- ▾ L-DDPMK - Air Motor Service Kit for all L-DDP Models

FUEL ACCESSORIES



ANTI-STATIC FUEL HOSE - 1" x 4M LH254AS

- 1" x 4m i.d. Anti-static fuel delivery hose suitable for ULP and diesel fuel
- 1" BSP (M) crimped fittings
- Suitable for use with Gravity feed, Manual & Electric Fuel Pumps
- Excellent UV resistance & flexibility
- 6" strain relieving springs on hose ends
- Max working pressure: 145psi



DIESEL FUEL HOSE - 1" x 10m LH2510N

- 1" x 10m i.d. Diesel delivery UV stabilised hose
- Reinforced Nitrile rubber hose, diesel and oil resistant
- Suitable for suction and delivery of oils & diesel fuel only
- Operating temperature of -20°C to +80°C
- Max working pressure: 300psi



UNIVERSAL CLAMPING FUNNEL L-UCFL

- Piercing attachment for easy bottle opening
- Clear funnel neck shows oil flow and helps prevent overfilling
- Nylon plier: Spring loaded clamp for easy single handed operation
- Suitable for use with light, medium and high viscosity oils, diesel, detergents and gasoline



FUEL & OIL FUNNEL L-FOFL

- High flow fuel & oil funnel with extra large mouth for easy pouring
- Heavy duty polypropylene construction
- Spout dimensions: 1 - 3/4" (45mm), 1-1/8" (29mm)
- Tie hole built into the funnel for easy storage.
- Suitable for use with diesel, urea, and other water based media



PORTABLE FUEL FILTER FUNNEL L-PFFL

- Anti-static, heavy duty, fast-flow portable funnel
- Filter out free water and solids till 100 microns from fuel
- Vertical design of the filter permits free flow of fluids without exerting any pressure on the filter screen
- Suitable for use with diesel, gasoline, kerosene and light oils
- Teflon coated stainless steel filter element is virtually maintenance free



HOSE SWIVEL - 3/4" L-FS19

- Straight type swivel for fuel nozzles with 3/4" fluid inlet
- 3/4" BSP (M) x 3/4" BSP (F)



HOSE SWIVEL - 1" L-FS25

- Straight type swivel for fuel nozzles with 1" fluid inlet
- 1" BSP (M) x 1" BSP (F)



HOSE SWIVEL - 3/4" X 1" ASB1925

- Straight type swivel for fuel nozzles with 3/4" fluid inlet and 1" hose inlet.
- 3/4" BSPT (M) x 1" BSPT (F)

ADBLUE® AND SPECIALTY MANUAL PUMPS



ROTARY VANE PUMP (STAINLESS STEEL) L-SSRP

DRUM PUMP (STAINLESS STEEL) L-SSHP

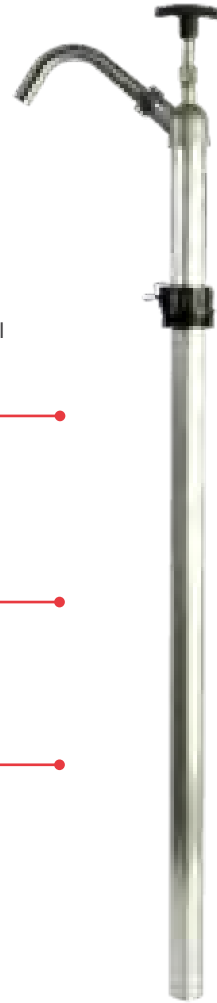
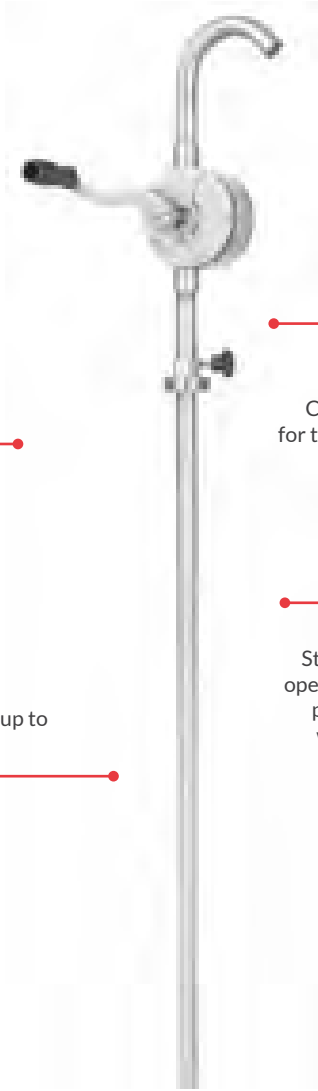

Self priming
Easy to use

Spout Outlet
With Flow rate up to
4L/20 turns

Stainless Steel construction
Corrosion resistant for transferring a wide variety of fluids

Superior quality
Stainless Steel hand operated rotary drum pump, constructed with 304 Stainless Steel body, bung adaptor & suction tube

Spare seals
An extra set of spare seals and flow control tubes included with each pump

Self priming
Easy to use

In-built lock nut
For attaching grounding wires

Strong Pump body
Made of 316 Stainless Steel, PTFE piston makes it suitable for use with wide variety of fluids (maximum temperature: 60°C)

2" Bung adaptor
Suitable for both metal and plastic drums

Part Number	L-SSRP	L-SSHP
Description	ROTARY VANE PUMP (Stainless Steel)	DRUM PUMP (Stainless Steel)
Pump output	20L/min (5gal/min)	600ml/stroke
Drum size	60-205L (16-54gal)	
Compatible fluids	Suitable for use with water based media, antifreeze, acids, chemicals, all petroleum based products, lacquer, thinner, UREA and DEF	Suitable for use with Photographic chemicals/solvents, diesel, kerosene, thinners, acetone, benzene, naptha, urea, DEF & light oils up to SAE 40
Discharge Spout	304 Stainless Steel	316 Stainless Steel
Wetted Components	304 Stainless Steel, PTFE, Viton®	316 Stainless Steel, PTFE

CHEMICAL ROTARY PUMP L-MACP200

Rotary Action

Allows delivery in both directions (reverse pumping requires removal of foot valve)



3 additional bung adaptors supplied :

1. Drum Adaptor (Orange) - 2" BSP(F) to 2"Tri-Sure (M)
2. Drum Adaptor (Yellow) - 2" BSP(F) to DIN61(F)
3. Drum Adaptor (Blue) - 2" BSP(F) to 2" Mauser (M)

3-piece suction tube
For easy use with 60L drums

PLASTIC SYPHON DRUM PUMP L-PSP



Discharge Tube
Flexible
corrugated

All pumps are equipped with a vent cap on top
Opening the cap stops discharge

Pumps must never be used with hot media
At temperatures above 60°C (140°F)

Polyethylene Siphon Pump
For easy extraction of fluid

Easy to prime and start
Within 6-7 strokes



Part Number	L-MACP200	L-PSP
Description	CHEMICAL ROTARY PUMP	PLASTIC SYPHON DRUM PUMP
Pump output	20L/min (5gal/min)	21L/min (5.5gal/min)
Drum size	60-205L (16-54gal)	205L (54gal)
Compatible fluids	Suitable for transferring mineral oils, acids, alkali, alcohols, diesel, coolants, water-based chemicals and clean or salt waters. AdBlue/DEF compatible	Water-based fluids, detergents, waxes, soaps, antifreeze, some mild acids, and other liquids compatible with pump construction materials
Discharge Spout	2m flexible delivery hose and nozzle	Flexible corrugated discharge tube
Wetted Components	Polypropylene body with PPS (Ryton®) rotors	Polyethylene & Polypropylene

* Note: Chemical compatibility chart included for L-MACP200

ADBLUE® NOZZLES

STAINLESS STEEL NOZZLE - ADBLUE®/DEF L-SSANM



Magnetic Tank Adaptor

To fit most common application inlets to prevent misfilling. Must be used with L-MTA (supplied)

Stainless Steel Nozzle with Auto shut-off
For heavy duty applications to prevent overfilling

3 position latch mechanism
Allows flow control in 3 positions

Detachable Stainless Steel Swivel
3/4" swivel hose tail inlet



POLY AUTOMATIC NOZZLE - ADBLUE®/DEF L-PAN



Automatic Nozzle
Prevent overspills & wastage

3 position latch mechanism
Allows flow control in 3 positions

3/4" Stainless Steel (304) hose tail
Heavy duty to suit 3/4" hose

Lightweight polypropylene body & stainless steel nozzle
Good balance of weight & strength

POLY MANUAL NOZZLE - ADBLUE®/DEF L-PMN



1" BSPP poly swivel
Fits most hose and pump assembly for easy swap out

Lightweight polypropylene body
High quality manual nozzle for both pump & gravity applications

Simple & basic design
Cost effective for low budget applications

Part Number	L-SSANM	L-PAN	L-PMN
Description	STAINLESS STEEL NOZZLE - ADBLUE®/DEF	POLY AUTOMATIC NOZZLE - ADBLUE®/DEF	POLY MANUAL NOZZLE - ADBLUE®/DEF
Swivel inlet	3/4"	3/4"	1"
Flow range	60L/min (16gal/min)	45L/min (12gal/min)	60L/min (16gal/min)
Construction	Stainless Steel (304)	Polypropylene/Stainless Steel (304)	Polypropylene
Type	Automatic shut-off	Automatic shut-off	Manual trigger
Spout	19mm (3/4")	19mm (3/4")	19mm (3/4")
Compatible fluids	Suitable UREA/AdBlue/DEF Fluids		
Product Inclusions	Stainless steel nozzle, L-MTA magnetic tank adaptor and L-SS19 3/4" swivel hose tail	Poly automatic nozzle and swivel (L-PASW)	Poly manual nozzle

Recommended to be used with:

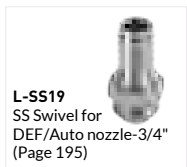

ADBLUE®/DEF ELECTRIC PUMPS

This unit is ideal for measured Urea/DEF dispensing. It is designed to be easily relocated between IBC, tanks or drums. It comes fully assembled with powder coated steel mounting plate, diaphragm pump, turbine meter and manual nozzle. The integrated Lubemate digital meter provides clear measurement of the flow rate and volume dispensed. Designed to transfer DEF from a Drum/Tote to smaller container/engines etc.

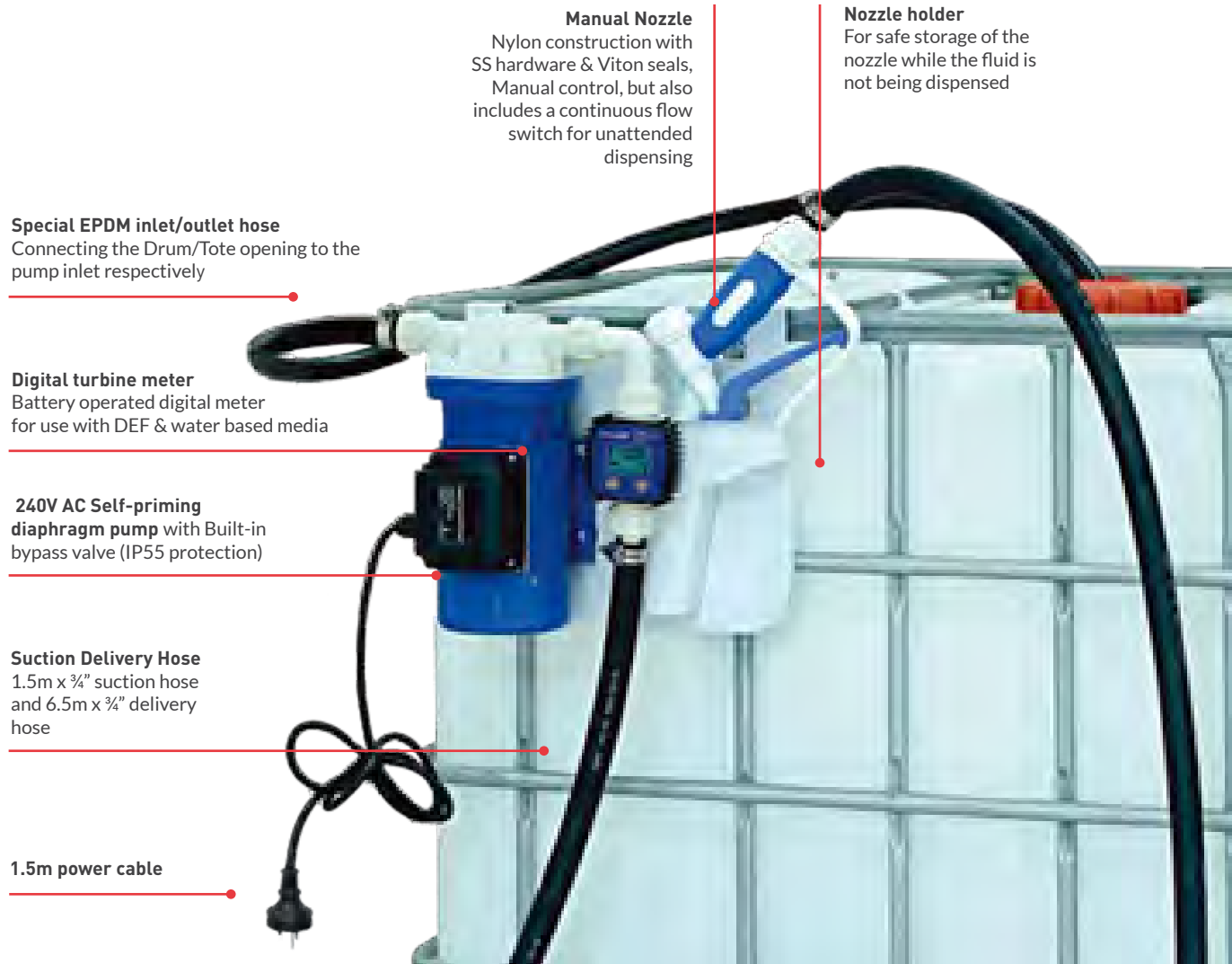

Manual Nozzle

Nylon construction with SS hardware & Viton seals, Manual control, but also includes a continuous flow switch for unattended dispensing

Nozzle holder

For safe storage of the nozzle while the fluid is not being dispensed

Special EPDM inlet/outlet hose

Connecting the Drum/Tote opening to the pump inlet respectively

Digital turbine meter

Battery operated digital meter for use with DEF & water based media

240V AC Self-priming diaphragm pump

with Built-in bypass valve (IP55 protection)

Suction Delivery Hose

1.5m x 3/4" suction hose and 6.5m x 3/4" delivery hose

1.5m power cable

Part Number	L-UPM240V
Description	240V ADBLUE®/DEF IBC TRANSFER KIT
Flow range	25L/min (6.6gal/min)
Voltage	240V AC
Duty cycle	Continuous
Inlet/Outlet	3/4" BSP(F)
Suitable fluids	Suitable for ADBLUE®/DEF and water
Package includes	Supplied with manual nozzle, delivery hose, power cable, suction hose and digital turbine meter on custom IBC mounting plate

Recommended to be used with:

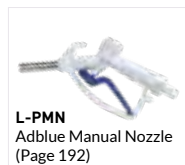

ADBLUE®/DEF METERS

DIGITAL ADBLUE®/DEF METER L-DTUM



Protection

Poly Propylene body & sealed electronic card makes it suitable for use in severe weather conditions (IP55 Protection)

Digital turbine meter

For low viscosity fluids, easy to install in line or for end of the line applications



Easy Measurement

Measures in litres, quarts, pints & gallons and easy user re-calibration

Electronic display

Using one 3V battery (CR2)

Part Number	L-DTUM
Description	DIGITAL ADBLUE®/DEF METER
Max pressure	72psi (5bar)
Inlet / Outlet	1"
Thread	BSP (F)
Flow range	10-100L/min (2.6-26gal/min)
Meter / register	Digital
Accuracy	+/- 1%
Resettable totaliser	5
Non-resettable totaliser	7
Compatible fluids	Suitable for ADBLUE®/DEF and water

ADBLUE® ACCESSORIES



ADBLUE® MAGNETIC TANK ADAPTOR

L-MTA

- Mis-filling prevention device for AdBlue®/DEF
- To suit AdBlue Automatic Nozzle (L-SSANM) with 19mm o.d. spout

EPDM UREA/DEF HOSE - 3/4" x 8M

LH198B

- Diameter: 19mm ID
- Material: EPDM rubber
- Wall thickness: 4mm
- Length: 8 metres
- Max pressure: 200psi
- Suitable for use with AdBlue®, DEFs, UREA/WATER



SS SWIVEL FOR POLY AUTO NOZZLE

L-PASW

- Swivel for DEF/AdBlue® Poly Automatic Nozzle
- Stainless Steel Swivel
- To suit AdBlue® Poly Auto Nozzle (L-PAN)

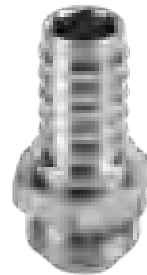

SS SWIVEL FOR DEF/AUTO NOZZLE - 3/4"

L-SS19

- Stainless steel (304) swivel for DEF/AdBlue® Automatic Nozzle
- 3/4" BSP (M)
- To suit AdBlue® Automatic Nozzle (L-SSANM)

METAL HOSE REELS

LS Series Single Pedestal Metal Hose Reels

The Lubemate L-S Series Single Pedestal hose reel has a robust, all-steel construction, reinforced with stamped ribs to provide exceptional strength and stability. The powder-coated, corrosion-resistant finish combined with an enclosed spring design, increases longevity in the reel's lifespan. The guide arm can be adjusted in different positions to accommodate various mounting structures and its narrow footprint allows for multiple reels to take up only minimal space. The Lubemate Single Pedestal hose reel offers a reliable & cost-effective solution to your workshop.



LS SERIES



Heavy duty steel frame
Designed for robust application

Corrosion resistant
Powder-coated body

Long-lasting spring
Fully enclosed and lubricated

Flexible positioning of guide arm
For mounting on bench, ceiling or wall

APPLICATIONS: Ideal for industrial and automotive field applications, such as car and truck dealerships, automotive workshops, and general manufacturing.

Part Number	L-AWS1015	L-AWS1215	L-OS1215	L-GS0615	L-GS1015
Description	Air/Water Hose Reel 10mm x 15m	Air/Water Hose Reel 12.5mm x 15m	Oil Hose Reel 12.5mm x 15m	Grease Hose Reel 6mm x 15m	Grease Hose Reel 10mm x 15m
Application	Air/Water	Air/Water	Oil	Grease	Grease
Hose Size (ID)	10mm (3/8")	12.5mm (1/2")	12.5mm (1/2")	6mm (1/4")	10mm (3/8")
Hose Length	15m	15m	15m	15m	15m
Hose Material	NBR rubber	NBR rubber	S.A.E. R1 wire braid	S.A.E. R2 wire braid	S.A.E. R2 wire braid
Working Pressure	290 psi	290 psi	2300 psi	5800 psi	5000 psi
Max Temperature	80° C	80° C	100° C	100° C	100° C
Reel Inlet	3/8" BSPT (F)	1/2" BSPT (F)	1/2" BSPT (F)	1/4" BSPT (F)	3/8" BSPT (F)
Hose Outlet	3/8" BSPT (M)	1/2" BSPT (M)	1/2" BSPT (M)	1/4" BSPT (M)	3/8" BSPT (M)

Recommended to
be used with:

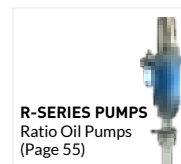
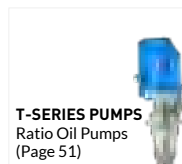

LT Series Twin Pedestal Metal Hose Reels

The Lubemate L-T Series Twin Pedestal hose reel has a robust, all-steel construction, reinforced with stamped ribs to provide exceptional strength and stability. The powder-coated, corrosion-resistant finish combined with an enclosed spring design, increases longevity in the reel's lifespan. The guide arm can be adjusted in different positions to accommodate various mounting structures. The Twin Pedestal design offers greater strength and stability by supporting the drum shaft on both sides.



LT
SERIES



Heavy duty steel frame
Designed for robust application

Corrosion resistant
Powder-coated body

Long-lasting spring
Fully enclosed and lubricated

Flexible positioning of guide arm
For mounting on bench, ceiling or wall

APPLICATIONS: Ideal for industrial and automotive field applications, such as car and truck dealerships, automotive workshops, and general manufacturing.

Part Number	L-AWTP1015	L-AWTP1215	L-OTP1215	L-GTP0615	L-GTP1015
Description	Air/Water Hose Reel 10mm x 15m	Air/Water Hose Reel 12.5mm x 15m	Oil Hose Reel 12.5mm x 15m	Grease Hose Reel 6mm x 15m	Grease Hose Reel 10mm x 15m
Application	Air/Water	Air/Water	Oil	Grease	Grease
Hose Size (ID)	10mm (3/8")	12.5mm (1/2")	12.5mm (1/2")	6mm (1/4")	10mm (3/8")
Hose Length	15m	15m	15m	15m	15m
Hose Material	NBR rubber	NBR rubber	S.A.E. R1 wire braid	S.A.E. R2 wire braid	S.A.E. R2 wire braid
Working Pressure	290 psi	290 psi	2300 psi	5800 psi	5000 psi
Max Temperature	80° C	80° C	100° C	100° C	100° C
Reel Inlet	3/8" BSPT (M)	1/2" BSPT (M)	1/2" BSPT (M)	1/4" BSPT (M)	3/8" BSPT (M)
Hose Outlet	3/8" BSPT (M)	1/2" BSPT (M)	1/2" BSPT (M)	1/4" BSPT (M)	3/8" BSPT (M)

Recommended to be used with:

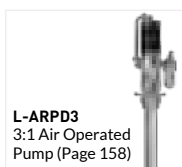

METAL HOSE REELS

LH Series Heavy Duty Metal Hose Reels

The Lubemate LH-Series Heavy Duty Hose Reels offer the greatest strength and stability in the Lubemate hose reel range. The all-steel construction is reinforced with stamped ribs and powder-coated to protect against corrosion to increase the lifespan of the reel. The reel drum size and the enclosed spring design allow for greater hose volume and comes standard with a guide arm that can be repositioned to suit all common heavy-duty applications.



LH SERIES



Heavy duty steel frame
Designed for robust application

Corrosion resistant
Powder-coated body

Long-lasting spring
Fully enclosed and lubricated

Flexible positioning of guide arm
For mounting on bench, ceiling or wall

APPLICATIONS: Ideal for industrial and automotive field applications, such as car and truck dealerships, automotive workshops, lube trucks, mass transit vehicles and general manufacturing.

Part Number	L-OTP1920	L-AWTP1920	L-DTP2515
Description	Oil Hose Reel 19mm x 20m	Air/Water Hose Reel 19mm x 20m	Oil Hose Reel 19mm x 20m
Application	Oil	Air/Water	Diesel/Air/Water
Hose Size (ID)	19mm (3/4")	19mm (3/4")	25mm (1")
Hose Length	20m	20m	15m
Hose Material	S.A.E. R1 wire braid	NBR rubber	NBR rubber
Working Pressure	1500 psi	290 psi	290 psi
Max Temperature	100° C	80° C	80° C
Reel Inlet	3/4" BSPT (F)	3/4" BSPT (F)	1" BSPT (F)
Hose Outlet	3/4" BSPT (M)	3/4" BSPT (M)	1" BSPT (M)

Recommended to be used with:

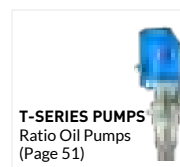
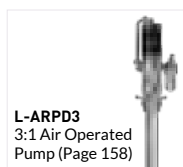

HOSE REELS

AIR/WATER REEL L-PAW1220 L-PAW1030



Positive hose latch
Locks your hose at any length

MINI AIR/WATER REEL L-PAW1014



Built-in hose layering mechanism
Hose rewinds safely with no bunching or kinks

DOMESTIC WATER REEL L-PDW1225



APPLICATIONS: The air water reels are the ideal choice for Automotive workshop applications. The domestic reel is suitable for horticultural or domestic garden use.

180° swivel bracket
The hose follows your direction as you move around

UV stabilised hose and case
The hose is ready for Australia's toughest environmental conditions

Part Number	L-PAW1220	L-PAW1030	L-PAW1014	L-PDW1225
Description	Air/Water Reel (12mm x 20M)	Air/Water Reel (10mm x 30M)	Mini Air/Water Reel	Domestic Water Reel
Working pressure	174psi (12bar)	174psi (12bar)	174psi (12bar)	87psi (6bar)
Hose Size	1/2"	3/8"	3/8"	1/2"
Hose length	20m (65ft)	30m (98ft)	14m (46ft)	25m (82ft)
Case material	UV stabilised Polypropylene	UV stabilised Polypropylene	UV stabilised Polypropylene	UV stabilised Polypropylene
Hose layering mechanism	✓	✓	✓	✓
Speed control mechanism	✓	✓	✗	✗
Inlet fitting	3/8" BSP(M)	1/4" BSP (M)	1/4" BSP (M)	Standard garden tap connection
Outlet fitting	3/8" BSP(M)	1/4" BSP (M)	1/4" BSP (M)	Garden tap connection with twist nozzle
Feeder hose	2m (included)	2m (included)	1m (included)	2m (included)
Positive Hose Latch	✓	✓	✓	✓
180° Swivel bracket	✓	✓	✓	✓
Suitable fluids	Compressed Air/Water	Compressed Air/Water	Compressed Air/Water	Water



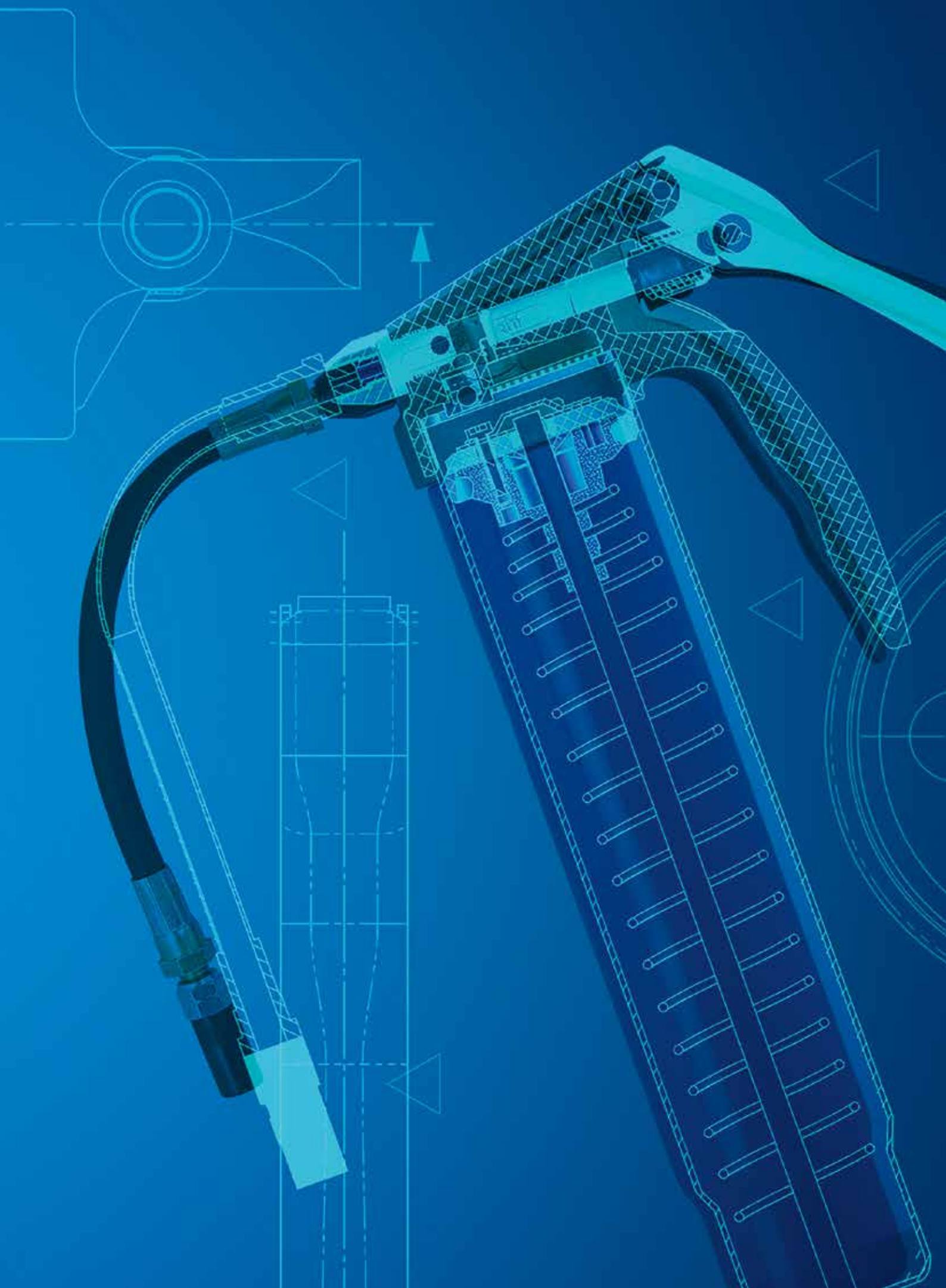

A technical drawing of a mechanical part, possibly a valve or a pump component, rendered in light blue lines on a dark blue background. The drawing shows a cross-section of a cylindrical component with a central vertical shaft and a circular base. A thick, curved blue line is overlaid on the left side of the drawing, suggesting a highlight or a specific part of the component.

SERVICEABLE PARTS

SERVICE PARTS

K29/K32 FLEXIGUN® EXPLODED DIAGRAM

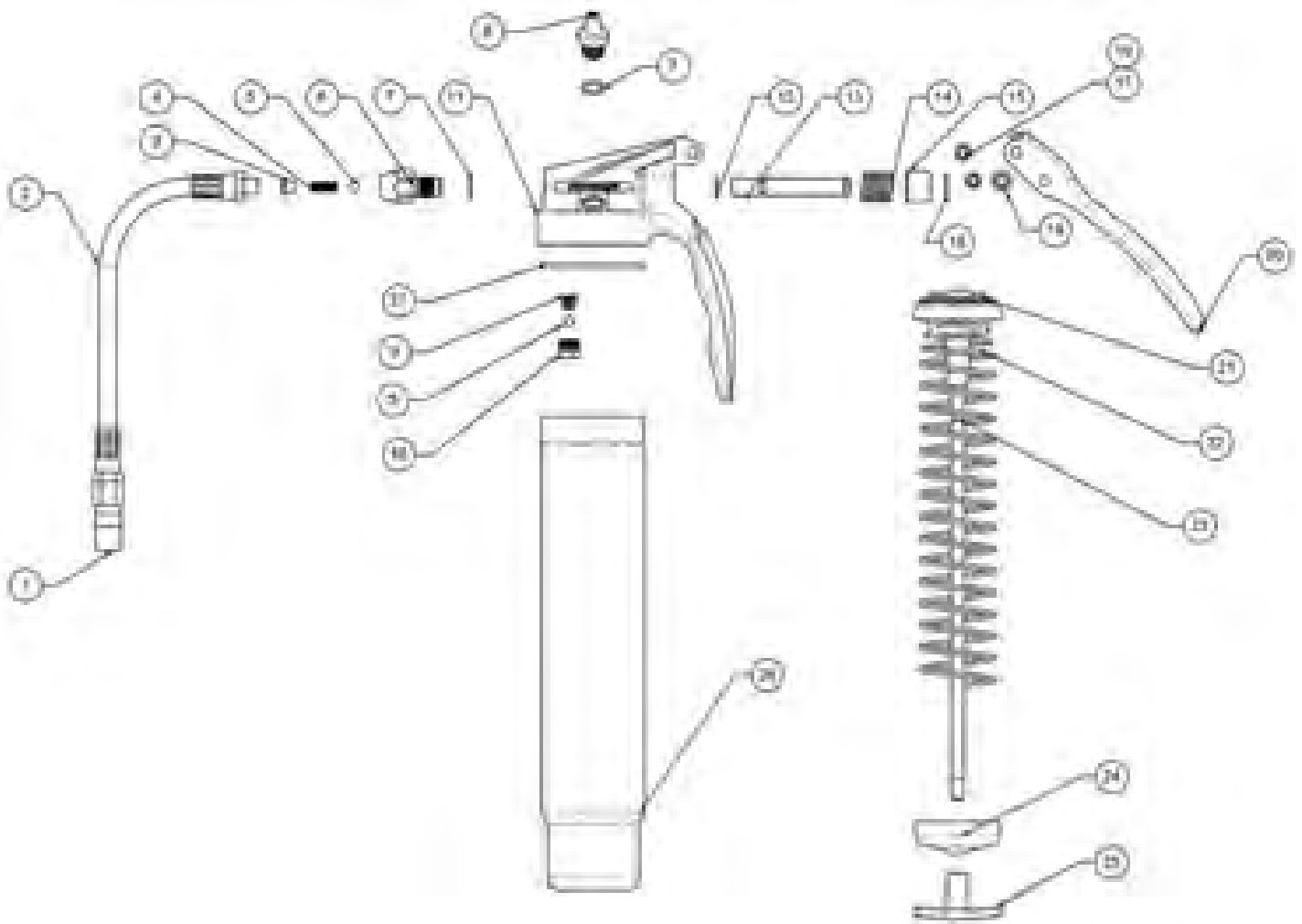

K29-01 FLEXIGUN®	
Kit Number	Includes Items
K29-1K service kit	3, 4, 5, 6, 7, 8, 9, 10, 11, 12, 13, 14, 15, 16, 17, 18, 19, 27
K27-2K follower kit	21, 27

K32-01 FLEXIGUN®	
Kit Number	Includes Items
K29-1K service kit	3, 4, 5, 6, 7, 8, 9, 10, 11, 12, 13, 14, 15, 16, 17, 18, 19, 27
KF14A-2K follower kit	21, 27

For more product information:



K29-01
(Page 15)



K32-01
(Page 15)

K45/K40 LEVERGUN® EXPLODED DIAGRAM

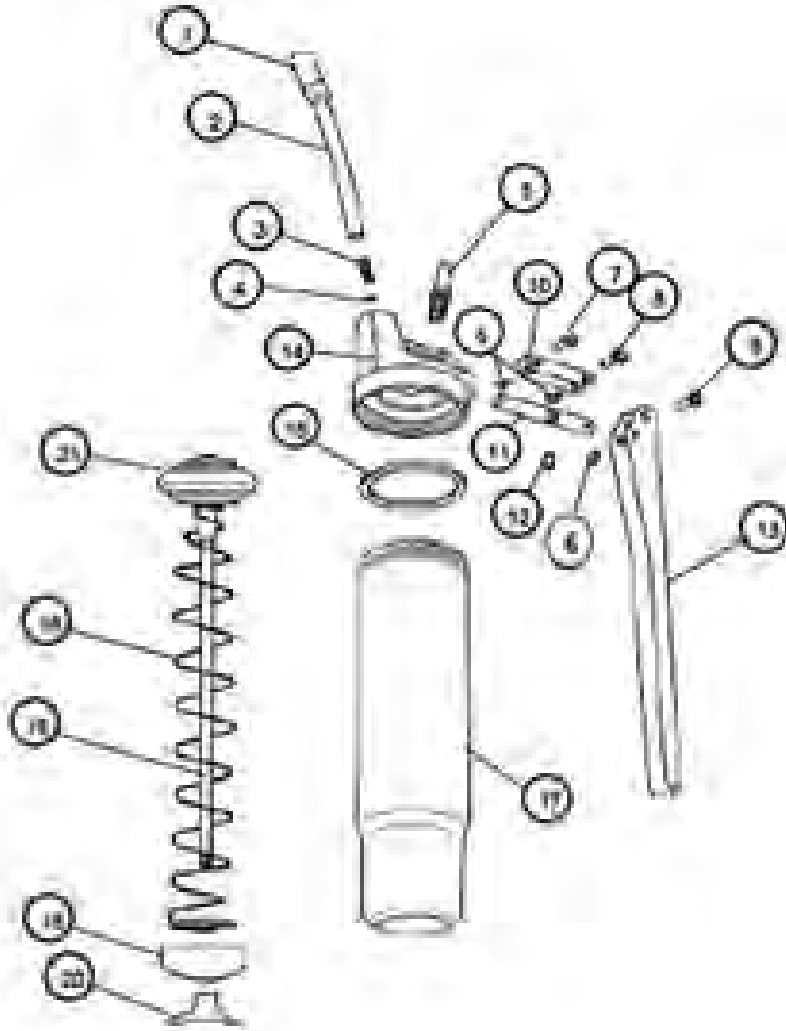

K45-01 LEVERGUN®

Kit Number	Includes Items
K45-1K service kit	3, 4, 5, 6, 7, 8, 9, 10, 11, 12, 15
KF27-2K follower kit	15, 21

K40-01 LEVERGUN®

Kit Number	Includes Items
K45-1K service kit	3, 4, 5, 6, 7, 8, 9, 10, 11, 12, 15
KF14A-2K follower kit	15, 21

For more product information:



SERVICE PARTS

K53 POWERPISTOL™ EXPLODED DIAGRAM

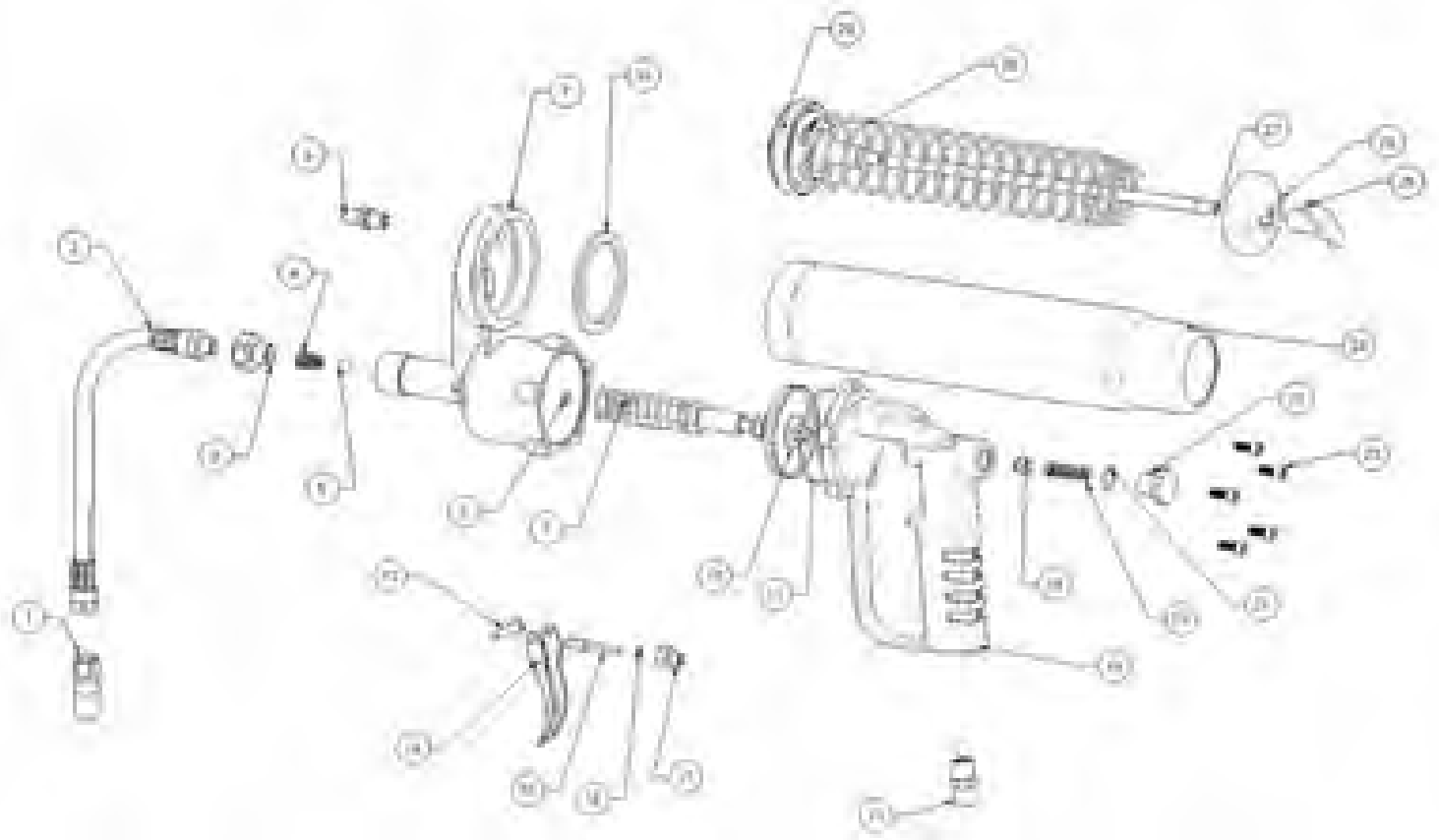

K53-01 POWERPISTOL™	
Kit Number	Includes Items
K53-1K service kit	3, 4, 5, 6, 8, 9, 10, 11, 12, 13, 14, 15, 16, 17, 19, 20, 21, 22
KF27-2K follower kit	29, 30

For more product information:



K53-01
(Page 17)

J3 BULK FILL PUMP EXPLODED DIAGRAM

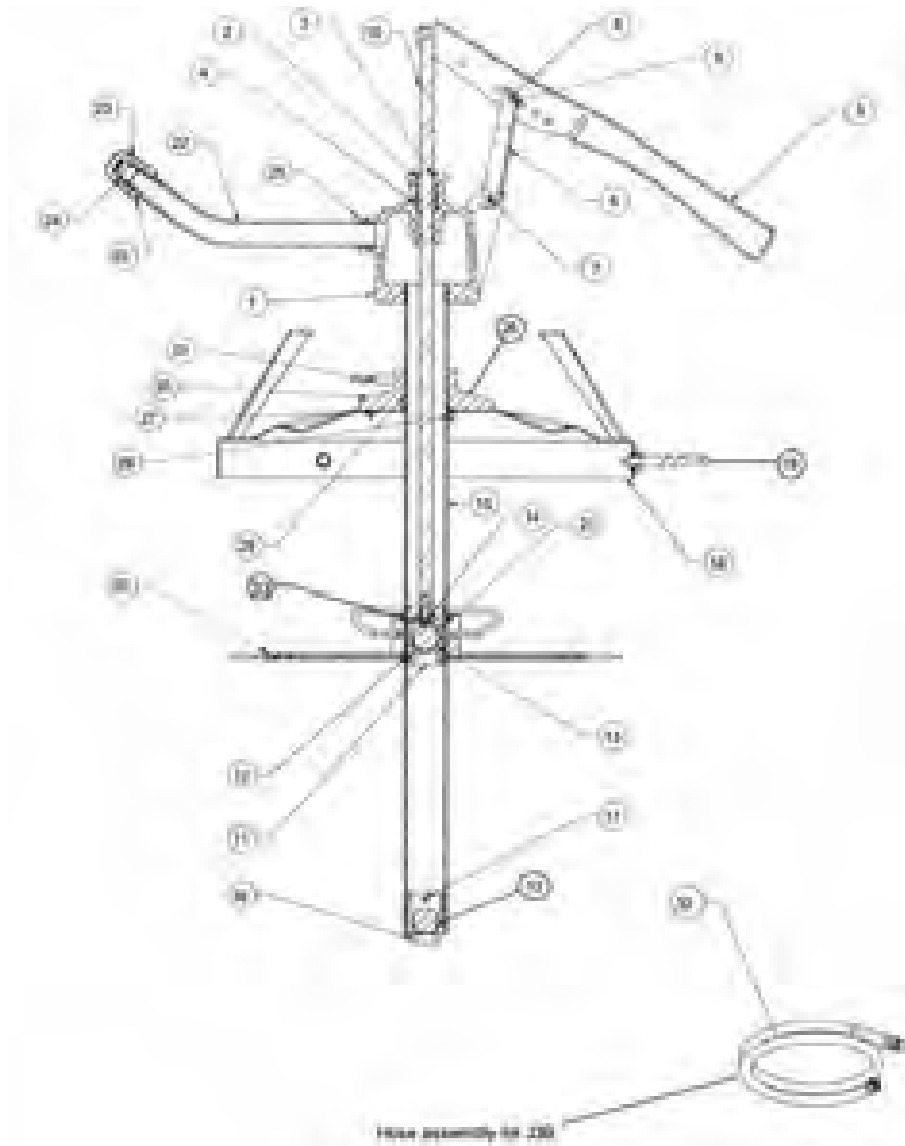

K45-01 LEVERGUN®

Kit Number	Includes Items
J3-1K service kit	2, 3, 4, 6, 7, 8, 9, 12, 13, 14, 19, 21, 24, 29
J3 hose assembly	J3-HOSE

For more product information:

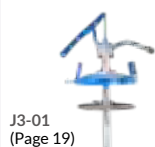

J3-01
(Page 19)

SERVICE PARTS

K4 MANUAL GREASING SYSTEM EXPLODED DIAGRAM

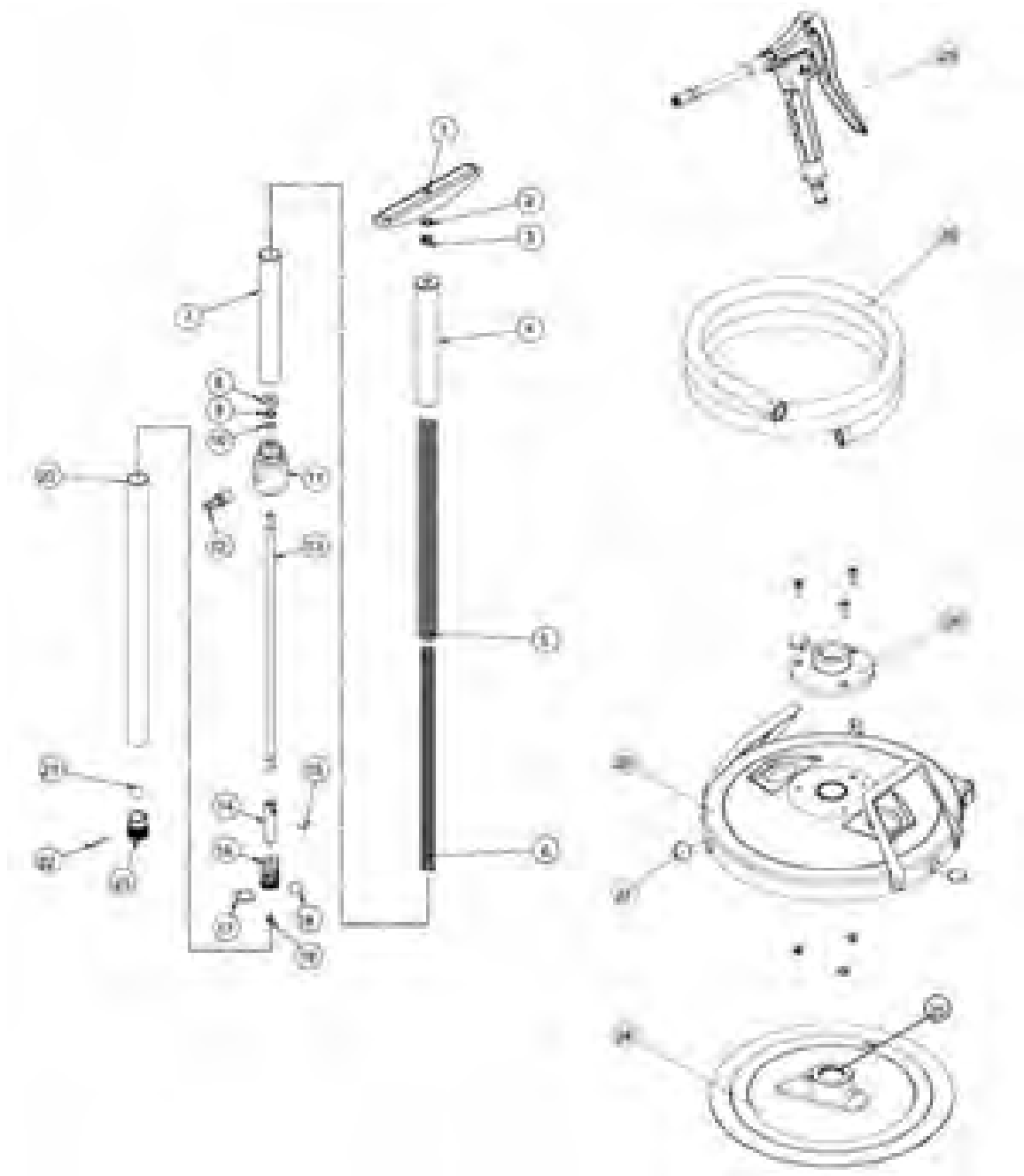

K4-01	
Kit Number	Includes Items
K4-1K Pump service kit	8, 9, 10, 15, 17, 18, 19, 21, 22, 23, 25, 27

For more product information:

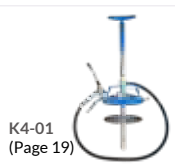

K7 MINILUBE® EXPLODED DIAGRAM

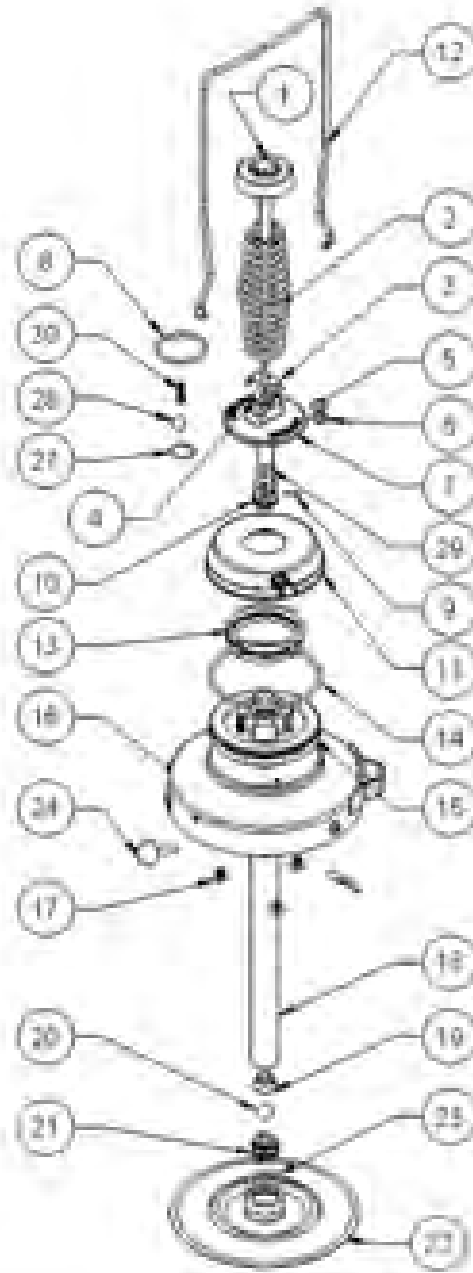

K7-01 MINILUBE®

Kit Number	Includes Items
K7-2K Pump unit assembly kit	1, 2, 3, 4, 5, 6, 7, 8, 9, 10, 11, 13, 14, 15, 27, 28, 29, 30
K7-3K Pump seal kit	5, 6, 8, 13, 14, 19, 20, 21, 23, 24, 27, 28, 30

For more product information:

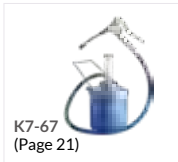

SERVICE PARTS

KR GREASE GUN EXPLODED DIAGRAM

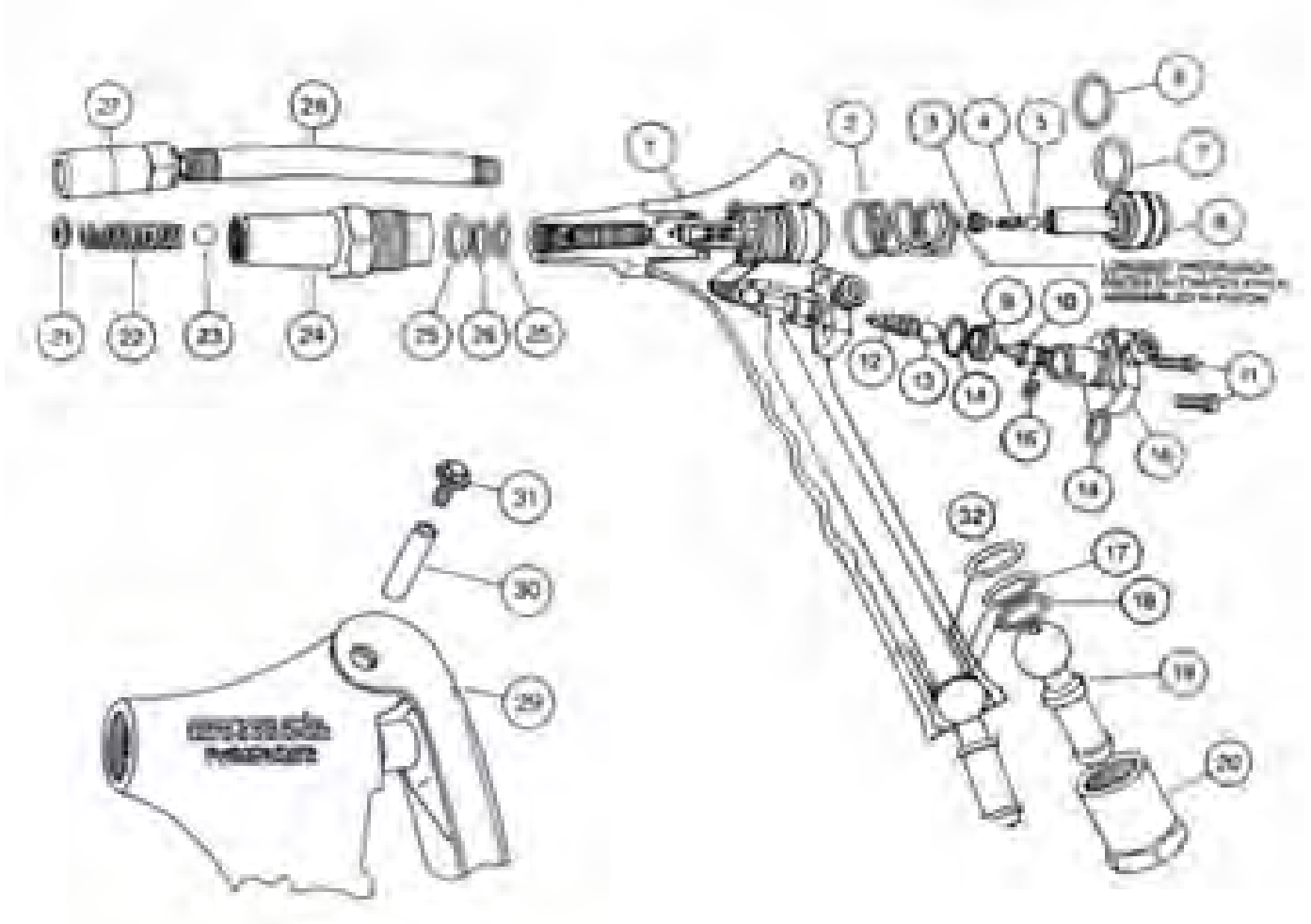

KR GREASE GUN	
Kit Number	Includes Items
KR-1K Gun overhaul kit	2, 3, 4, 5, 6, 7, 8, 9, 12, 13, 14, 15, 17, 18, 21, 22, 23, 25, 26, 30, 31, 32,
KR-2K Gun piston kit	2, 3, 4, 5, 6, 7, 8, 30, 31

For more product information:



KR
(Page 38)

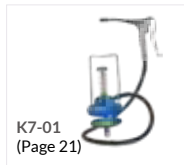

K7-01
(Page 21)



K7-24
(Page 21)



K7-67
(Page 21)

P3 / P6 / P8 SERIES AIR OPERATED PUMPS EXPLODED DIAGRAM

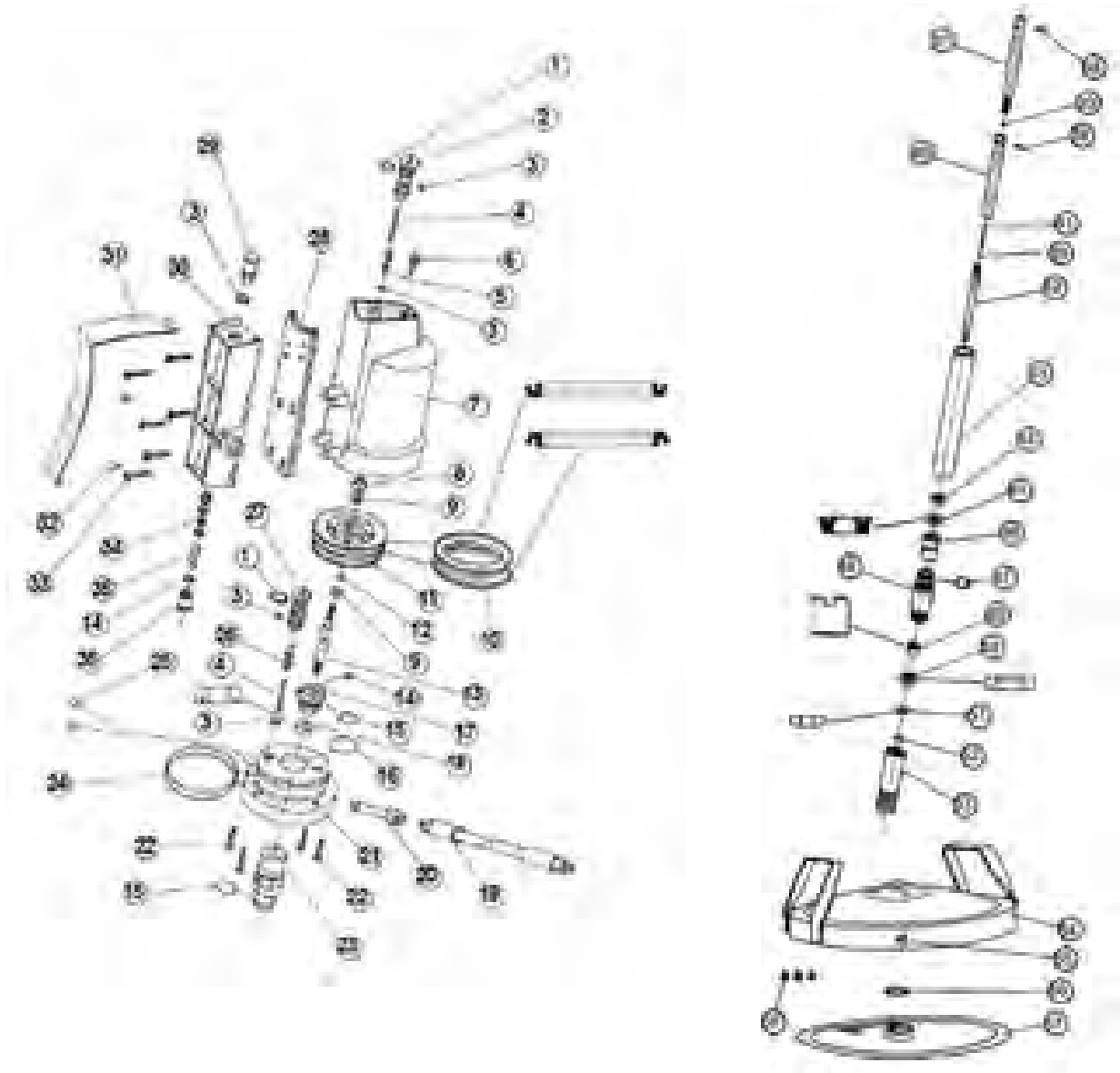

P3-01C, P3001, P6-01, P6001, P8-11, P8001	
Kit Number	Includes Items
P3-1K Air motor kit	1, 2, 3, 4, 5, 8, 9, 10, 11, 12, 14, 15, 16, 17, 18, 24, 25, 26, 27, 28, 32, 34, 35
P3-3K Seal kit	1, 3, 4, 8, 10, 11, 12, 14, 15, 16, 18, 24, 25, 34, 38, 39, 41, 44, 45, 47, 51, 52, 56, 59
P3-5K Lower pump kit	38, 39, 40, 41, 44, 45, 46, 47, 49, 50, 51, 52, 56, 59

For more product information:



SERVICE PARTS

C7-01 / C7N-01 EXPLODED DIAGRAM

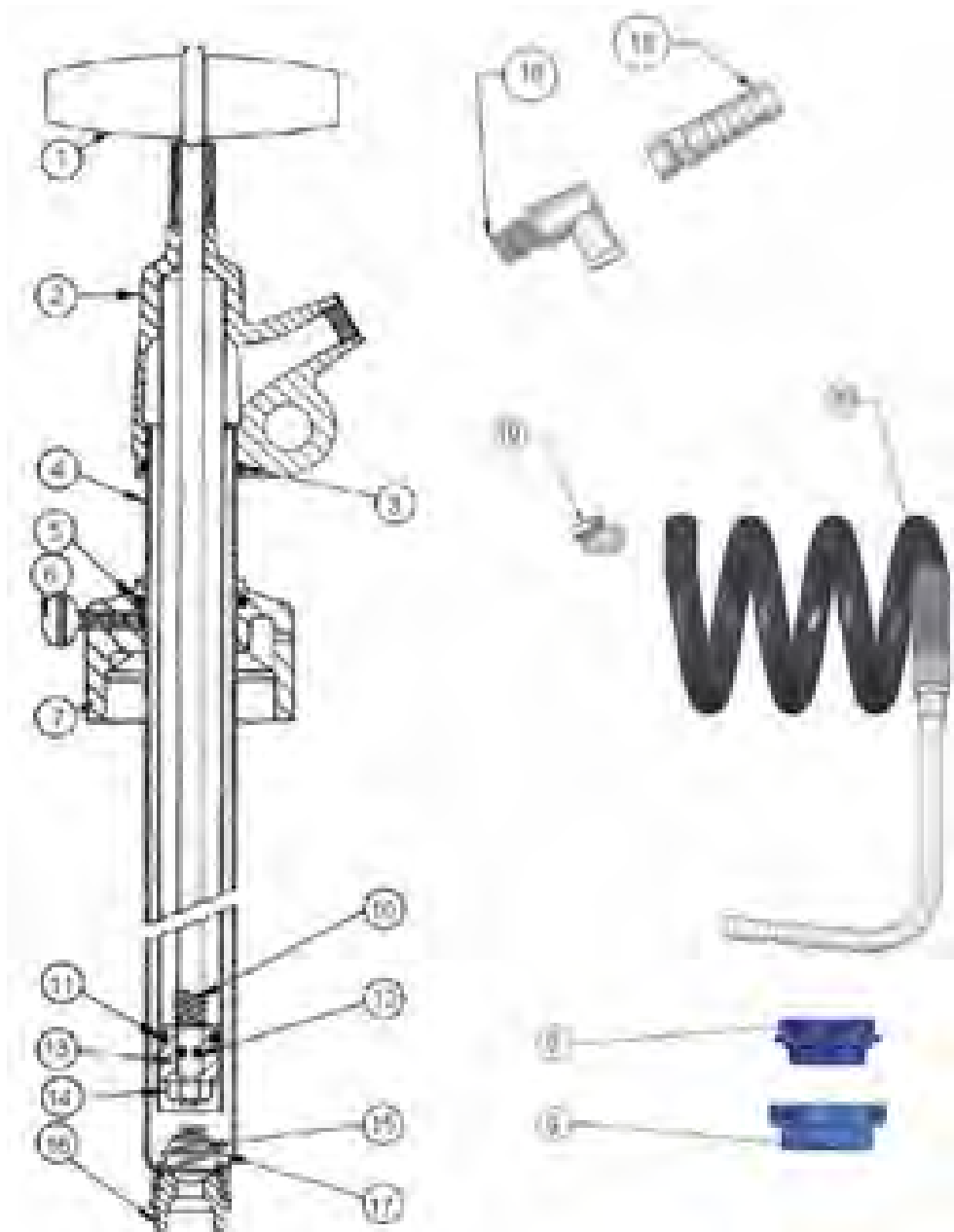

C7-01 / C7N-01 OIL PUMP

Kit Number	Includes Items
C7-1K Seal kit	3, 5, 10, 11, 12, 13, 14
AG88s Hose & nozzle set	19, 20 (Hose and nozzle set)

For more product information:

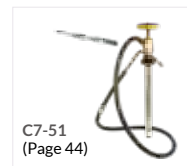
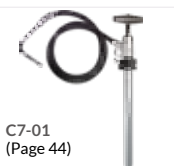

A2H EXPLODED DIAGRAM

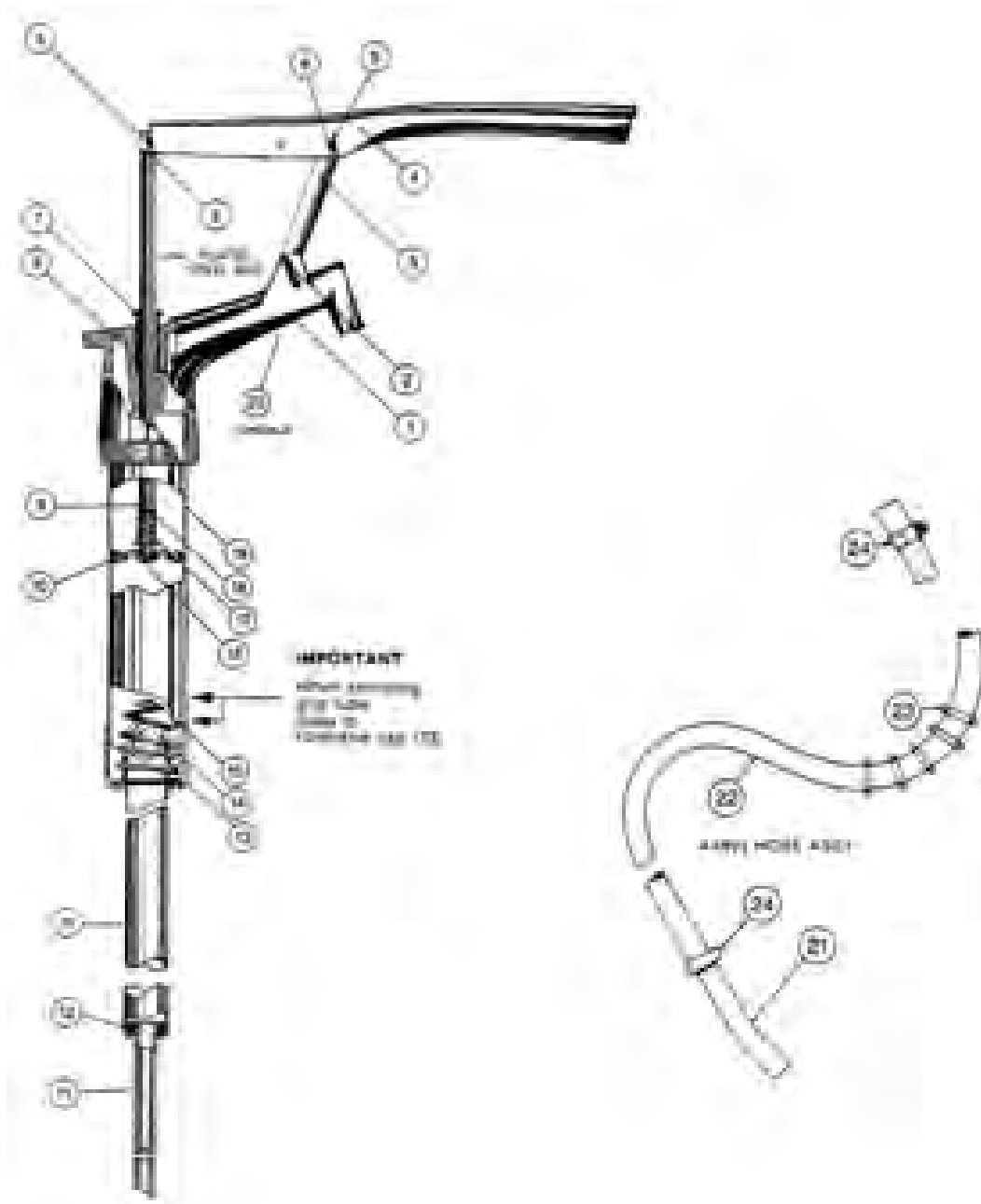

A2H	
Kit Number	Includes Items
A2-1K Seal kit	5, 6, 7, 8, 10, 12, 14, 15, 16, 17, 18, 20
AA92s Hose & nozzle set	21, 22, 23, 24

For more product information:

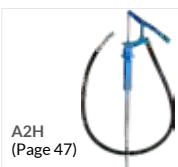

SERVICE PARTS

S20H-01 / S60H-01 EXPLODED DIAGRAM

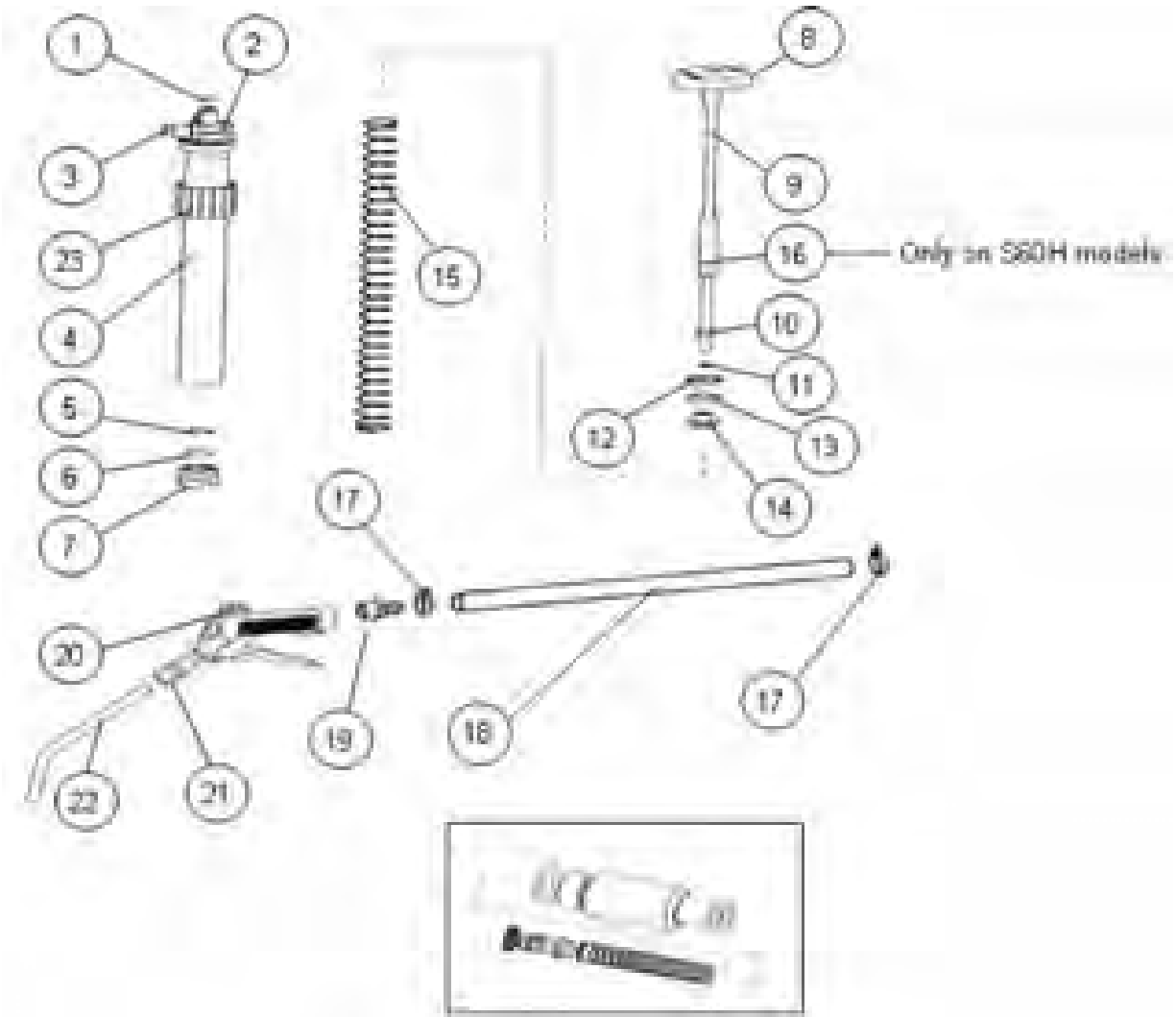

S20H-01	
Kit Number	Includes Items
SA20-1K Seal kit	1, 5, 6, 7, 8, 10, 11, 13
SA026s Hose set	17, 18, 19

S60H-01	
Kit Number	Includes Items
SA60-1K	1, 5, 6, 7, 8, 10, 11, 13
SA026s Hose set	17, 18, 19

For more product information:

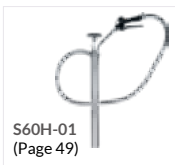
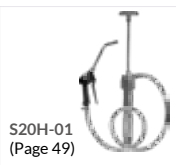

C11-01 EXPLODED DIAGRAM

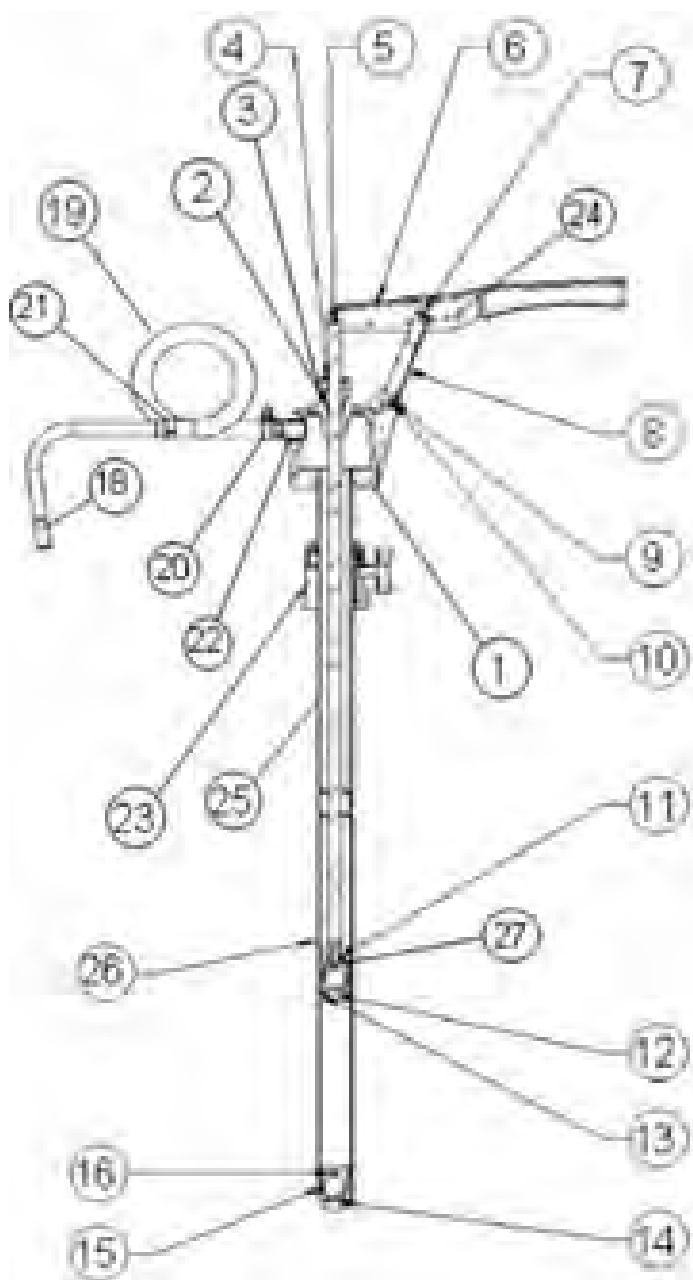

C11-01

Kit Number	Includes Items
C11-1K	2, 3, 4, 7, 8, 9, 11, 13, 14, 15, 16, 17
SA026s Hose & nozzle set	18, 19, 20, 21

For more product information:



C11-01
(Page 48)

SERVICE PARTS

T112T-01 EXPLODED DIAGRAM

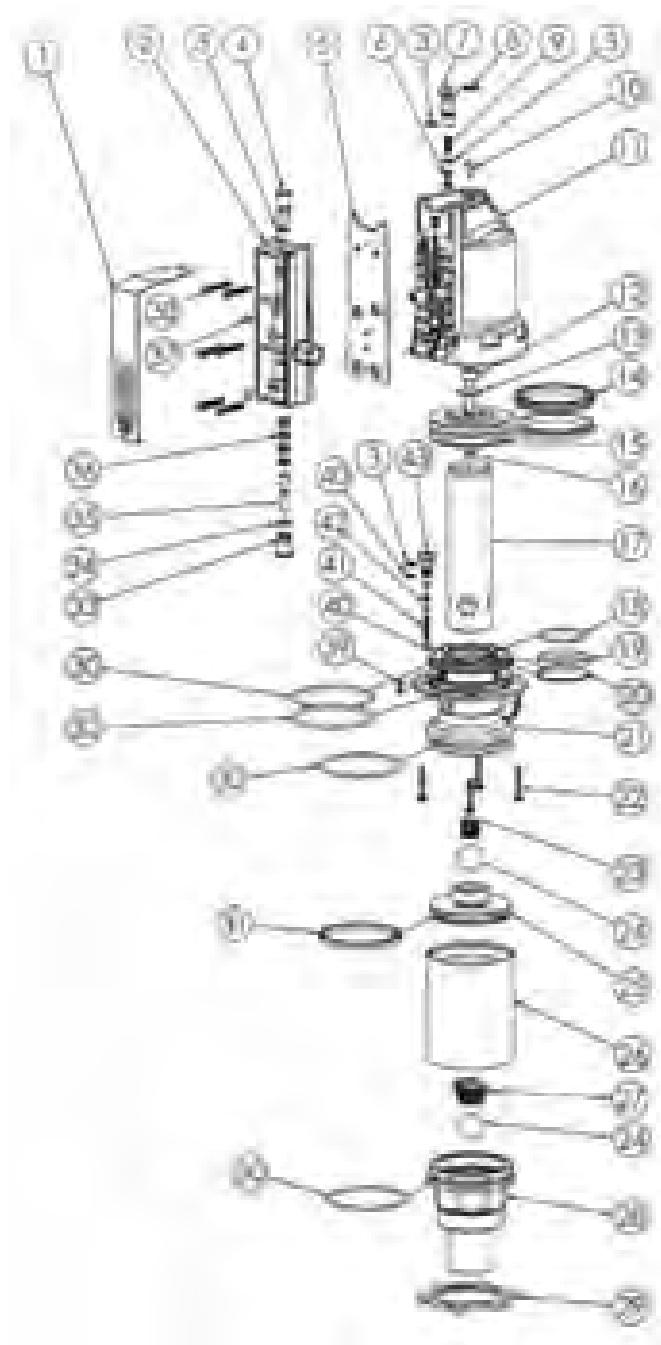

T112T-01	
Kit Number	Includes Items
T112-1K Service kit	3, 4, 5, 6, 7, 8, 9, 12, 13, 14, 15, 16, 18, 19, 20, 30, 31, 32, 34, 35, 36, 37, 39, 40, 41, 42, 43

For more product information:

T112T-01
(Page 51)



T312S-01 / T312T-01 EXPLODED DIAGRAM

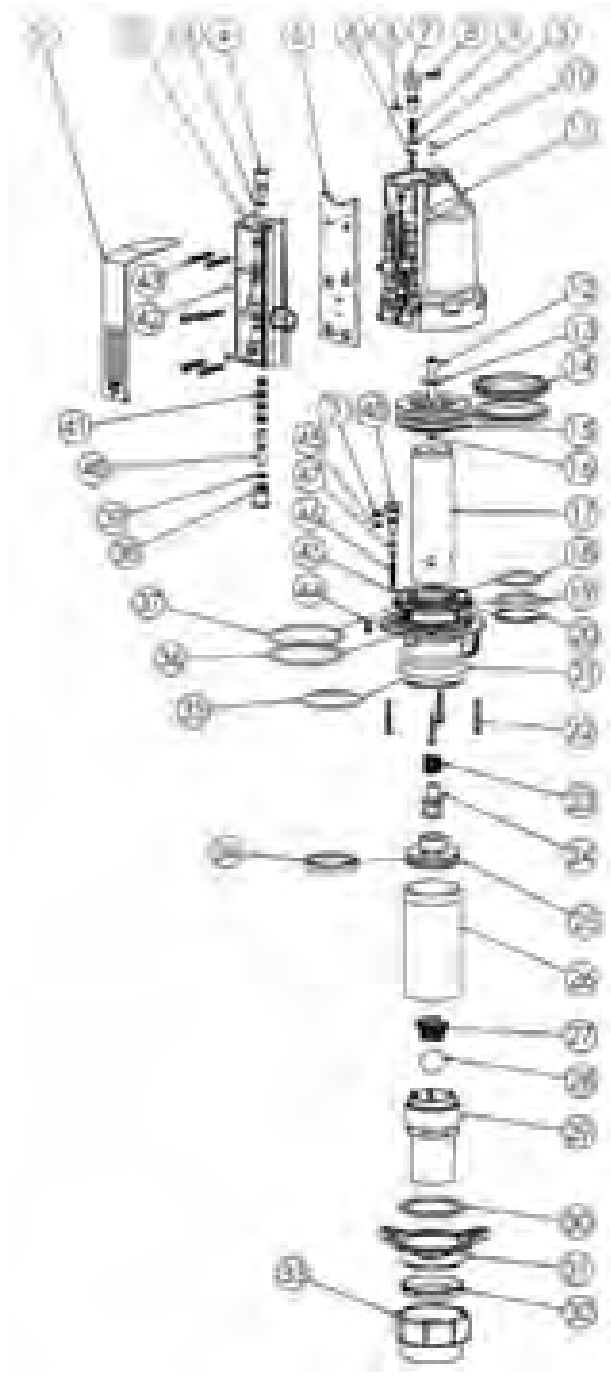

T312S-01, T312T-01

Kit Number	Includes Items
T312-1K Service kit	3, 4, 5, 6, 7, 8, 9, 12, 13, 14, 15, 16, 18, 19, 20, 30, 34, 35, 36, 37, 39, 40, 41, 42, 44, 45, 46, 47, 48

For more product information:

T312S-01
(Page 51)



T312T-01
(Page 51)



SERVICE PARTS

T512S-01/ T512T-01 EXPLODED DIAGRAM

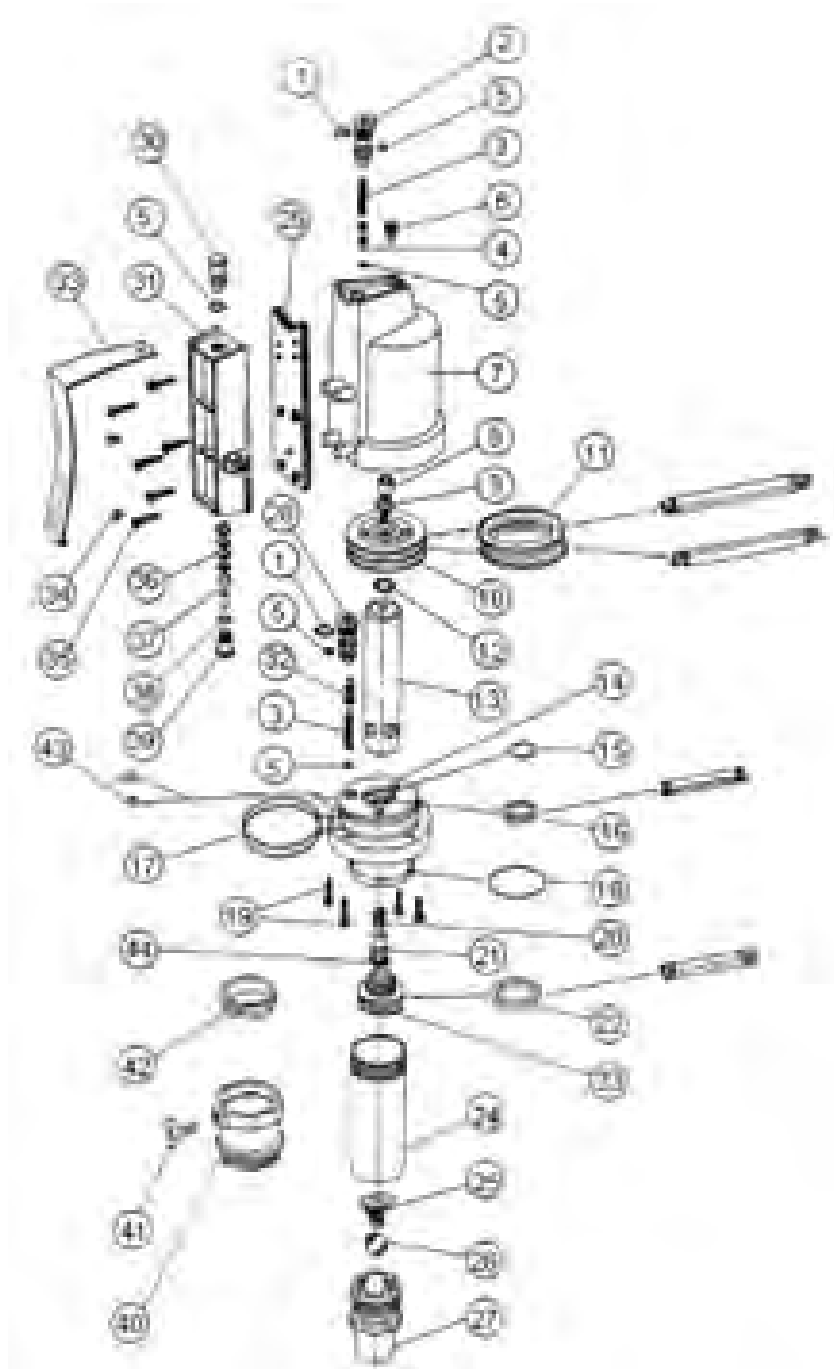

T512S-01/T512T-01	
Kit Number	Includes Items
T512-2K Service kit	1, 2, 3, 4, 5, 8, 9, 12, 15, 16, 18, 20, 22, 25, 28, 29, 32, 34, 36, 37, 38, 43, 44

For more product information:



R100T-01 EXPLODED DIAGRAM



R100T-01

Kit Number	Includes Items
R100-1K Major Overhaul kit	1, 3, 4, 5, 6, 7, 8, 9, 10, 11, 12, 13, 14, 16, 19, 24, 25, 26, 27, 29, 30, 31, 32, 33, 34, 36, 37, 37a, 37b, 37c, 38, 39, 42, 43, 44, 53
R100-2K Seal Kit	1, 3, 4, 5, 6, 9, 10, 13, 14, 16, 19, 24, 25, 26, 29, 30, 32, 34, 36, 37a, 37b, 37c, 38, 39, 42, 53

For more product information:

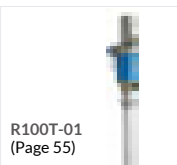

SERVICE PARTS

R300S-01 / R300T-01 EXPLODED DIAGRAM



R300S-01 / R300T-01	
Kit Number	Includes Items
R300-2K Major Overhaul kit	1, 3, 4, 5, 6, 7, 8, 9, 10, 11, 12, 13, 14, 16, 19, 24, 25, 26, 27, 29, 30, 32, 34, 35, 36, 37, 37a, 37b, 38, 39, 42, 43, 44, 45
R300-3K Seal Kit	1, 3, 4, 5, 6, 9, 10, 13, 14, 16, 19, 24, 26, 27, 29, 30, 32, 34, 36, 37a, 37b, 38, 39, 42, 45

For more product information:



R300S-01
(Page 55)

R300T-01
(Page 55)

R500S-01 / R500T-01 EXPLODED DIAGRAM

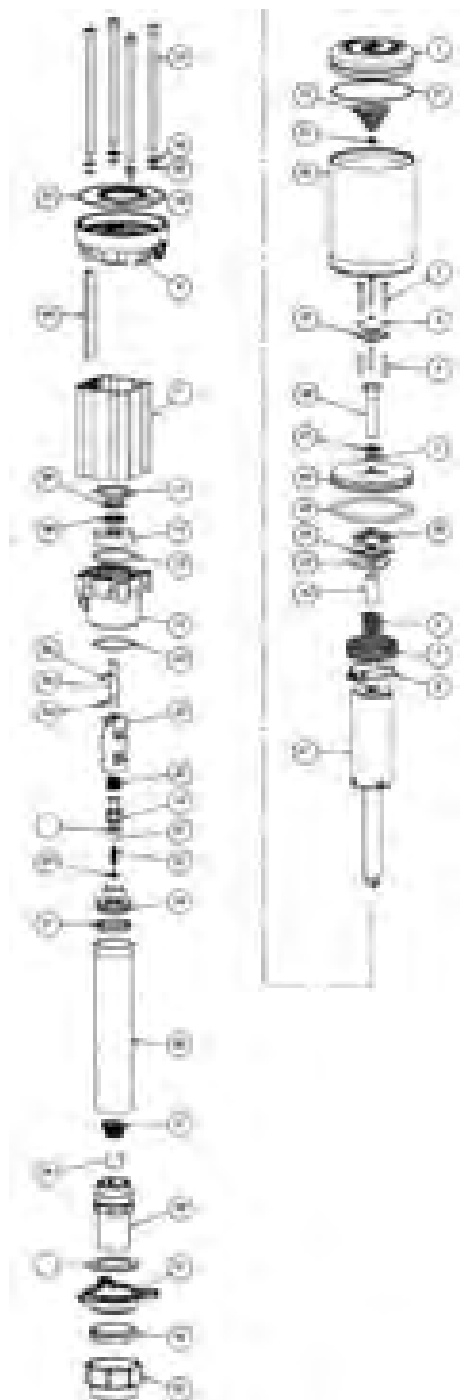

R500S-01 / R500T-01

Kit Number	Includes Items
R500-2K Major Overhaul kit	2, 3, 4, 5, 6, 7, 8, 10, 12, 13, 14, 16, 21, 22, 24, 25, 30, 31, 32, 33, 34, 35, 36, 37, 38, 39, 42, 43, 44, 45, 46, 47, 48, 49, 51, 52, 54, 55, 56, 57
R500-3K Seal Kit	2, 3, 4, 5, 6, 7, 10, 12, 13, 16, 30, 31, 34, 36, 37, 38, 39, 45, 47, 49, 51, 52, 54, 55, 56, 57

For more product information:

R500S-01
(Page 55)



R500T-01
(Page 55)



SERVICE PARTS

R1000S-01 / R1000T-01 EXPLODED DIAGRAM

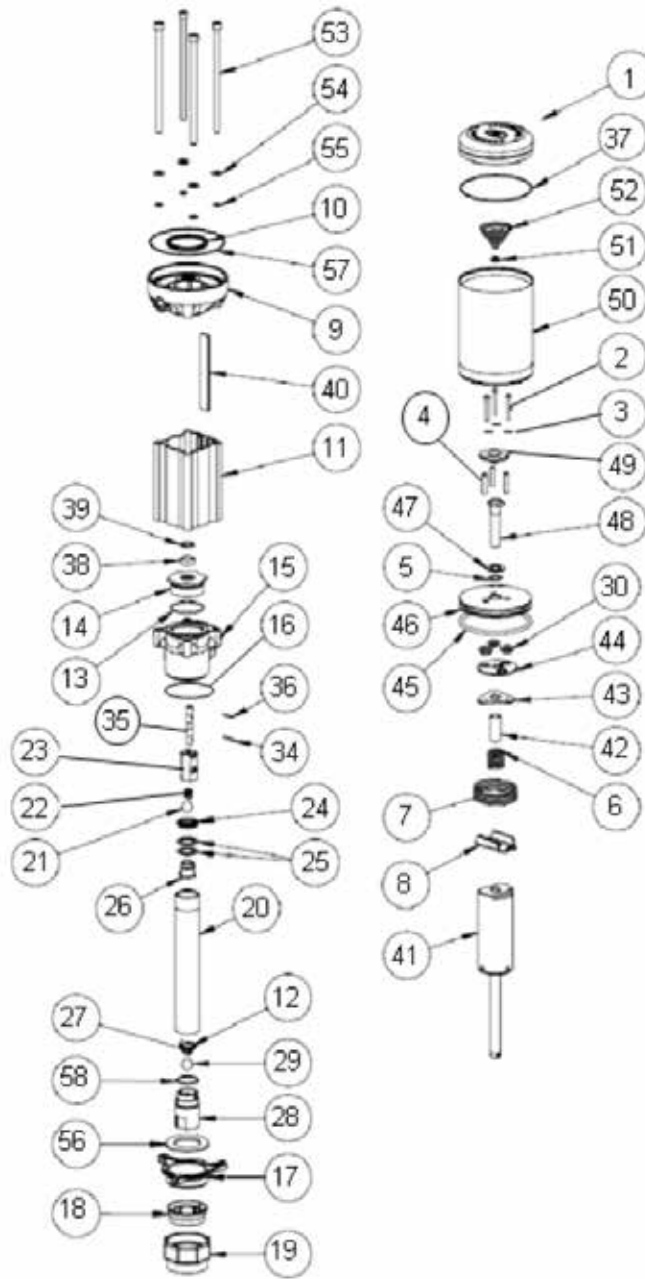

R1000S-01 / R1000T-01	
Kit Number	Includes Items
R1000-2K Major Overhaul kit	2, 3, 4, 5, 6, 7, 8, 10, 11, 13, 14, 16, 21, 22, 24, 25, 29, 30, 31, 32, 33, 34, 35, 36, 37, 38, 39, 42, 43, 44, 45, 46, 47, 48, 49, 51, 52, 54, 55, 56, 57, 58
R1000-3K Seal Kit	2, 3, 4, 5, 6, 7, 10, 13, 16, 30, 34, 36, 37, 38, 39, 45, 47, 49, 51, 52, 54, 55, 56, 57, 58

For more product information:



HG60-01 EXPLODED DIAGRAM

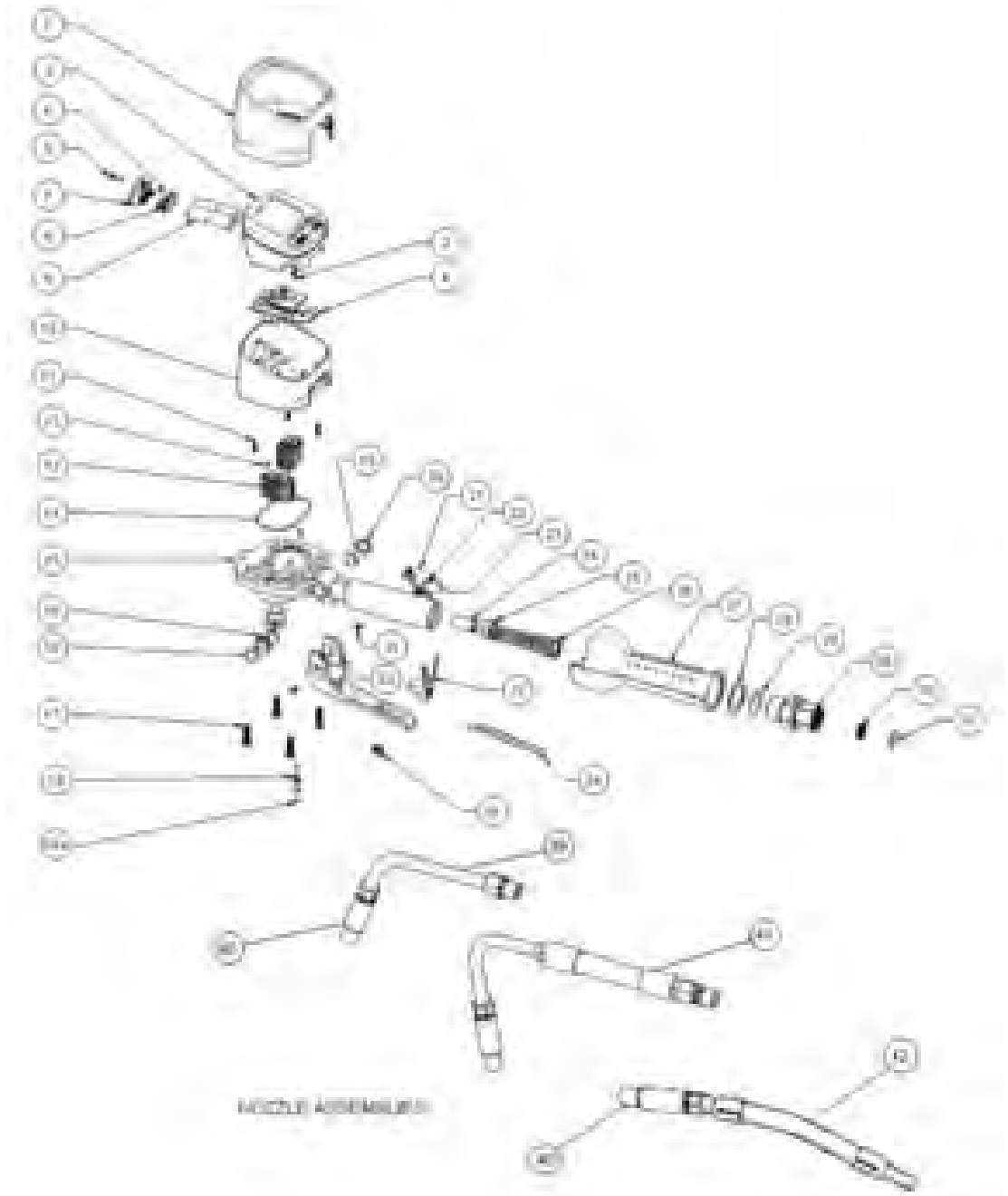

HG60-01	
Kit Number	Includes Items
HG50-1K Major service kit	2, 5, 6, 8, 11, 14, 16, 17, 18, 19, 20, 22, 23, 24, 25, 26, 28, 29, 31, 34, 35, 36, 37
HG50-2K Valve service kit	16, 18, 19, 20, 25, 26, 28, 29, 31, 36, 37
HG370As Electronic module	2 (complete module assembly)

For more product information:



SERVICE PARTS

HG55-01 EXPLODED DIAGRAM

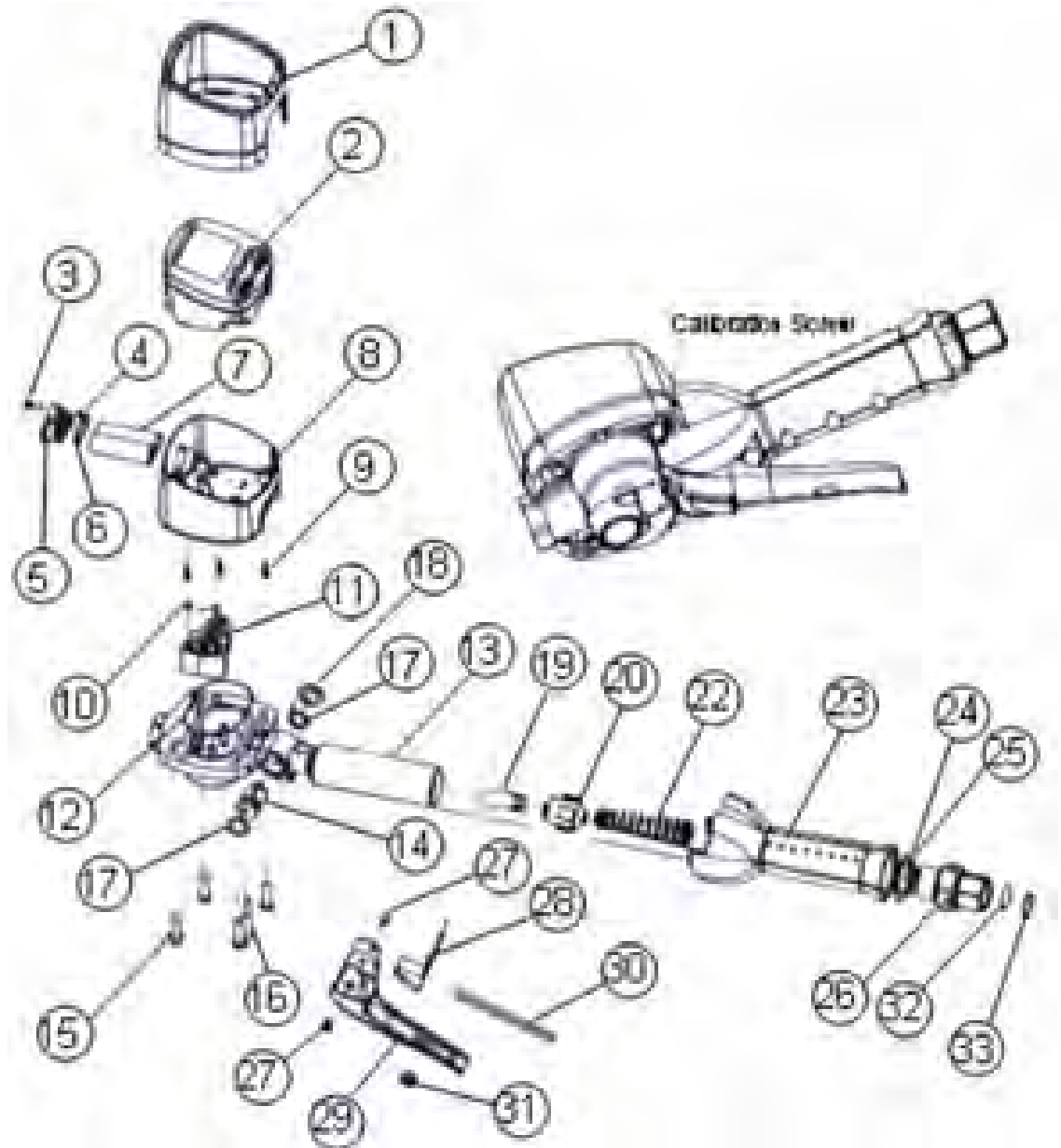

HG55-01	
Kit Number	Includes Items
HG50-1K Major service kit	3, 4, 6, 9, 12, 14, 15, 16, 17, 18, 19, 20, 22, 24, 25, 27, 30, 31, 32, 33
HG50-2K Valve service kit	14, 16, 17, 18, 20, 22, 24, 25, 27, 32, 33
HG369As Electronic module	2 (complete module assembly)

For more product information:



HG55-01
(Page 73)

HG40-01 EXPLODED DIAGRAM

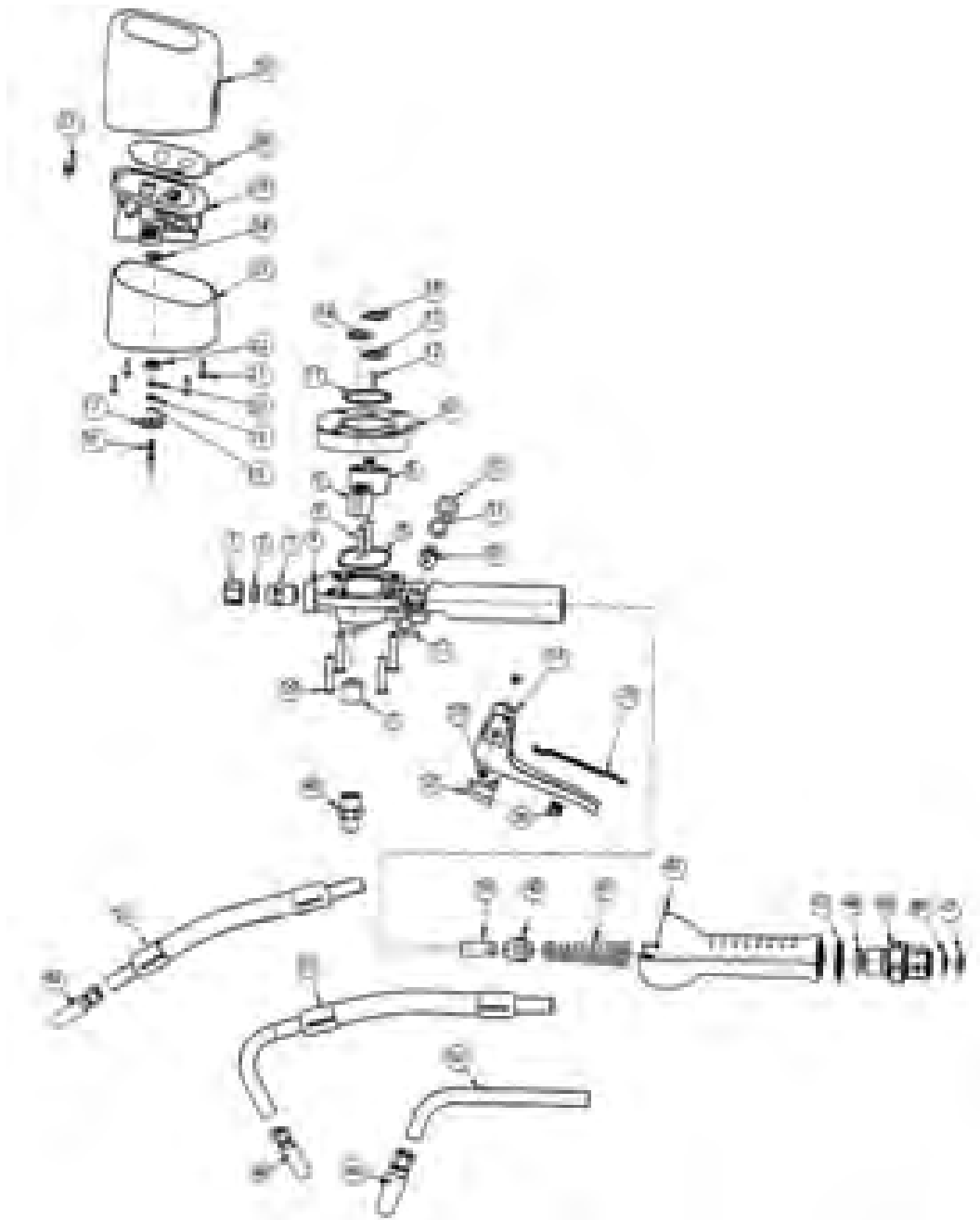

HG40-01	
Kit Number	Includes Items
HG40-1K Major service kit	5, 11, 18, 19, 20, 21, 22, 24, 29, 30, 31, 32, 33, 35, 36, 38, 39, 40, 41, 43, 44, 46, 47
HG50-2K Valve service kit	30, 31, 32, 33, 38, 40, 41, 43, 44, 46, 47
HG200As Electronic module	25 (complete module assembly)

For more product information:



HG40-01
(Page 73)

SERVICE PARTS

HG20F-012E-01 / HG20R-012E-01 EXPLODED DIAGRAM

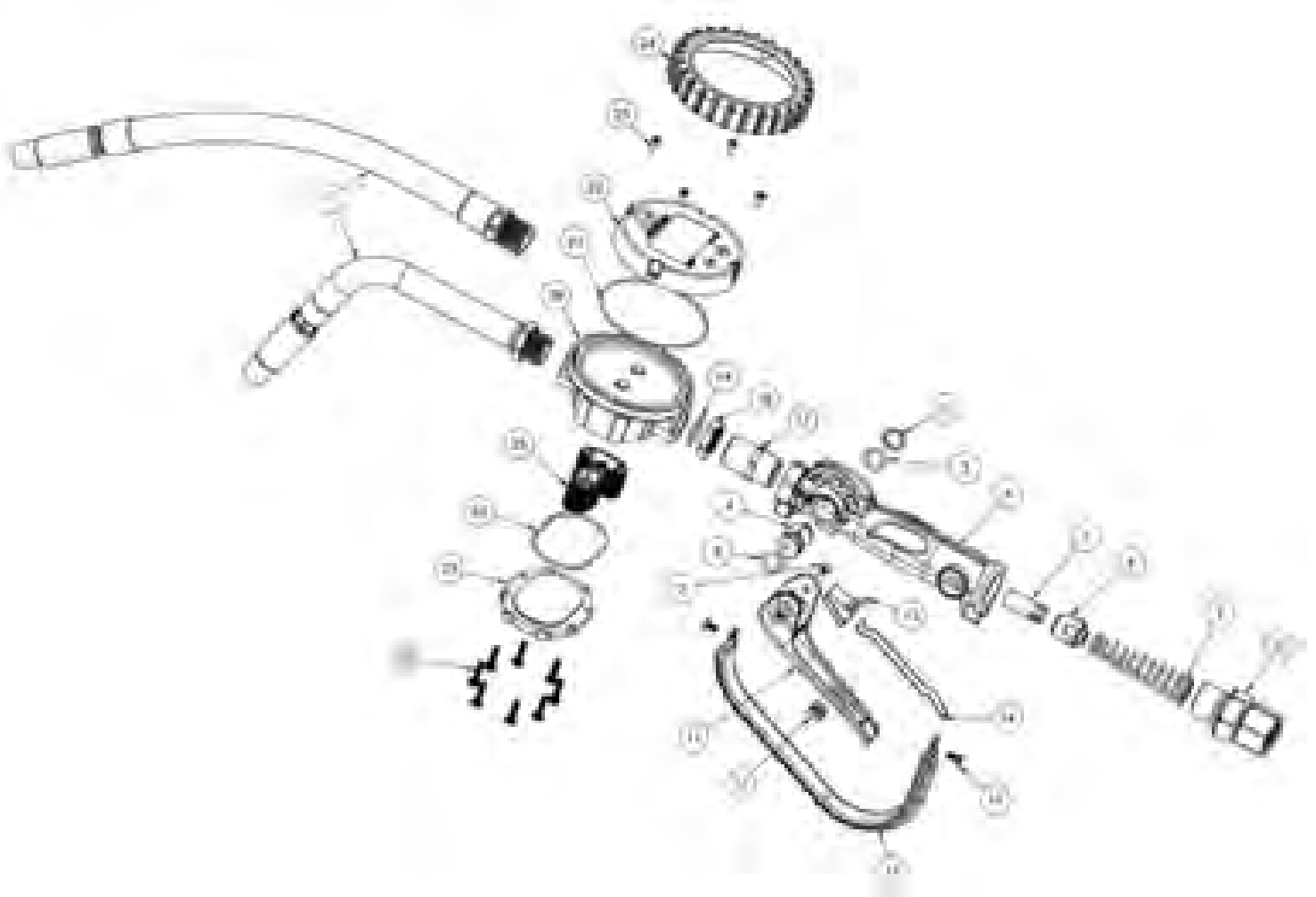

HG20F-012E-01 / HG20R-012E-01	
Kit Number	Includes Items
HG20-1K Seal kit	2, 3, 4, 5, 7, 8, 9, 12, 13, 14, 15
IM078AS Flex extension	1 (Flexible extension with auto nozzle)
HG200As Rigid extension	1 (Rigid extension with auto nozzle)

For more product information:



HG20F-012E-01
(Page 69)



HG20R-012E-01
(Page 69)

HG20F-012M-01 / HG20R-012M-01 EXPLODED DIAGRAM

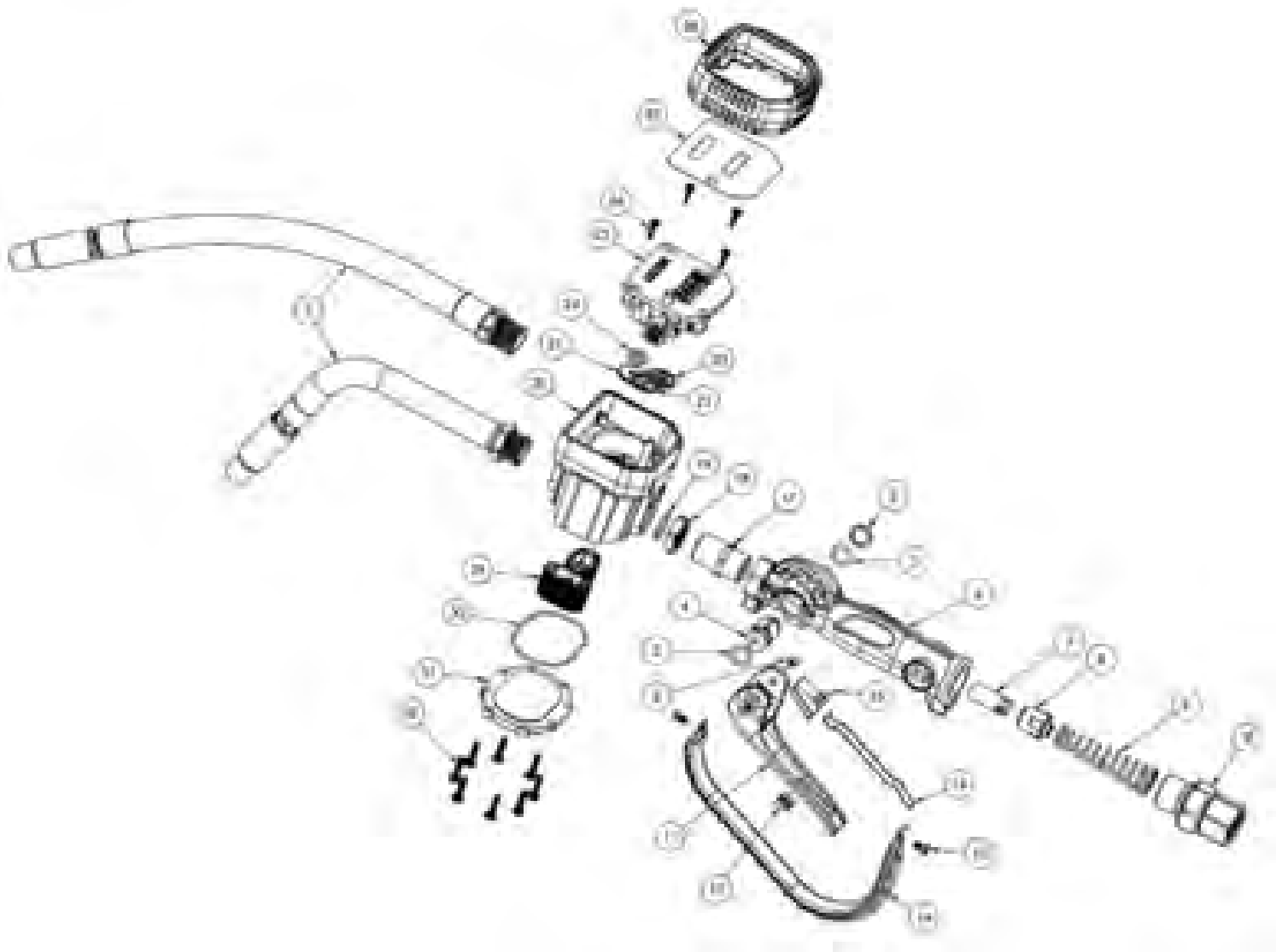

HG20F-012M-01 / HG20R-012M-01	
Kit Number	Includes Items
HG20-1K Seal kit	2, 3, 4, 5, 7, 8, 9, 12, 13, 14, 15
IM078AS Flex Extension	1 (Flexible extension with auto nozzle)
IM106AS Rigid extension	1 (Rigid extension with auto nozzle)

For more product information:



HG20F-012M-01
(Page 69)



HG20R-012M-01
(Page 69)

SERVICE PARTS

HG20F-01 / HG20R-01 EXPLODED DIAGRAM

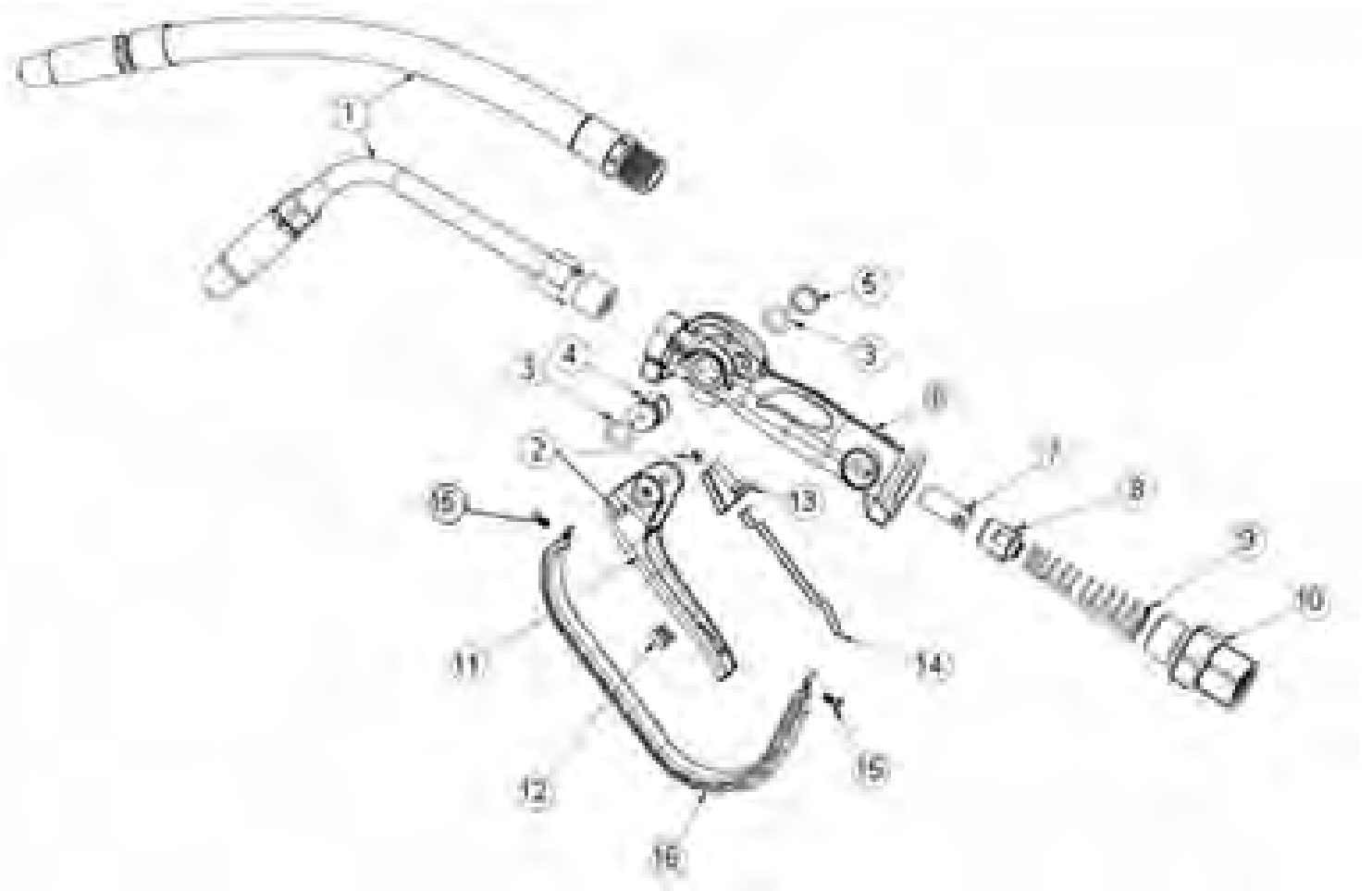

HG20F-01 / HG20R-01	
Kit Number	Includes Items
HG20-1K Seal kit	2, 3, 4, 5, 7, 8, 9, 12, 13, 14, 15
IM078AS Flex Extension	1 (Flexible extension with auto nozzle)
HG510AS Rigid extension	1 (Rigid extension with auto nozzle)

Note: For parts not listed above please refer to instruction manual listed on the Macnaught website www.macnaught.com.au

For more product information:

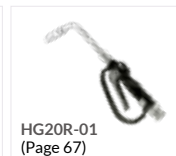

HG100-019E-01 EXPLODED DIAGRAM

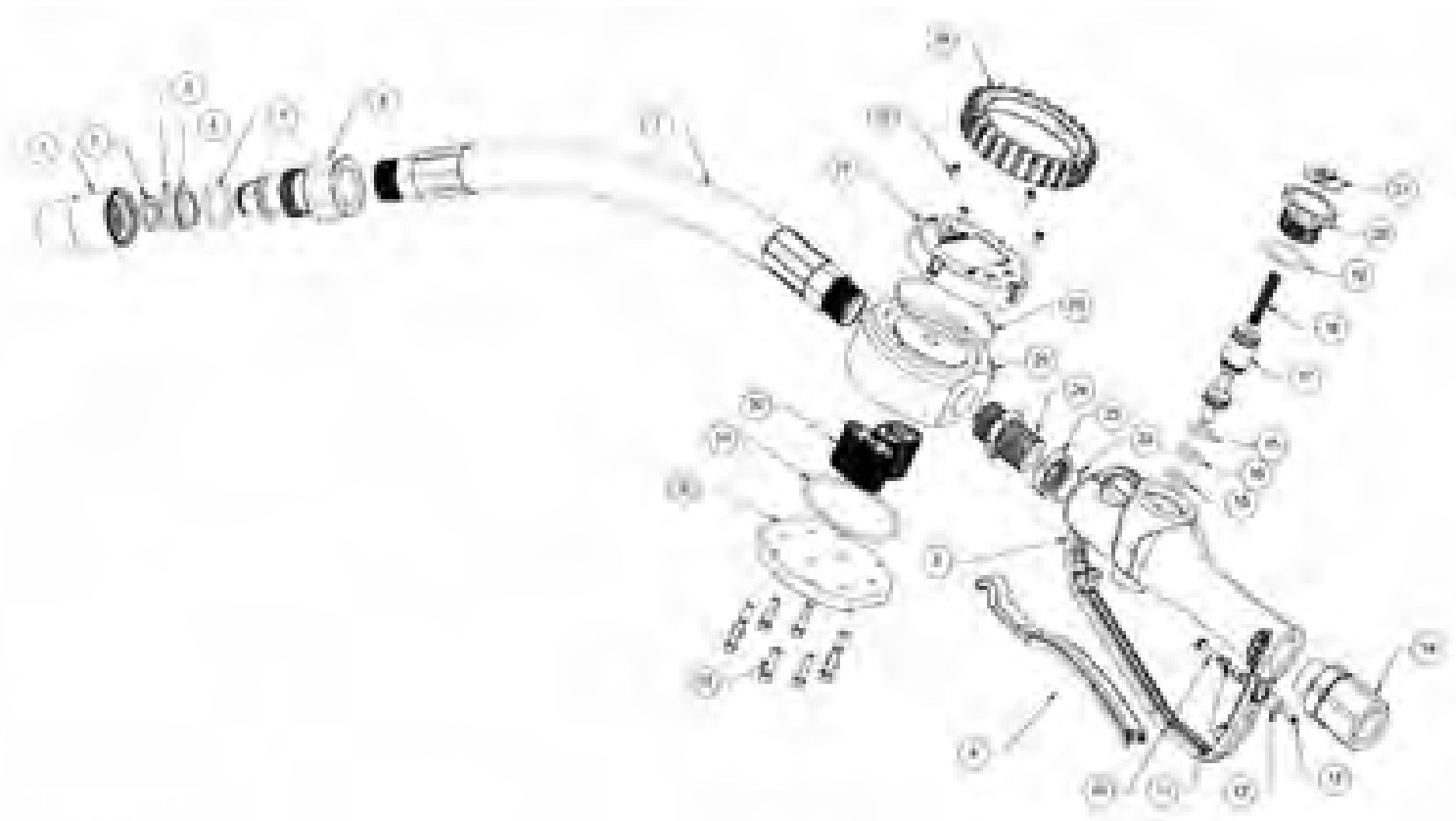

HG100-019E-01

Kit Number	Includes Items
HG100-1K Seal kit	2, 3, 4, 5, 10, 11, 12, 13, 15, 16, 18.19
HG424s Flex Extension	1 (Flexible extension with manual nozzle)

Note: For parts not listed above please refer to instruction manual listed on the Macnaught website www.macnaught.com.au

For more product information:



HG100-019E-01
(Page 71)

SERVICE PARTS

HG100-01 EXPLODED DIAGRAM

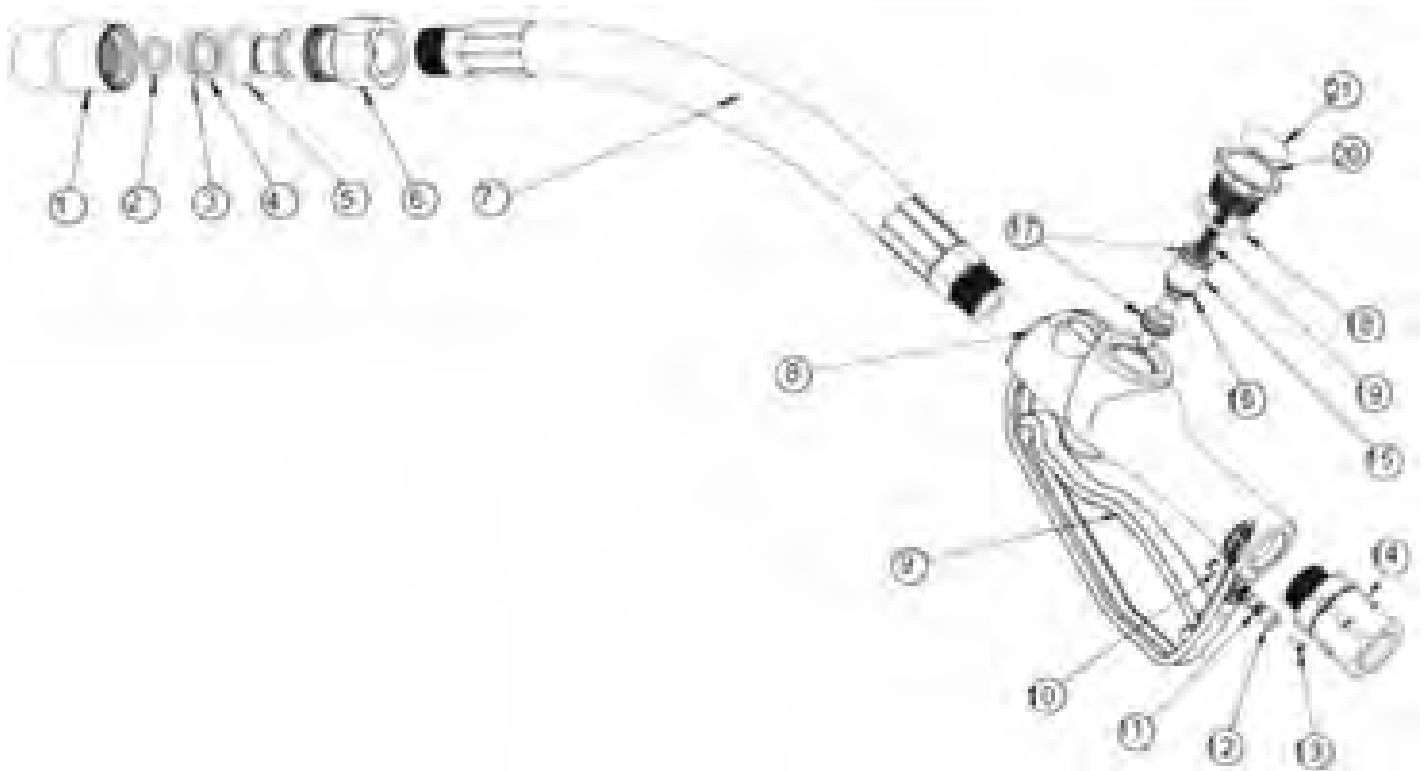

HG100-01	
Kit Number	Includes Items
HG100-1K Seal kit	2, 3, 4, 5, 10, 11, 12, 13, 15, 16, 18, 19
HG424s Flex Ext with nozzle	1 (Flexible extension with manual nozzle)

Note: For parts not listed above please refer to instruction manual listed on the Macnaught website www.macnaught.com.au

For more product information:

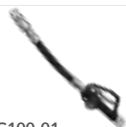

HG100-01
(Page 71)

SERVICE PARTS

IM012M-01 EXPLODED DIAGRAM

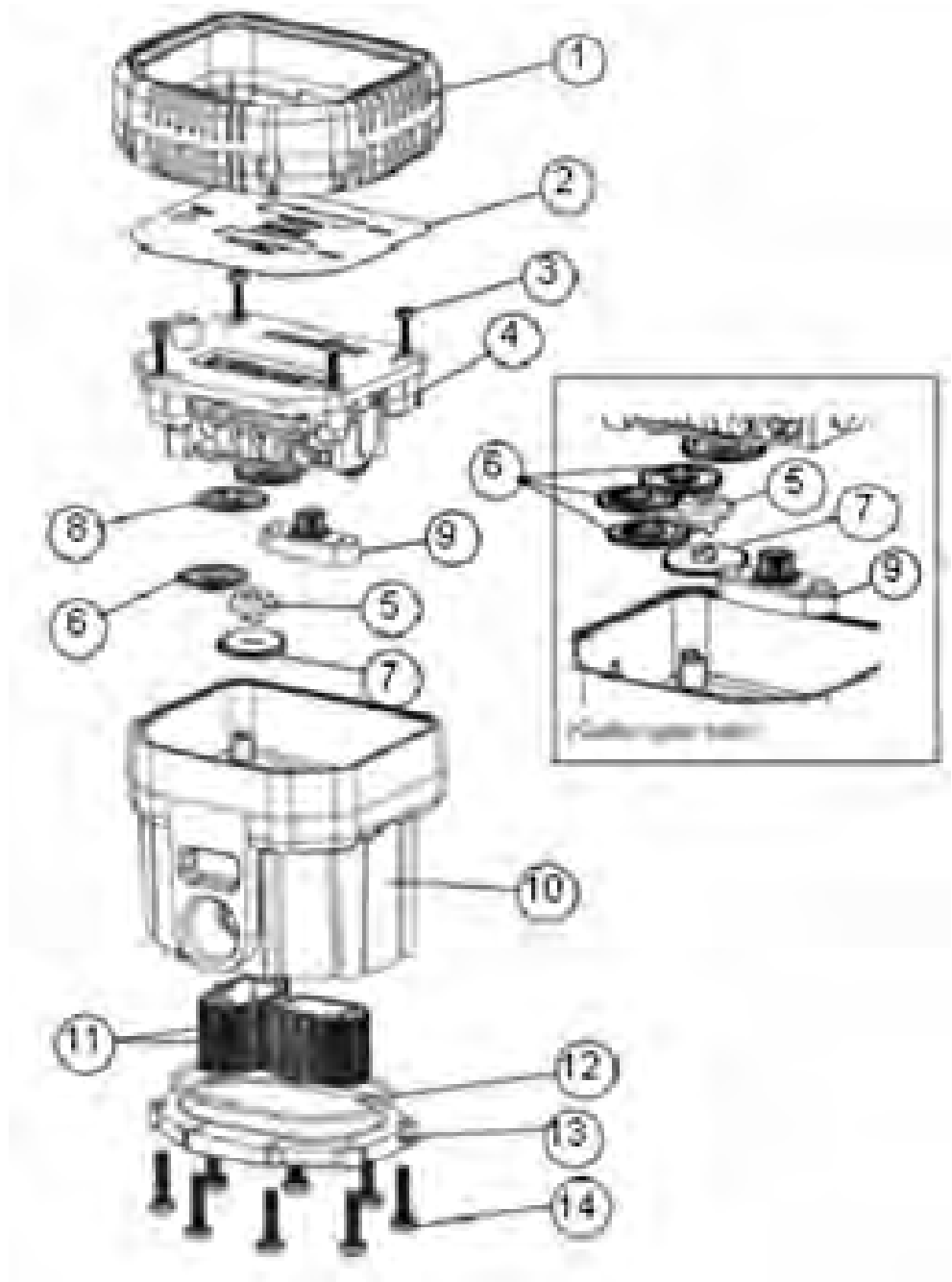

IM012M-01	
Kit Number	Includes Items
IM168As Register Assembly	4 (Register assembly)
IM176s Gear set (litre)	5, 6, 7, 8, 9
IM181s Rotor set	11, 12

Note: For parts not listed above please refer to instruction manual listed on the Macnaught website www.macnaught.com.au

For more product information:



IM012M-01
(Page 75)

IM019E-01 EXPLODED DIAGRAM

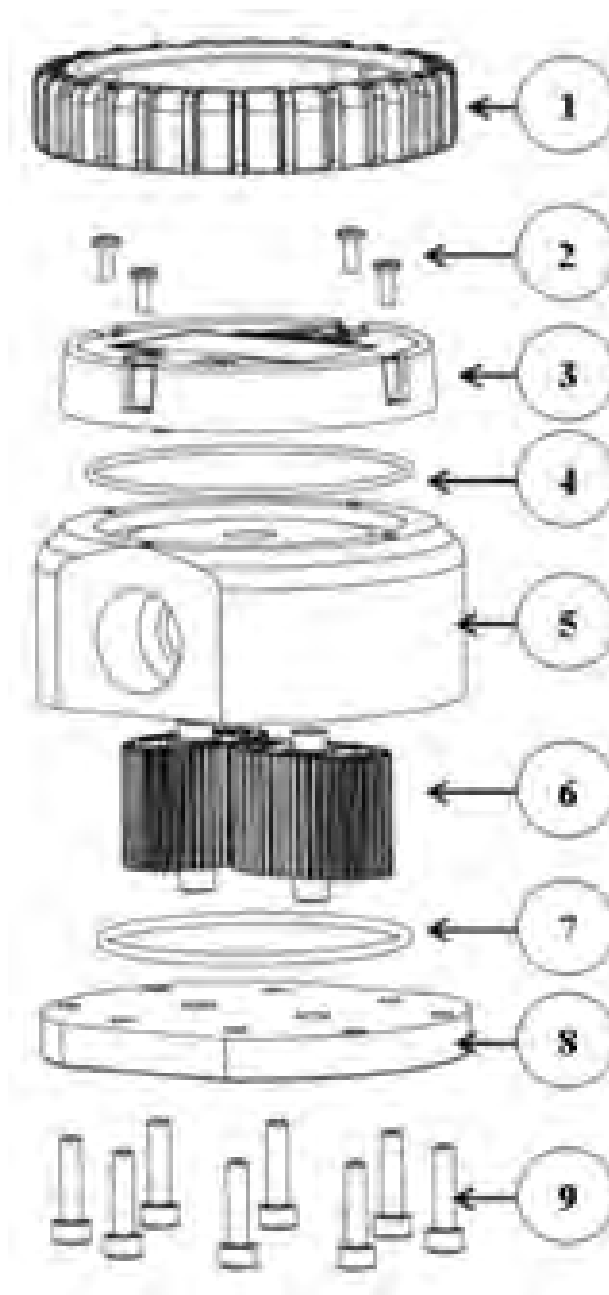

IM019E-01

Kit Number	Includes Items
DKIT-IM019-MC Module	2, 3, 4 (Electronic module)
MKIT-IM019-01 Rotor set	6, 7 (Rotor set)

Note: For parts not listed above please refer to instruction manual listed on the Macnaught website www.macnaught.com.au

For more product information:



IM019E-01
(Page 75)

SERVICE PARTS

GT-01 EXPLODED DIAGRAM

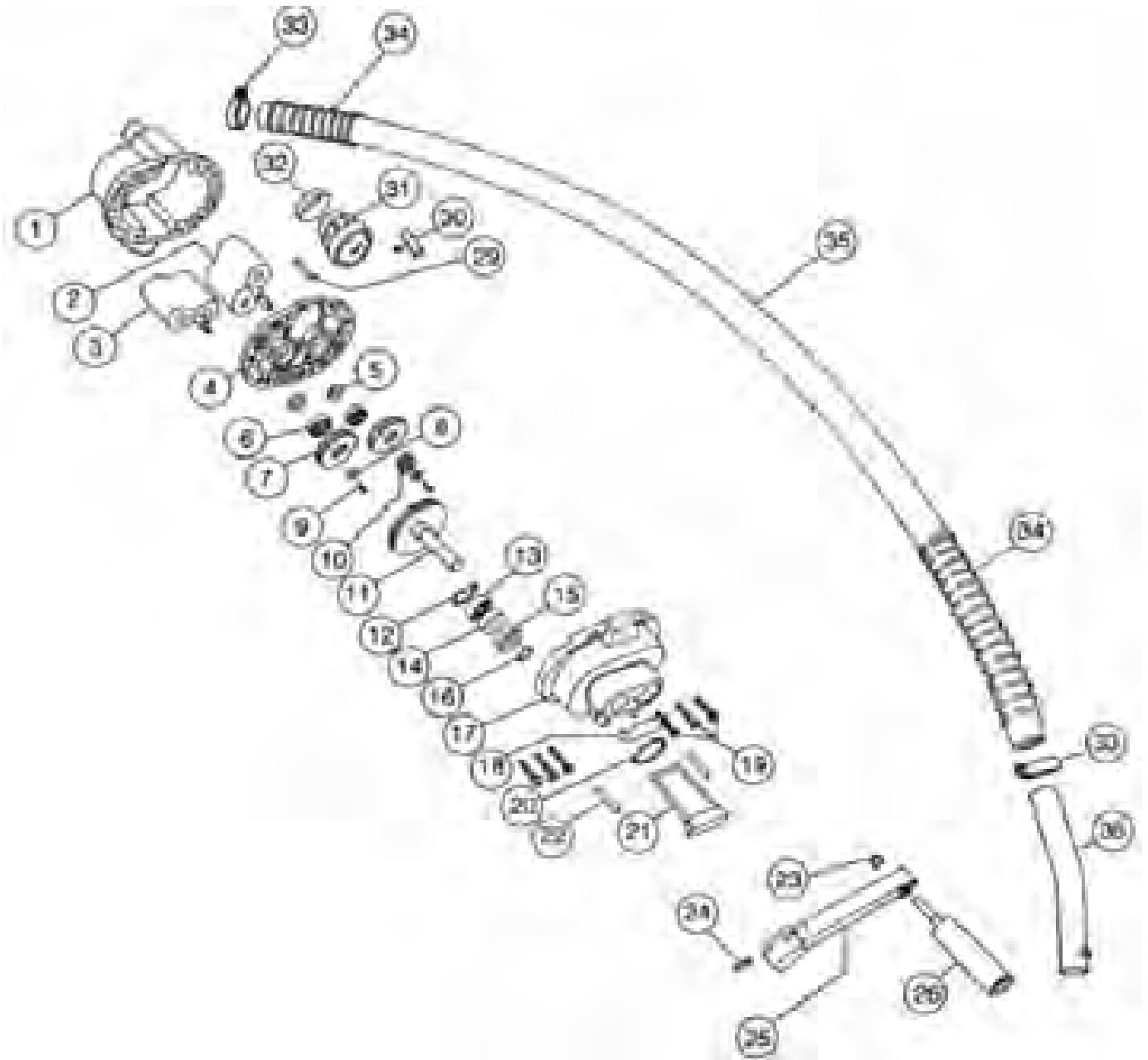

GT-01	
Kit Number	Includes Items
GM-1K Seal and bearing kit	5, 6, 9, 12, 13, 14, 15, 16, 18, 20, 21, 22, 32,
ST005As Suction tube set	27, 27a, 28

Note: For parts not listed above please refer to instruction manual listed on the Macnaught website www.macnaught.com.au

For more product information:

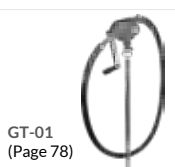

GT-01
(Page 78)

AFP12A / AFP12M / AFP24A / AFP24M EXPLODED DIAGRAM

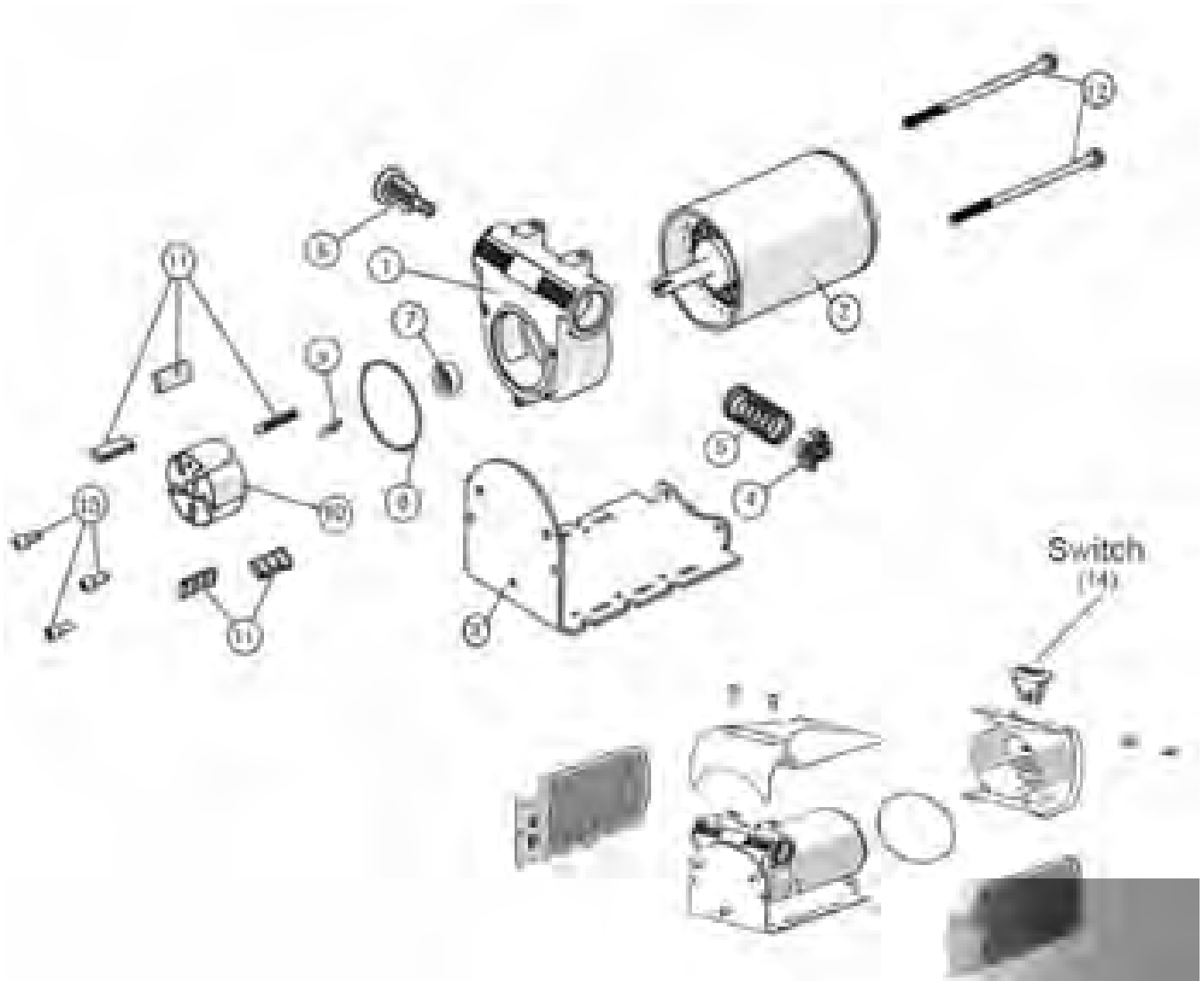

AFP12A / AFP12M / AFP24A / AFP24M

Kit Number	Includes Items
AFP12-1K Wet kit	7, 8, 9, 11
AFP12-2K Poppet valve kit	4, 5, 6
A40LPM-SWITCH	14

Note: For parts not listed above please refer to instruction manual listed on the Macnaught website www.macnaught.com.au

For more product information:



AFP12A
(Page 83)



AFP12M
(Page 83)



AFP24A
(Page 83)



AFP24M
(Page 83)

SERVICE PARTS

AHFP12A EXPLODED DIAGRAM

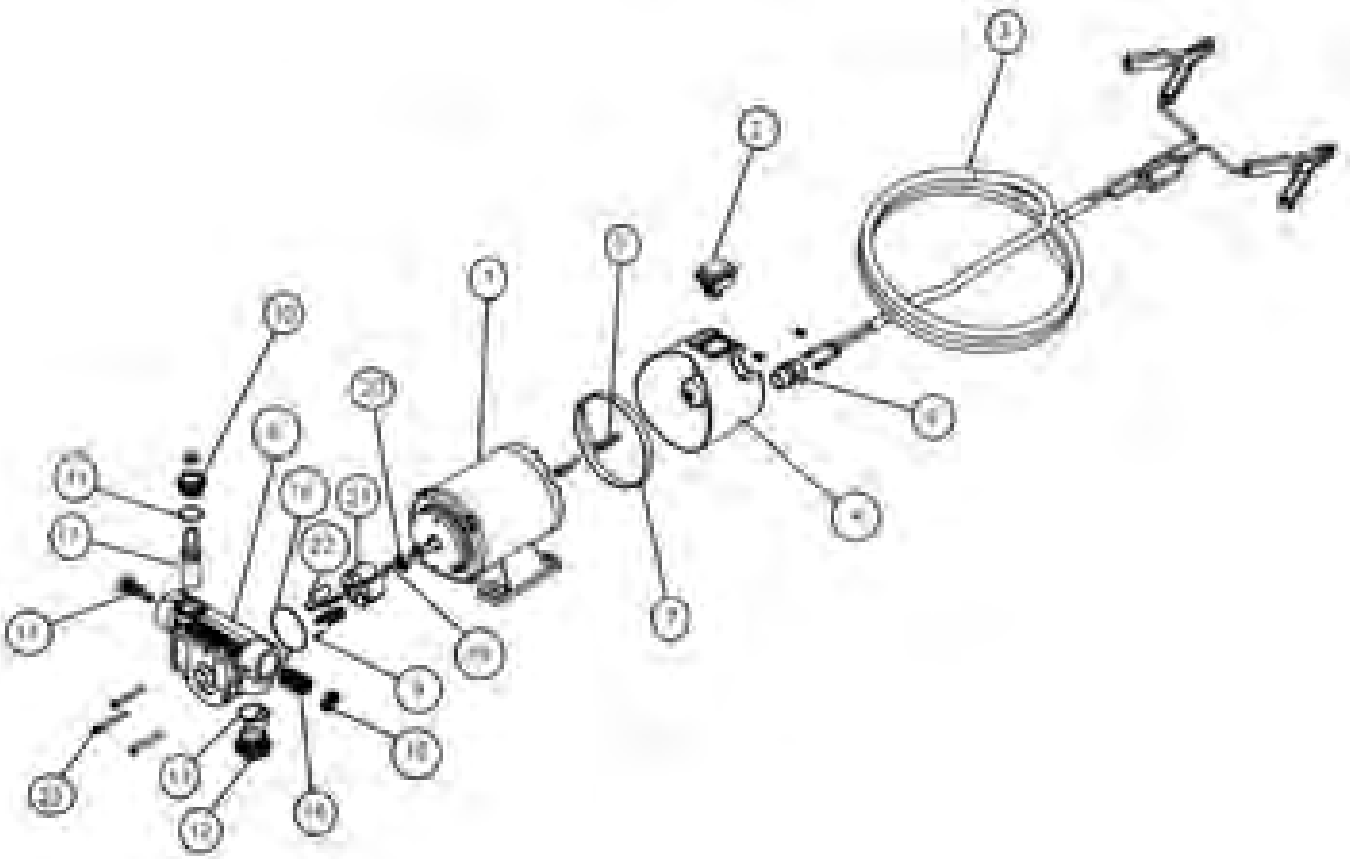

AHFP12A	
Kit Number	Includes Items
AFP12-1K Wet kit	11, 13, 18, 19, 20, 22
AHFP12-2K Poppet valve kit	14, 15, 16
AHFP-SWITCH	2

Note: For parts not listed above please refer to instruction manual listed on the Macnaught website www.macnaught.com.au

For more product information:



AHFP85L-12A EXPLODED DIAGRAM

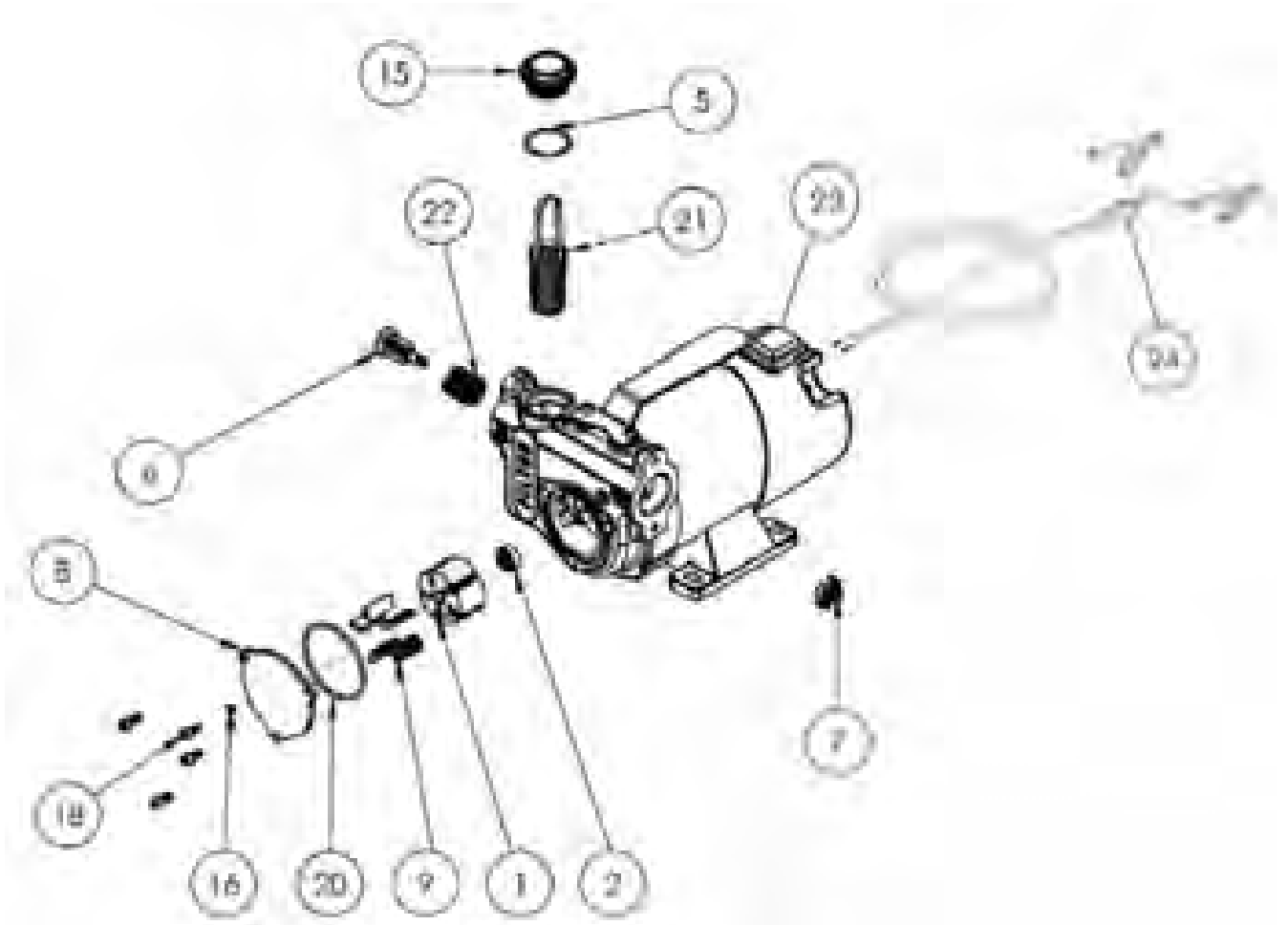

AHFP85L-12A

Kit Number	Includes Items
AHFP85L-1K Wet Kit	2, 5, 6, 7, 9, 16, 18, 20, 21, 22
AHFP12-2K Poppet valve kit	6, 7, 22
AHFP-SWITCH	23

Note: For parts not listed above please refer to instruction manual listed on the Macnaught website www.macnaught.com.au

For more product information:



AHFP85L-12A
(Page 84)

SERVICE PARTS

AHFP70LPM EXPLODED DIAGRAM

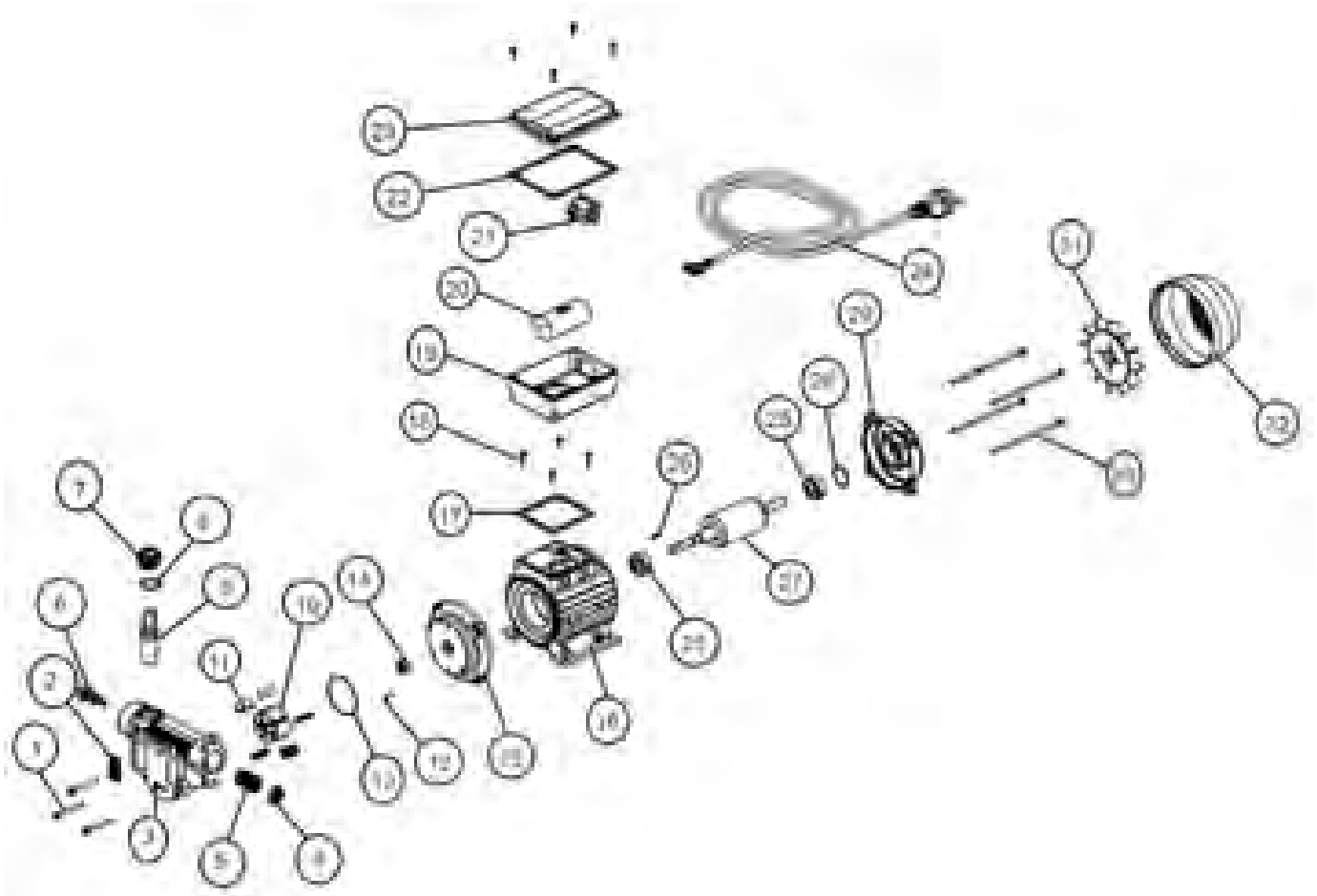

AHFP70LPM	
Kit Number	Includes Items
AHFP70LPM-1K Wet Kit	8, 11, 12, 13, 14
AHFP70LPM-2K Poppet valve kit	4, 5, 6
AHFP-SWITCH	21

Note: For parts not listed above please refer to instruction manual listed on the Macnaught website www.macnaught.com.au

For more product information:



AHFP100LPM EXPLODED DIAGRAM

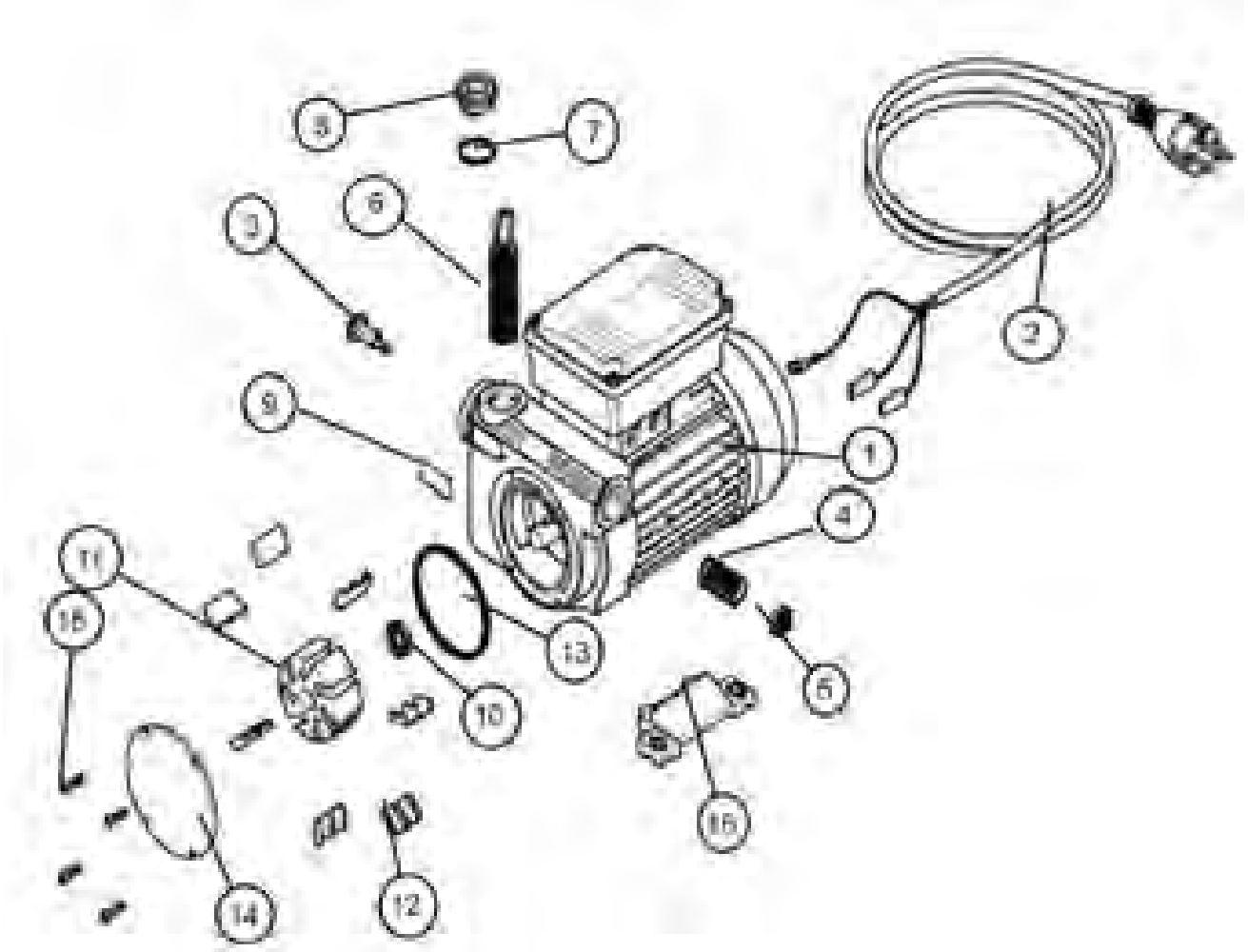

AHFP100LPM

Kit Number	Includes Items
AHFP100LPM-1K Wet Kit	7, 10, 12, 13
AHFP100LPM-2K Poppet valve kit	3, 4, 5

Note: For parts not listed above please refer to instruction manual listed on the Macnaught website www.macnaught.com.au

For more product information:



AHFP100LPM
(Page 85)

SERVICE PARTS

AHFP150LPM EXPLODED DIAGRAM

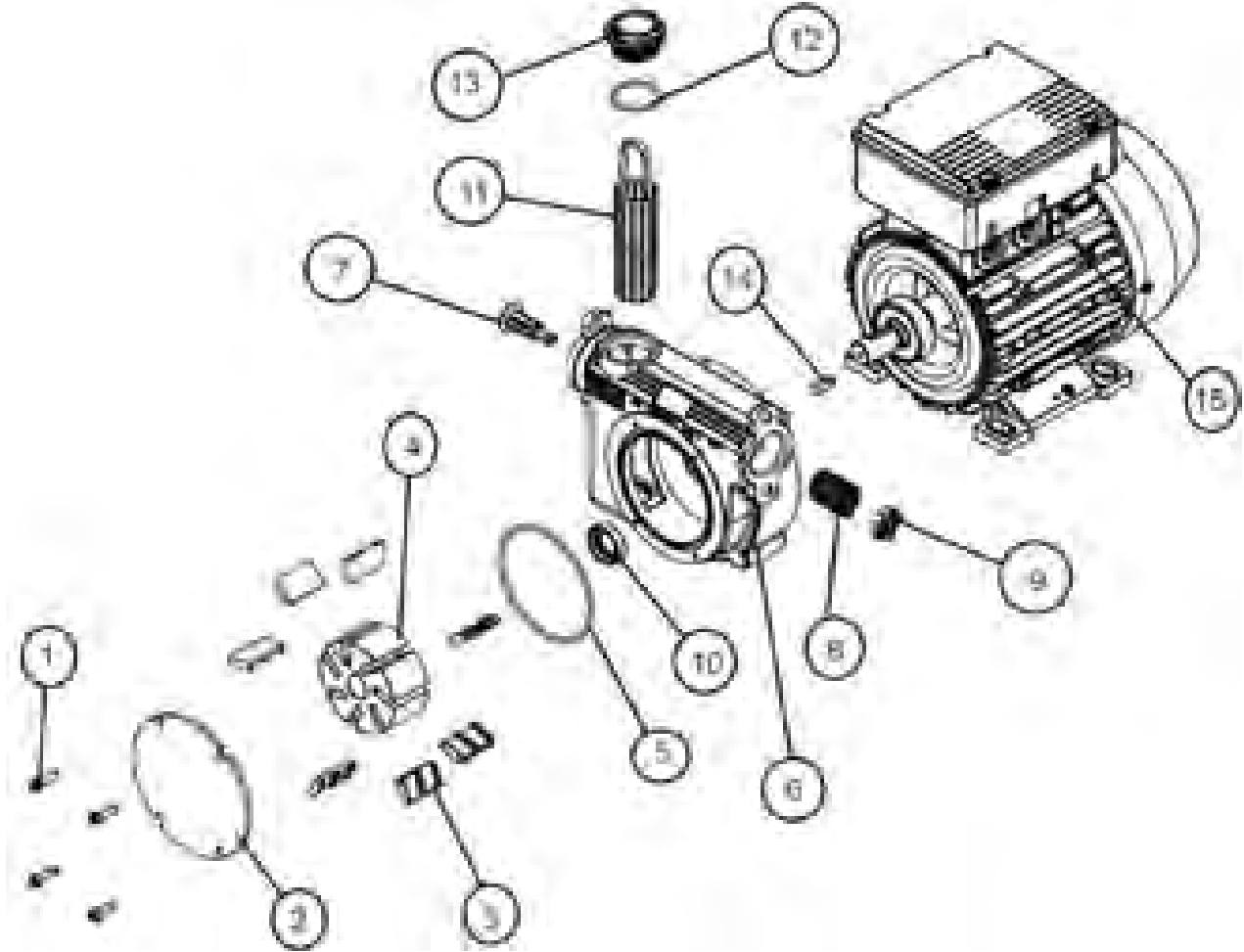

AHFP150LPM	
Kit Number	Includes Items
AHFP150LPM-1K Wet Kit	3, 5, 10, 12, 14
AHFP150LPM-2K Poppet valve kit	7, 8, 9

Note: For parts not listed above please refer to instruction manual listed on the Macnaught website www.macnaught.com.au

For more product information:



AHFP150LPM
(Page 85)

AMB60L EXPLODED DIAGRAM

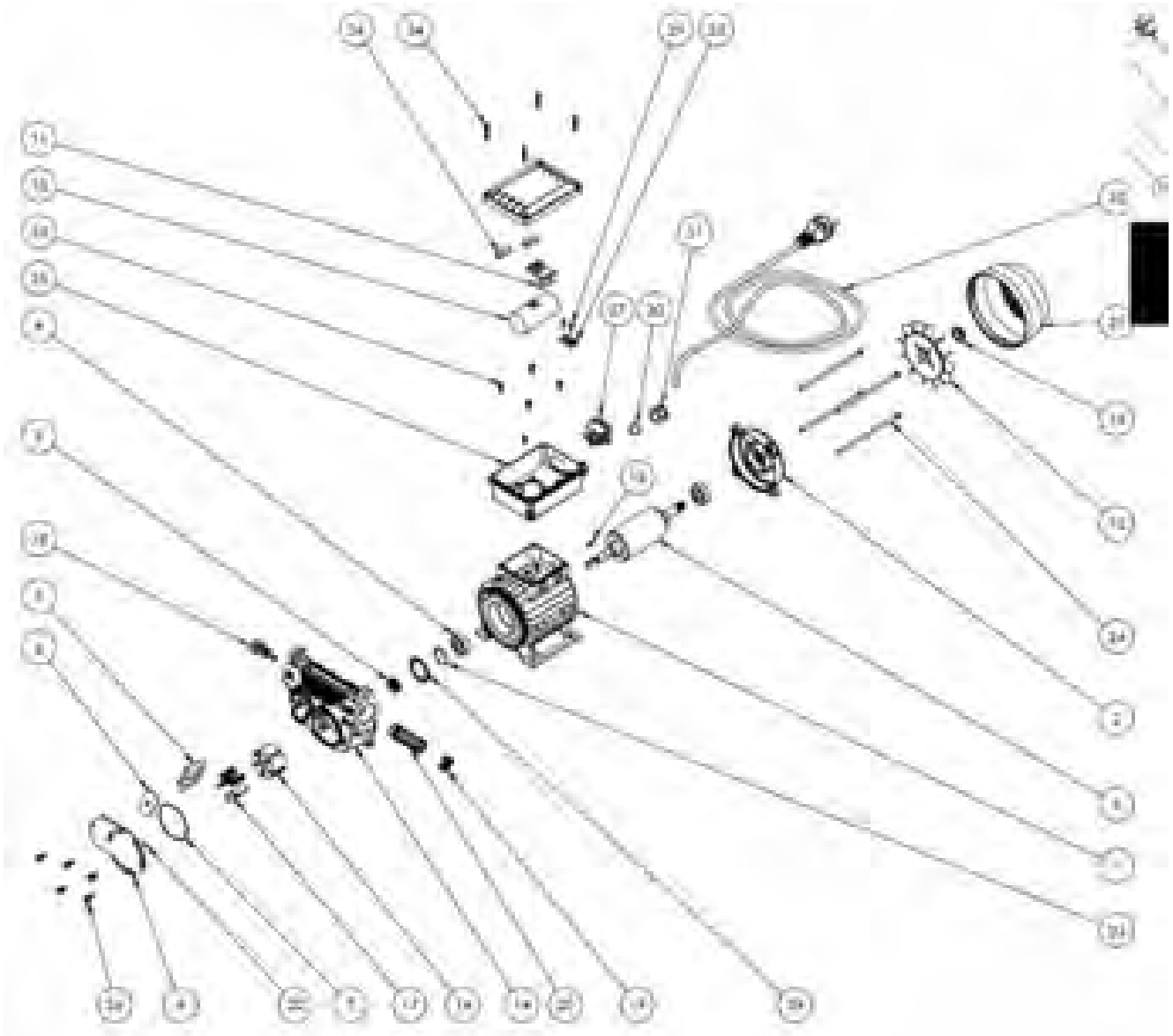

AMB60L

Kit Number	Includes Items
AHFP70LPM-1K	5, 6, 7, 17, 22,
AHFP70LPM-2K Poppet valve kit	18, 19, 20
AHFP-SWITCH	27

Note: For parts not listed above please refer to instruction manual listed on the Macnaught website www.macnaught.com.au

For more product information:

AMB60L
(Page 86)



SERVICE PARTS

AMB100L EXPLODED DIAGRAM

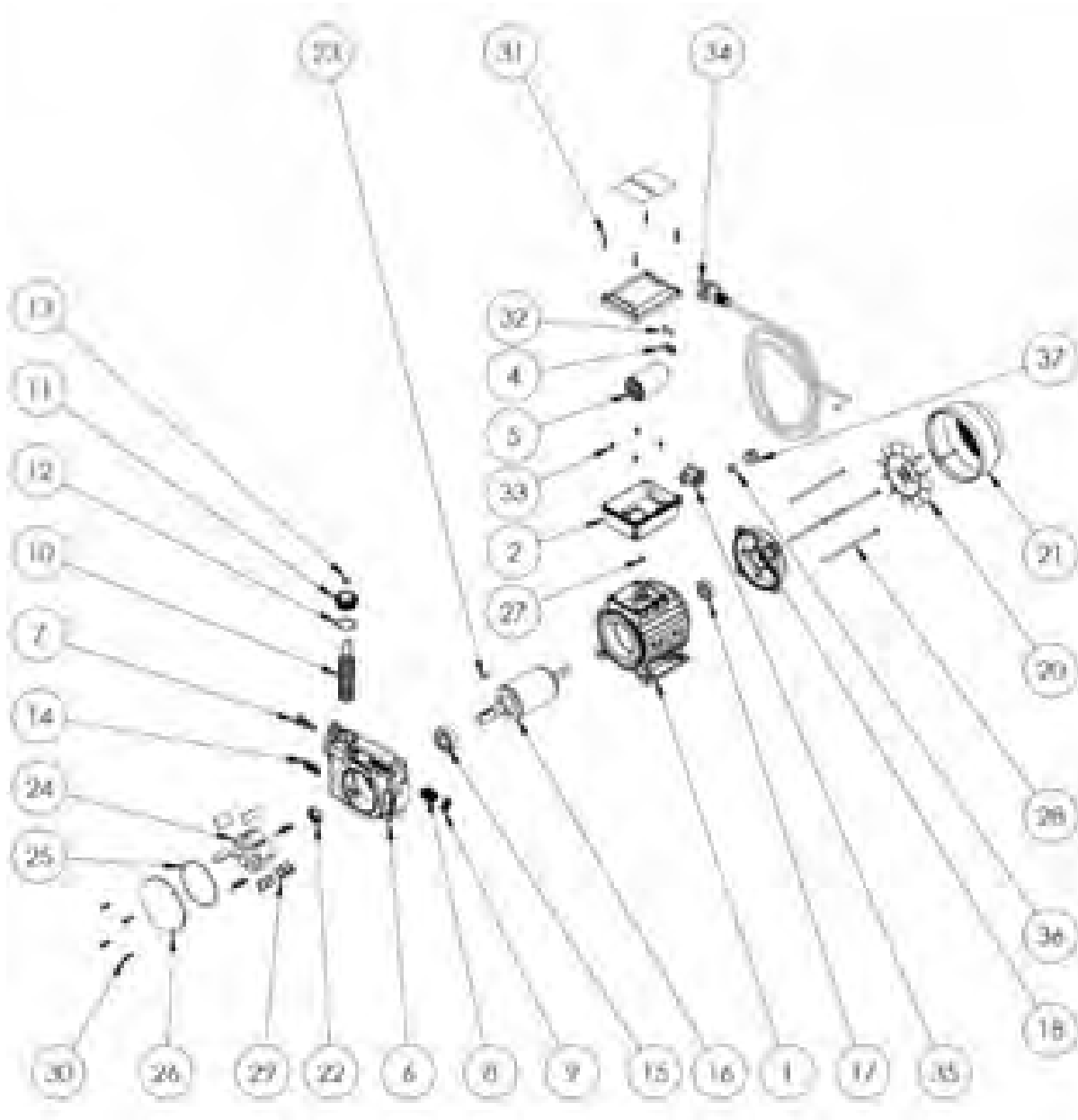

AMB100L	
Kit Number	Includes Items
AHFP100LPM-1K	12, 22, 25, 29
AHFP100LPM-2K Poppet valve kit	7, 8, 9
AHFP-SWITCH	35

Note: For parts not listed above please refer to instruction manual listed on the Macnaught website www.macnaught.com.au

For more product information:



RETRACTA R3 SERIES

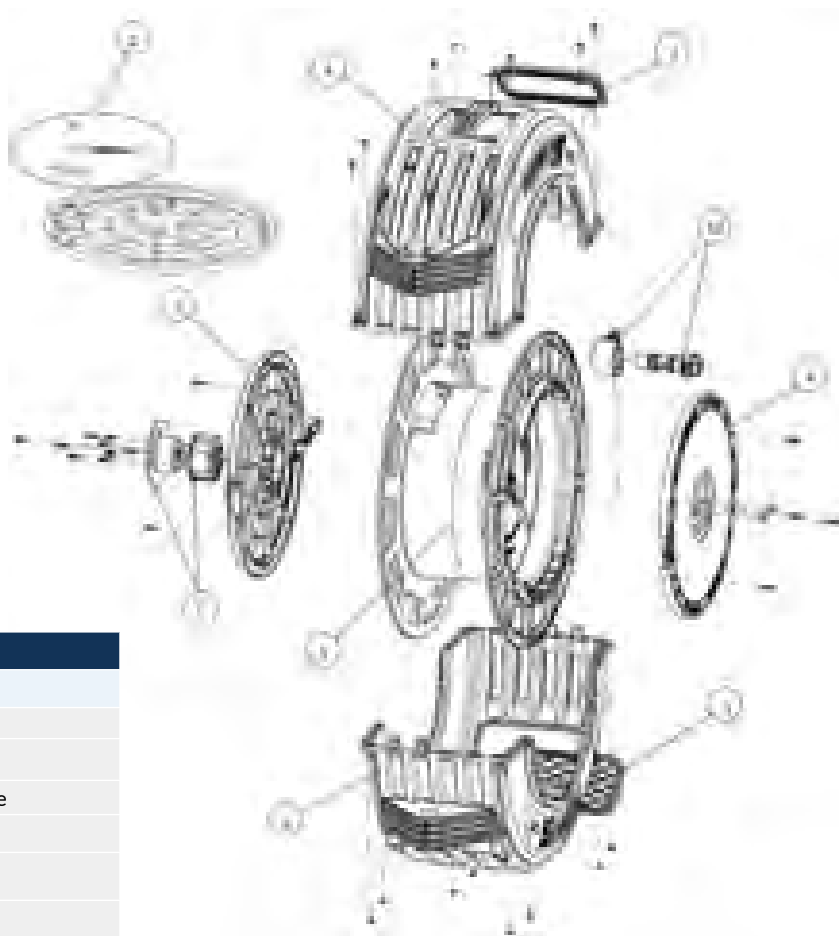

R3 SERIES		
Spare Part Number	Item no	Description
R3THS	1	Tension Hub Set
R3LS	2	Latch Set
R3LPS	3	Latching Side Plate
R3IPS	4	Inlet Side Plate
R3DAS	5	Drum Assembly
R3MS	6	Mouth Set
R3SBS	7	Standard Bracket (including locking plate)
R3OCS-COLOR	8	Outer Casting - Single (nom colour)
R3LIS-COLOR	9	Lower Insert (nom colour)

R3 SERIES SWIVEL ASSEMBLY			
Swivel Kit (BSP)	Swivel Seal Kits	Item no	Description
RS115AS	BS115VS	10	1/2" Air/Water
RS116AS	BS115VS	10	3/8" Air/Water/Coolant
RS117S	BS115VS	10	Oil
RS118S	BS115-1K	10	Cold Water
RS119AS	BS115ES	10	Hot Water
RS1S	BS115-1K	10	Horticultural/Garden
RS67S	BS115VS	10	Weed Pesticide
RS124AS	N/A	10	Grease (complete assembly)
SB6S	N/A	10	Grease (refer to grease swivel assembly drawing)
RS85S	N/A	10	High Pressure Hot Water

Note: For parts not listed above please refer to instruction manual listed on the Macnaught website www.macnaught.com.au

For more product information:



SERVICE PARTS

MACNAUGHT SINGLE PEDESTAL REELS

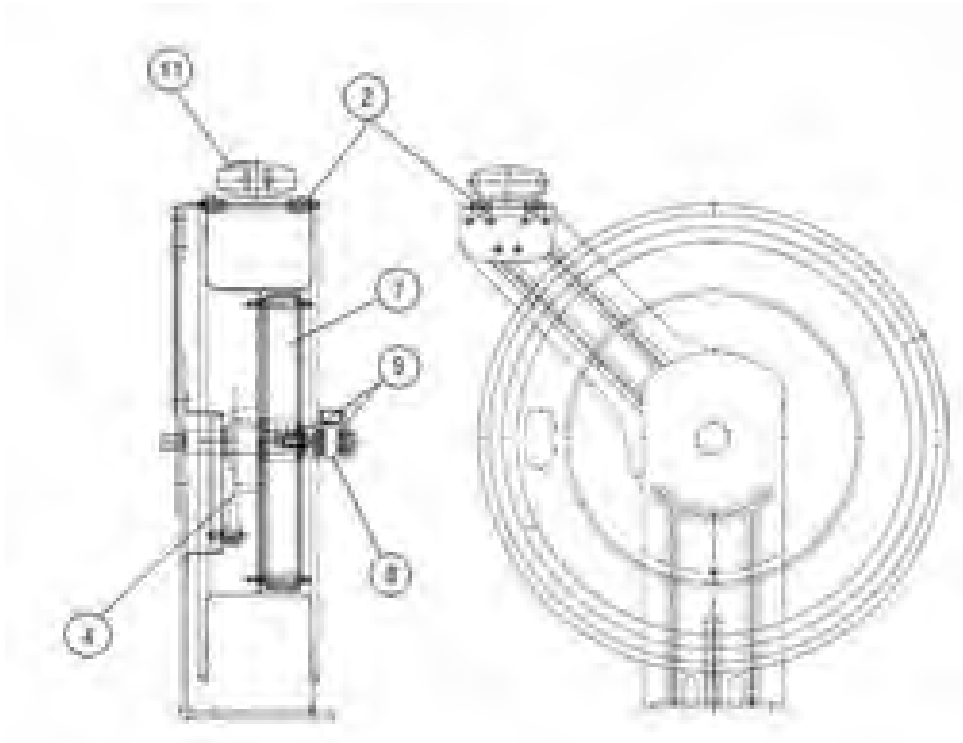

Note: Hose assembly not shown

MACNAUGHT SINGLE PEDESTAL REELS			
Spare Part Number	Item no	No Off	Description
N/A	1	1	Guide Arm and Roller set
SK131S	2	1	Roller Mouth Assembly
N/A	3	1	Support Post
SK133S	4	1	Latch Set
N/A	5	1	Drum Shaft
N/A	6	1	Drum Assembly
SK136S	7	1	Spring Canister
SK136S	8	1	Swivel Assembly (Air/Water) 3/8"
SK139S	8	1	Swivel Assembly (Air/Water/Oil) 1/2"
SK140S	8	1	Swivel Assembly (Grease)
SK141S	9	1	Swivel Seal Set (Air/Water/Oil)
MA142S	10	1	Hose Assembly (Air/Water) 3/8"
SK143S	10	1	Hose Assembly (Air/Water) 1/2"
SK144S	10	1	Hose Assembly (Oil) 1/2"
SK145S	10	1	Hose Assembly (Grease)
SK146S	11	1	Hose Stopper (Air/Water) 3/8"
SK147S	11	1	Hose Stopper (Air/Water/Oil) 1/2"
HPA22SG	11	1	Hose Stopper (Grease)

Note: For parts not listed above please refer to instruction manual listed on the Macnaught website www.macnaught.com.au

For more product information:

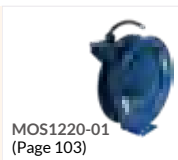

MACNAUGHT TWIN PEDESTAL REELS

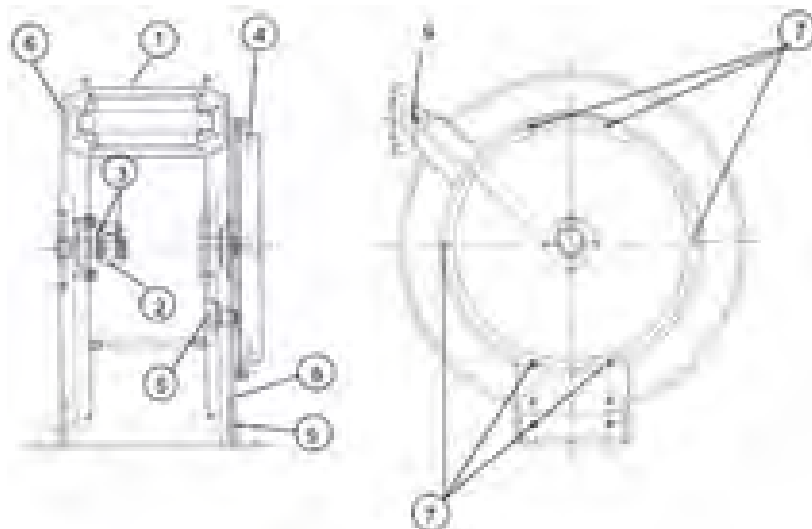

MACNAUGHT TWIN PEDESTAL REELS

Item no	Description	MATP1220	MOTP1220	MATP1920	MOTP1920	MDT2510	MDT2520	MGT0615
1	Roller Guide Set	SKRG1220	SKRG1220	SKRG1920	SKRG1920	SKRG1920	SKRG2520	SKRG0615
2	Swivel Assembly	RHA59S	RHA59S	RHA39S	RHA39S	RHA49S	RHA49S	RHA09S
3	Swivel Seal Set (not shown)	RHA36S	RHA36S	RHA60S	RHA60S	RHA50S	RHA50S	RHA10S
4	Spring Drum Assembly	SKSP1220	SKSP1220	SKSP1920	SKSP1920	SKSP1920	SKSP2520	SKSP0615
5	Latch Set	SK130S	SK130S	SK130S	SK130S	SK130S	SK130S	SK130S
6	Screw and Nut Set	N/A	N/A	N/A	N/A	N/A	N/A	N/A
7	Nut and Bolt	N/A	N/A	N/A	N/A	N/A	N/A	N/A
8	Bolt	N/A	N/A	N/A	N/A	N/A	N/A	N/A
9	Bolt	N/A	N/A	N/A	N/A	N/A	N/A	N/A
10	Hose Assembly (not shown)	HPW41S	HPW41S	HPW61S	HPW61S	POA	HPW51S	HPW11S
11	Hose Stopper (not shown)	RHA42S	RHA42S	RHA62S	RHA62S	RHA62S	RHA52S	RHA12S

MACNAUGHT TWIN PEDESTAL BARE REELS

Item no	Description	MGT0915	MRTTP1320N	MRTTP2520N
1	Roller Guide Set	SKRG0915	SKRG1220	SKRG2520
2	Swivel Assembly	RHA19SG	RHA59S	RHA49S
3	Swivel Seal Set (not shown)	RHA20SG	RHA36S	RHA60S
4	Spring Drum Assembly	SKSP0915	SKSP1220	SKSP2520
5	Latch Set	SK130S	SK130S	SK130S
6	Screw and Nut Set	N/A	N/A	N/A
7	Nut and Bolt	N/A	N/A	N/A
8	Bolt	N/A	N/A	N/A
9	Bolt	N/A	N/A	N/A
10	Hose Assembly (not shown)	HPA21SG	N/A	N/A
11	Hose Stopper (not shown)	HPA22SG	RHA42S	RHA52S

Note: For parts not listed above please refer to instruction manual listed on the Macnaught website www.macnaught.com.au

For more product information:

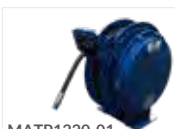

MATP1220-01
(Page 104)



MOTP1920-01
(Page 103)



MDTP2520-01
(Page 103)

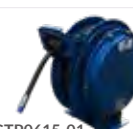

MGT0615-01
(Page 102)

SERVICE PARTS

RETRACTA F SERIES REELS FHGO1915-01

F SERIES SINGLE PEDESTAL REELS			
Spare Part Number	Item no	No Off	Description
SK205S	1	1	Roller Mouth Assembly
SK203S	2	1	Latch Set
SK200S	3	1	Swivel Assembly (Grease)
SK201S	4	1	Swivel Seal Set (Grease)
SK202S	5	1	Hose Stopper (Grease)
RH0915HPS	6	1	Hose Assembly (Grease)
SK204S	7	2	Bearing Set

Note: For parts not listed above please refer to instruction manual listed on the Macnaught website www.macnaught.com.au

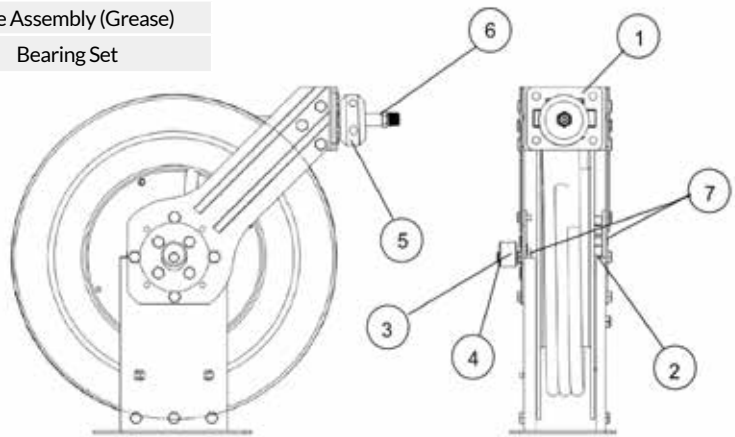

RETRACTA F SERIES REELS FHM1200-01 / FHO1215-01

F SERIES SINGLE PEDESTAL REELS			
Spare Part Number	Item no	No Off	Description
SK205S	1	1	Roller Mouth Assembly
SK203S	2	1	Latch Set
SK210S	3	1	Swivel Assembly (Grease)
SK211S	4	1	Swivel Seal Set (Grease)
RHA42S	5	1	Hose Stopper (Grease)
RH1215S	6	1	Hose Assembly (Grease)
P/A	7	2	Bearing Set

Note: For parts not listed above please refer to instruction manual listed on the Macnaught website www.macnaught.com.au

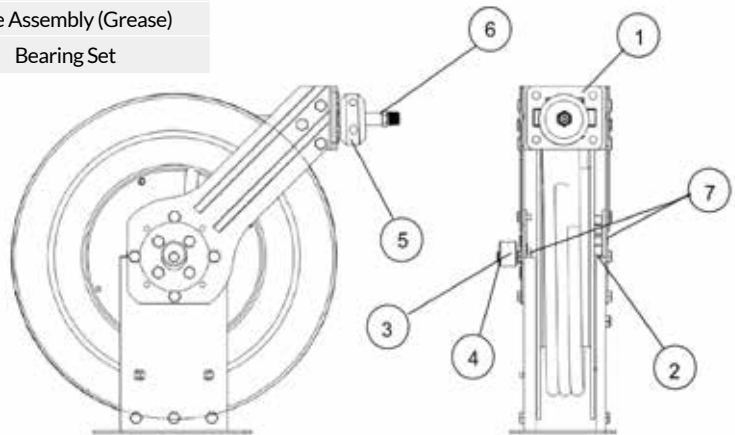

For more product information:



RETRACTA F SERIES REELS

FHM1900-01 / FHO1915-01 / FHA1220-01

F SERIES SINGLE PEDESTAL REELS			
Spare Part Number	Item no	No Off	Description
SK225S	1	1	Roller Mouth Assembly
SK223S	2	1	Latch Set
SK220S	3	1	Swivel Assembly
SK221S	4	1	Swivel Seal Set
RHA62S	5	1	Hose Stopper
RH1915HPS	6	1	Hose Assembly
SK224S	7	2	Bearing Set

Note: For parts not listed above please refer to instruction manual listed on the Macnaught website www.macnaught.com.au

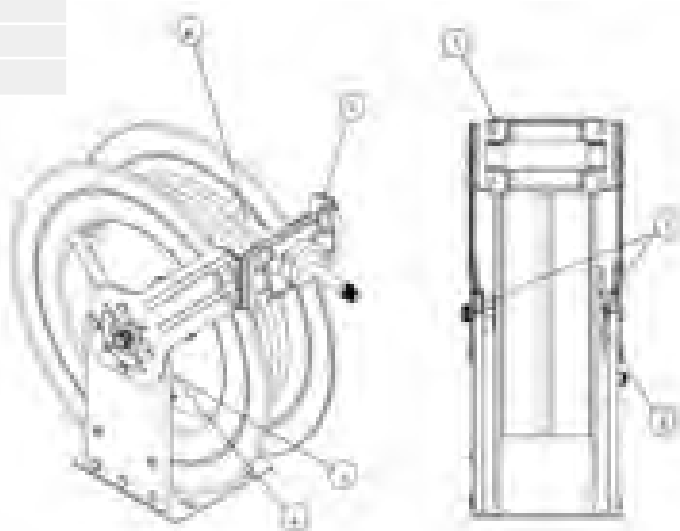

RETRACTA F SERIES REELS

FCM2500-01 / FRM2500-01 / FCD2515-01 / FRD2515-01

FCW2515-01 / FRW2515-01 / FHA1920-01

F SERIES SINGLE PEDESTAL REELS			
Spare Part Number	Item no	No Off	Description
SK235S	1	1	Roller Mouth Assembly
SK233S	2	1	Latch Set
SK230S	3	1	Swivel Assembly (Grease)
SK231S	4	1	Swivel Seal Set (Grease)
RHA52S	5	1	Hose Stopper (Grease)
SK238S	6	1	Hose Assembly (Grease)
SK234S	7	2	Bearing Set

Note: For parts not listed above please refer to instruction manual listed on the Macnaught website www.macnaught.com.au

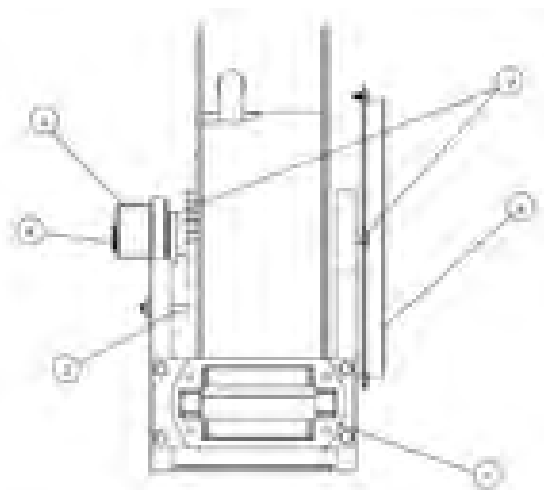

For more product information:



FHO1915-01
(Page 133)



FHM1900-01
(Page 133)



FCD2515-01
(Page 135)



FRW2515-01
(Page 135)

SERVICE PARTS

BATTERY OPERATED PUMPS

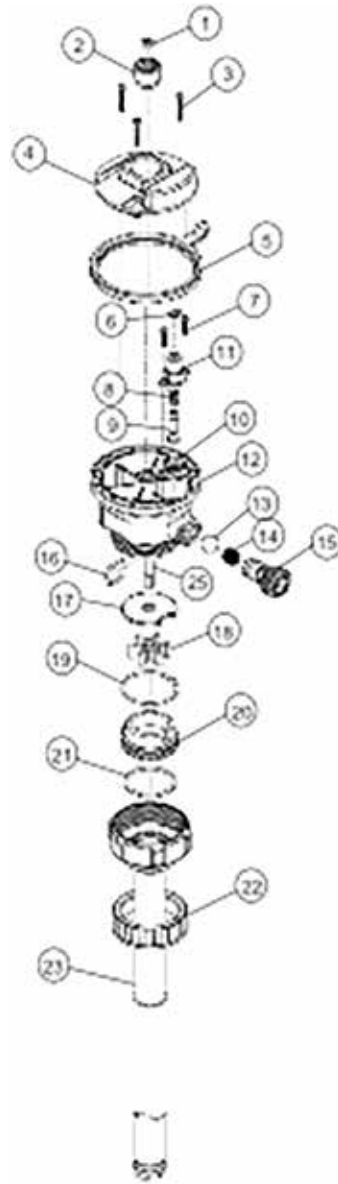

BOP20 AND BOP60	
Kit Number	Includes Items
BOP20-1K Pump seal kit	6, 8, 9, 10, 17, 18, 19, 20, 21
BP-HG	Gun and Hose set
BP20-AK	Bung adaptor set 20ltr
BP60-AK	Bung adaptor set 60ltr
BPB-20AH	Battery
BPC-A	Charger (AUS)
BP20-PH	Power Head

Note: For parts not listed above please refer to instruction manual listed on the Macnaught website www.macnaught.com.au

For more product information:



P58 MAXILUBE® AIR OPERATED PUMP

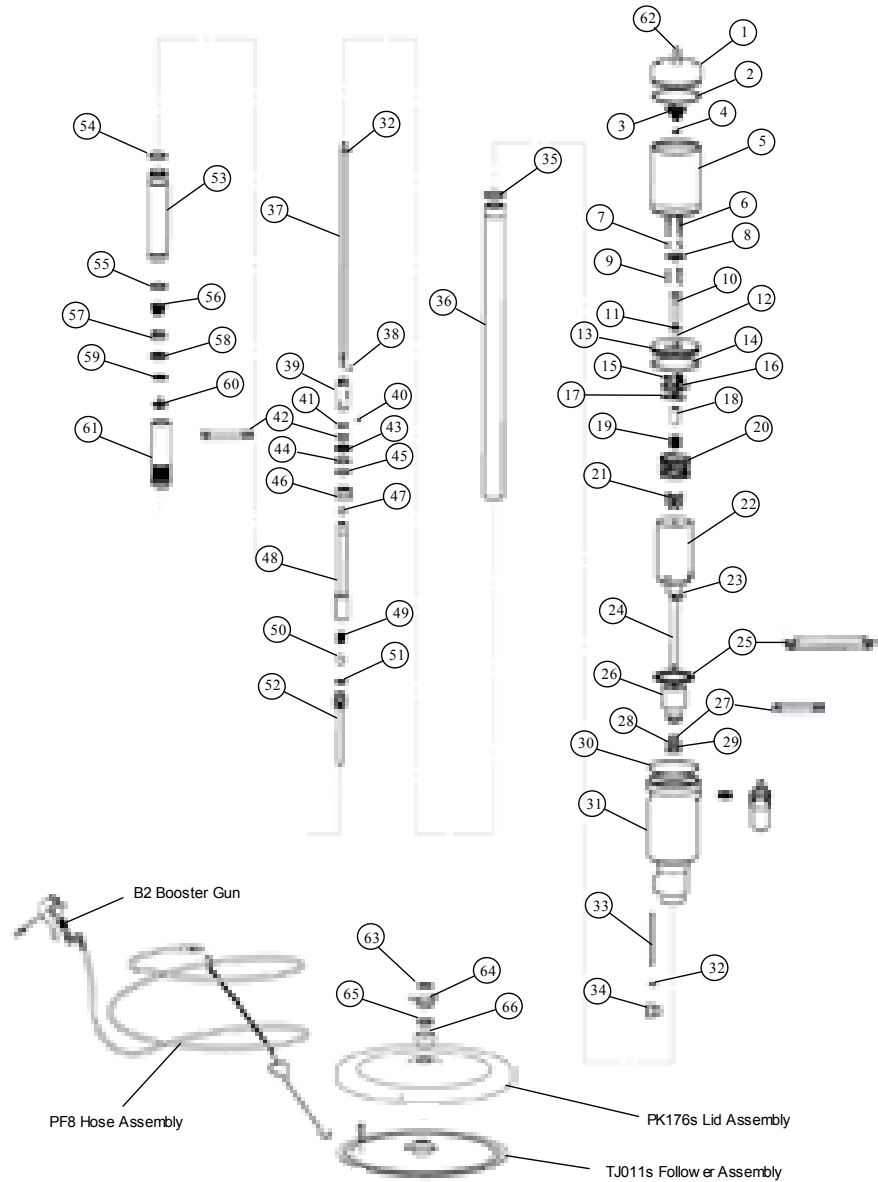

P58 MAXILUBE®	
Kit Number	Includes Items
P58-1K Air Motor Overhaul Kit	2, 6, 7, 8, 9, 10, 11, 12, 13, 14, 15, 16, 17, 18, 19, 20, 21, 25
P58-2K Lower pump Service Kit	27, 28, 29, 32, 35, 38, 40, 41, 42, 43, 44, 45, 46, 47, 49, 50, 51, 52, 54, 55, 56, 57, 58, 59, 60, 63
P58-3K Seal Kit	2, 3, 4, 6, 7, 8, 9, 11, 12, 14, 15, 16, 23, 25, 27, 28, 29, 30, 32, 35, 38, 40, 41, 42, 44, 45, 49, 50, 51, 52, 63

Note: For parts not listed above please refer to instruction manual listed on the Macnaught website www.macnaught.com.au

For more product information:

P58-01
MAXILUBE™
58:1 Ratio Oil
Pump
(Page 23)



P58PLF-01
MAXILUBE™
58:1 Ratio Oil Pump
(Page 23)



PRODUCT CODE INDEX

Product Code	Description	Page
A2H	ALL PURPOSE DRUM PUMP W/ HOSE 60/205L	47
AC26	BUNG ADAPTOR 2" BSP - 2" MAUSER (BLUE)	100
AC27	BUNG ADAPTOR 2" BSP - 2" TRI-SURE (ORANGE)	100
AC28	BUNG ADAPTOR 2" BSP - DIN61 (YELLOW)	100
ACK2-02	ACCESSORY KIT - AVIATION	34
ADTFM	1" TURBINE DIESEL FUEL METER	97
ADTUM	1" TURBINE UREA/DEF METER	97
AFP12A	12V ELECTRIC DIESEL PUMP KIT W/ AUTO NOZZLE	83
AFP12M	12V ELECTRIC DIESEL PUMP KIT W/ MANUAL NOZZLE	83
AFP24A	24V ELECTRIC DIESEL PUMP KIT W/ AUTO NOZZLE	83
AFP24M	24V ELECTRIC DIESEL PUMP KIT W/ MANUAL NOZZLE	83
AHFP100LPM	240V HIGH FLOW DIESEL PUMP	85
AHFP12A	12V HIGH FLOW WALL MOUNT	84
AHFP150LPM	240V HIGH FLOW DIESEL PUMP	85
AHFP70LPM	240V HIGH FLOW DIESEL PUMP	85
AHFP85L-12A	12V HIGH FLOW AUTO DIESEL KIT	84
AMB100L	240V DIESEL MINI BOWSER	86
AMB100L-6M	240V DIESEL MINI BOWSER W 6 METER HOSE	86
AMB60L	240V DIESEL MINI BOWSER - 60LPM	86
AMFM	1" MECHANICAL DIESEL	96
AR320B-01	RETRACTA R3 20M X 3/8" AIR BLUE CASE	113
AR320D-01	RETRACTA R3 20M X 3/8" AIR DARK GREY CASE	113
AR320R-01	RETRACTA R3 20M X 3/8" AIR RED CASE	113
AR415B-01	RETRACTA R3 15M X 1/2" AIR BLUE CASE	113
AR415D-01	RETRACTA R3 15M X 1/2" AIR DARK GREY CASE	113
AR415R-01	RETRACTA R3 15M X 1/2" AIR RED CASE	113
AR420B-01	RETRACTA R3 20M X 1/2" AIR BLUE CASE	113
AR420D-01	RETRACTA R3 20M X 1/2" AIR DARK GREY CASE	113
AR420R-01	RETRACTA R3 20M X 1/2" AIR RED CASE	113
ARC320B-01	RETRACTA R3 20M X 3/8" AIR RACR BLUE CASE	113
ARC320D-01	RETRACTA R3 20M X 3/8" AIR RACR DARK GREY CASE	113
ARC320R-01	RETRACTA R3 20M X 3/8" AIR RACR RED CASE	113
ARC415B-01	RETRACTA R3 15M X 1/2" AIR RACR BLUE CASE	113
ARC415D-01	RETRACTA R3 15M X 1/2" AIR RACR DARK GREY CASE	113
ARC415R-01	RETRACTA R3 15M X 1/2" AIR RACR RED CASE	113
ARC420B-01	RETRACTA R3 20M X 1/2" AIR RACR BLUE CASE	113
ARC420D-01	RETRACTA R3 20M X 1/2" AIR RACR DARK GREY CASE	113
ARC420R-01	RETRACTA R3 20M X 1/2" AIR RACR RED CASE	113
ARG220D-04	RETRACTA R3 20M X 5MM ARGON GREY CASE	126
ARGC220D-04	RETRACTA R3 20M X 5MM ARGON RACR GREY CASE	126
ASB1925	SWIVEL 3/4"BSPT M X 1"BSPT F	189
ATS205	TELESCOPIC SUCTION TUBE	100
AUP240	240V UREA/DEF UREA PUMP KIT	87
AW315B-01	RETRACTA R3 15M X 3/8" AIR/WATER BLUE CASE	115

AW320B-01	RETRACTA R3 20M X 3/8" AIR/WATER BLUE CASE	115
AW415B-01	RETRACTA R3 15M X 1/2" AIR/WATER BLUE CASE	115
AW420B-01	RETRACTA R3 20M X 1/2" AIR/WATER BLUE CASE	115
B2	BOOSTER GUN ASSY W/O SWIVEL	39
B2-01	BOOSTER GUN ASSY	39
B2-1K	SERVICE KIT B2/B3	39
B2-SG	BOOSTER GUN W/ Z SWIVEL	39
B3	B3 CONTROL GUN (NON-BOOSTING)	39
B3-01	NON-BOOSTING GUN W/ ZSB SWIVEL	39
BP20-PH	BOP POWERHEAD	41
BP20S-OHA	BOP20 - STARTER KIT - HIGH VISCOSITY	40
BP20S-OLA	BOP20 - STARTER KIT	40
BP20X-ALA	BOP20 - PUMP STEM KIT- 20L - ATF	41
BP20X-COA	BOP20 - PUMP STEM KIT - 20L - COOLANT	41
BP20X-OHA	BOP20 - PUMP STEM KIT - HIGH VISCOSITY	41
BP20X-OLA	BOP20 - PUMP STEM KIT	41
BP60S-OHA	BOP60 - STARTER KIT - HIGH VISCOSITY	42
BP60S-OLA	BOP60 - STARTER KIT	42
BP60X-ALA	BOP60 - PUMP STEM KIT - ATF	43
BP60X-OHA	BOP60 - PUMP STEM KIT - HIGH VISCOSITY	43
BP60X-OLA	BOP60 - PUMP STEM KIT	43
BPB-20AH	BOP 2.0AH BATTERY	41
BPC-A	BOP CHARGER AU	41
C11-01	MANUAL LEVER OIL PUMP	48
C16-01	SUCTION GUN 500ml	46
C7-01	MANUAL OIL PUMP 20/25L	44
C7-51	MANUAL OIL PUMP - ATF STRAINER 20/25L	44
C7N-01	MANUAL OIL PUMP W/O HOSE	44
C7Z-01	MANUAL ZINC OIL PUMP 20/25L	44
CCG-01	COOLANT CONTROL NOZZLE	67
CF	FILTER ASSEMBLY-160 MICRON	76
CL315B-01	RETRACTA R3 15M X 3/8" COOL BLUE CASE	129
CL320D-01	RETRACTA R3 20M X 3/8" COOL DARK GREY CASE	129
CLC320D-01	RETRACTA R3 20M X 3/8" COOL RACR DARK GREY CASE	129
CW415B-01	RETRACTA R3 15M X 1/2" COLD W BLUE CASE	117
CW420B-01	RETRACTA R3 20M X 1/2" COLD W BLUE CASE	117
CWC415B-01	RETRACTA R3 15M X 1/2" COLD W RACR BLUE CASE	117
CWC420B-01	RETRACTA R3 20M X 1/2" COLD W RACR BLUE CASE	117
DDP13	1/2" DIAPHRAGM PUMP - POLY	89
DDP19	3/4" DIAPHRAGM PUMP-ALUM/POLY	89
DDP25	1" DIAPHRAGM PUMP-ALUM/POLY	89
DDP38	1.5" DIAPHRAGM PUMP-ALUMINIUM	89
DDP50	2" DIAPHRAGM PUMP-ALUMINIUM	89
DH-01	CONNECTOR KIT	100
DM100-01	1" MECHANICAL FUEL METER	96
DR418G-03	RETRACTAFLEX R3 18M X 1/2" GARDEN GREEN CASE	119

PRODUCT CODE INDEX

DR418P-03	RETRACTAFLEX R3 18M X 1/2" GARDEN BEIGE CASE	119
DRC418G-03	RETRACTAFLEX R3 18M X 1/2" GARDEN RACR GREEN CASE	119
DRC418P-03	RETRACTAFLEX R3 18M X 1/2" GARDEN RACR BEIGE CASE	119
DV-01	CONNECTOR KIT	100
ESAW1015-01	E-SERIES ENCLOSED METAL 15M x 3/8" AIR HOSE	138
ESAW1210-01	E-SERIES ENCLOSED METAL 10M x 1/2" AIR HOSE	138
ESGR0610-01	E-SERIES ENCLOSED METAL 10M x 1/4" GREASE HOSE	138
ESO1210-01	E-SERIES ENCLOSED METAL 10M x 1/2" OIL HOSE	138
EACTR-LM	4 WAY EVACUATION KIT - LUBEMATE™	161
EACTR-MC	4 WAY EVACUATION KIT - MACNAUGHT	91
FB2-450	FLEXILUBE GREASE - 450g CARTRIDGE	38
FCD2515-01	F-SERIES 1" DIESEL REEL W/ 15M HOSE	135
FCD3815-02	F-SERIES 1 1/2" DIESEL REEL W/ 15M HOSE	135
FCM2500-01	F-SERIES 1" OIL/WATER /AIR REEL- BARE REEL	135
FCM3800-02	F-SERIES 1 1/2" OIL /WATER/AIR REEL - BARE REEL	135
FCW2515-01	F-SERIES 1" WATER REEL W/ 15M HOSE	135
FCXD2515-01	F-SERIES METERED 1" DIESEL REEL W/ 15M HOSE	137
FCXD3815-02	F-SERIES METERED 1 1/2"DIESEL REEL W/ 15M HOSE	137
FGK1-01	FLEXILUBE GREASING KIT	15
FGK1-02	FLEXILUBE GREASING KIT - K32 IN CASE W/ ACCESSORIES	15
FHA1220-01	F-SERIES 1/2" AIR/WATER REEL W/ 20M HOSE	133
FHA1920-01	F-SERIES 3/4" AIR/WATER REEL W/ 20M HOSE	135
FHG0915-01	F-SERIES 3/8" GREASE REEL W/ 15M HOSE	133
FHM1200-01	F-SERIES 1/2" OIL/WATER/AIR REEL - BARE REEL	133
FHM1900-01	F-SERIES 3/4" OIL/WATER/AIR REEL - BARE REEL	133
FHO1215-01	F-SERIES 1/2" OIL REEL W/ 15M HOSE	133
FHO1915-01	F-SERIES 3/4" OIL REEL W/ 15M HOSE	133
FHXO1215-01	F-SERIES 1/2" OIL REEL W/ 15M HOSE	136
FHXO1915-01	F-SERIES METERED 3/4" OIL REEL W/ 15M HOSE	136
FRAS415D-01	RETRACTA R3 15M x 1/2" F.R.A.S GREY CASE	130
FRD2515-01	F-SERIES 1" DIESEL REEL W/ 15M HOSE (HR FRAME)	135
FRD3815-02	F-SERIES 1 1/2" DIESEL REEL W/ 15M HOSE (HR FRAME)	135
FRM2500-01	F-SERIES 1" OIL/WATER /AIR REEL-BARE REEL(HR FRAME)	135
FRM3800-02	F-SERIES 1 1/2" OIL /WATER/AIR REEL-BARE REEL (HR FRAME)	135
FRW1920-01	F-SERIES 3/4" WATER REEL W/ 20M HOSE (HR FRAME)	135
FRW2515-01	F-SERIES 1" WATER REEL W/ 15M HOSE (HR FRAME)	135
GFU	GREASE FITTING UNBLOCKER	38
GR210B-01	RETRACTA R3 10M X 1/4" GREASE BLUE CASE	123
GR215D-01	RETRACTA R3 15M X 1/4" GREASE DARK GREY CASE	123
GR215K-01	RETRACTA R3 15M X 1/4" GREASE BLACK CASE	123
GRC215D-01	RETRACTA R3 15M X 1/4" GREASE RACR DARK GREY CASE	123
GRC215K-01	RETRACTA R3 15M X 1/4" GREASE RACR BLACK CASE	123
GS100-01	180KG GREASE SYSTEM COMPLETE KIT	29
GT-01	RAPID-FLO ROTARY FUEL PUMP	78
GT-01-BD	RAPID-FLO "BIODIESEL"	78
GT-01/WRENCH	GT KIT INCLUDING DRUM WRENCH AND FUEL FILTER	78

GTF-01	RAPID-FLO ROTARY FUEL PUMP W FILTER	78
GTFM-01	RAPID-FLO ROTARY FUEL PUMP W FILTER & METER	78
HA-01	10 MICRON FUEL FILTER	100
HA1S-01	10 MICRON FUEL FILTER - 1"BSP	100
HA1SS80	80 MESH FILTER ASSY - 1"BSP	100
HA7S	FILTER ELEMENT-10 MICRON	100
HAB1908-01	RETRACTA OPEN 8M X 3/4" ADBLUE	139
HASS40S	STRAINER ELEMENT KIT-40 MESH	100
HASS80S	STRAINER ELEMENT KIT-80 MESH	100
HG100-01	HI FLO GUN W/ FLEX EXT	71
HG100-01-11	HI FLO GUN W/ FLEX EXT - ZINC	71
HG100-019E-01	HI FLOW GUN W/ ELECT METER	71
HG100-019E-02	HI FLOW GUN W/ ELECT METER - NPT	71
HG100-02	HI FLO GUN W/ FLEX EXT - NPT	71
HG20F-01	CONTROL GUN W/ FLEX	67
HG20F-012E-01	CONTROL GUN W/ ELECTRIC METER	69
HG20F-012E-02	CONTROL GUN W/ ELECTRIC METER - NPT	69
HG20F-012M-01	CONTROL GUN W/ MECHANICAL METER	69
HG20F-02	CONTROL GUN W/ FLEX - NPT	67
HG20R-01	NOZZLE-BSP(RIGID EXTENSION LATCHING)	67
HG20R-012E-01	CONTROL GUN W/ ELECTRIC METER	69
HG20R-012E-02	CONTROL GUN W/ ELECTRIC METER - NPT	69
HG20R-02	NOZZLE-NPT(RIGID EXTENSION LATCHING)	67
HG40-01	CONTROL GUN W/ MECHANICAL METER	73
HG40-02	CONTROL GUN W/ MECHANICAL METER - NPT	73
HG55-01	CONTROL GUN W/ ELECTRIC METER	73
HG55-02	CONTROL GUN W/ ELECTRIC METER - NPT	73
HG60-01	CONTROL GUN W/ PRESET ELECTRIC	73
HG60-02	CONTROL GUN W/ PRESET ELECTRIC - NPT	73
HGFEX	FLEXIBLE EXTENSION - NO NOZZLE	76
HGFFNZ	FLEXIBLE EXTENSION - AUTO NOZZLE	77
HGFNZ	FLEXIBLE EXTENSION	76
HGMNZL	MANUAL NON-DRIP NOZZLE	76
HGNZL	AUTOMATIC NON-DRIP NOZZLE	76
HGREX	RIGID EXTENSION - NO NOZZLE	76
HGRNZ	RIGID EXTENSION W/ NON-DRIP NOZZLE	76
HNU	NOZZLE FOR HP PUMP	100
HP320R-01	RETRACTA R3 20M X 3/8" HIGH PRESSURE WASH RED CASE	118
HPC320R-01	RETRACTA R3 20M X 3/8" HIGH PRESSURE WASH RACR RED CASE	118
HW415R-01	RETRACTA R3 15M X 1/2" HOT W RED CASE	116
HW420R-01	RETRACTA R3 20M X 1/2" HOT W RED CASE	116
HWC415R-01	RETRACTA R3 15M X 1/2" HOT W RACR RED CASE	116
HWC420R-01	RETRACTA R3 20M X 1/2" HOT W RACR RED CASE	116
IM012E-01	ELECTRONIC OIL METER - 1/2"BSP	75
IM012E-02	ELECTRONIC OIL METER - 1/2" - NPT	75
IM012M-01	MECHANICAL OIL METER - 1/2"BSP	75

PRODUCT CODE INDEX

IM012M-02	MECHANICAL OIL METER - 1/2" - NPT	75
IM012P-01	PULSE OIL METER - 1/2"BSP	75
IM012P-02	PULSE OIL METER - 1/2" - NPT	75
IM019E-01	ELECTRONIC OIL METER - 3/4"BSP	75
IM019E-02	ELECTRONIC OIL METER - 3/4" - NPT	75
IM019P-01	PULSE OIL METER - 3/4"BSP	75
IM019P-02	PULSE OIL METER - 3/4" - NPT	75
J3-01	MANUAL GREASE TRANSFER PUMP	19
J65	ADAPTOR ASSEMBLY	38
K29-01	FLEXIGUN® 450G - PISTOL GRIP	15
K29-01-11	FLEXIGUN® 450G ZINC	15
K29-12	FLEXIGUN® 450G - CASE KIT	15
K32-01	FLEXIGUN® 400G	15
K4-01	SUPERLUBE™ GREASE PUMP	19
K40-01	LEVERGUN® 400G	16
K45-01	LEVERGUN® 450G	16
K45-01-11	LEVERGUN® ZINC 450g	16
K53-01	POWERPISTOL™ 450G	17
K7-01	MINILUBE® 2.5KG	21
K7-24	MINILUBE® 2.5KG	21
K7-67	MINILUBE® 5KG	21
KDA	SNAP-ON ADAPTOR	38
KDE8	QUICK CONNECT RIGID EXTENSION	37
KDF13	QUICK CONNECT FLEXIBLE	37
KDF21	QUICK CONNECT FLEXIBLE	36
KDN	QUICK CONNECT 90° NEEDLE	36
KDR	QUICK CONNECT 90° COUPLER	36
KF17	FLEXIBLE HOSE 450MM	37
KF30	FLEXIBLE HOSE 760MM	37
KF300-1K	400G BARREL CONVERSION KIT	39
KF9	FLEXIBLE HOSE-300mm	37
KFR	RIGID FLEXIBLE EXTENSION	37
KGR	GIANT BUTTON HEAD COUPLER 7/8"	38
KIN	INJECTOR NEEDLE (ACCESSORY)	37
KR	PRESSURITE™ GUN	38
KSR	STANDARD BUTTON HEAD COUPLER	38
KT5	2.5Kg CONTAINER (ACCESSORY)	38
KT6	5Kg CONTAINER (ACCESSORY)	38
KY	SUPERGRIP™ COUPLER	39
KY-10	SUPERGRIP™ COUPLER (10PCK)	39
KY-50	SUPERGRIP™ COUPLER (50PCK)	39
KY-N	SUPERGRIP™ COUPLER NPT	39
KY2P	SUPERGRIP™ COUPLER TWIN PACK	39
KYPLUS-01	KYPLUS GREASE COUPLER BSP	31
KYPLUS-01-10	KYPLUS GREASE COUPLER BSP (Counter Display - 10s Pack)	31
KYPLUS-01TP	KYPLUS Grease Coupler BSP (Trade Pack - 10 units)	31

KYPLUS-01TP-100	KYPLUS Grease Coupler BSP (Trade Pack - 100 units)	31
KYPLUS-02	KYPLUS GREASE COUPLER NPT	31
KYPLUS-02-10	KYPLUS GREASE COUPLER NPT (Counter Display - 10s Pack)	31
KYPLUS-02TP	KYPLUS Grease Coupler NPT (Trade Pack - 10 units)	31
KYPLUS-02TP-100	KYPLUS Grease Coupler NPT (Trade Pack - 100 units)	31
KYPLUS-03	KYPLUS GREASE COUPLER M10	31
KYPLUS-03-10	KYPLUS GREASE COUPLER M10 (Counter Display - 10s Pack)	31
KYPLUSXL-01	KYPLUSXL GREASE COUPLER BSP	33
KYPLUSXL-01-10	KYPLUSXL GREASE COUPLER BSP (Counter Display - 10s Pack)	33
KYPLUSXL-02	KYPLUSXL GREASE COUPLER NPT	33
KYPLUSXL-02-10	KYPLUSXL GREASE COUPLER NPT (Counter Display - 10s Pack)	33
KYPLUSXL-03	KYPLUSXL GREASE COUPLER M10	33
KYPLUSXL-03-10	KYPLUSXL GREASE COUPLER M10 (Counter Display - 10s Pack)	33
KZD	NEEDLEPOINT COUPLER(Accessory)	36
KZDXL	LONG STRAIGHT NEEDLE COUPLER	36
KZE	CONCAVE NIPPLE COUPLER	36
KZHY	LONG HYPODERMIC NEEDLE POINT	36
KZLN45	NEEDLEPOINT COUPLER 300mm X 45°	36
KZLNJ	NEEDLEPOINT COUPLER 300mm X "J"	36
KZLNR	NEEDLEPOINT COUPLER 300mm X 90°	36
KZLNS	300mm LONG NEEDLE POINT COUPLE	36
KZSNR	SHORT 90° ANGLE COUPLER	36
KZX	CONCAVE NIPPLE COUPLER	38
L-AG450	AIR OPERATED GREASE GUN-450gm	146
L-ANHF	HI-FLO FUEL NOZZLE AUTO LATCH	187
L-ARPD1	AIR OPERATED 1:1 OIL PUMP	158
L-ARPD1-KIT1	OIL BAR TAP+PUMP KIT-1:1 RATIO	163
L-ARPD3	3:1 RATIO OIL PUMP - DRUM/205L	158
L-ARPD3-KIT2	3:1 RATIO OIL PUMP W/ HOSE	159
L-ARPD3-KIT3	PUMP & HOSE ASSEMBLY W/ GUN	159
L-ARPD3-KIT5	L-ARPD3 W/ HOSE, PREMIUM DIGITAL OIL GUN AND DRUM WRENCH	160
L-ARPD3-KIT6	L-ARPD3 W/ HOSE, PRESET DIGITAL OIL GUN AND DRUM WRENCH	160
L-ARPT-1	L-ARPD3 W/ HOSE, DIGITAL OIL GUN&205L DRUM TROLLEY	163
L-ARPTR-1	L-ARPD3 W/ RETRACTA OIL REEL DIGITAL OIL GUN&DRUM TROLLEY	163
L-ASFL	LARGE ANTI SPILL FUNNEL - 3.5L	177
L-ASFS	SMALL ANTI SPILL FUNNEL - 1.7L	177
L-AWS1015	LUBEMATE™ 3/8" X 15M SINGLE PEDESTAL AIR/WATER REEL	196
L-AWS1215	LUBEMATE™ 1/2" X 15M SINGLE PEDESTAL AIR/WATER REEL	196
L-AWTP1015	LUBEMATE™ 3/8" X 15M TWIN PEDESTAL AIR /WATER REEL	197
L-AWTP1215	LUBEMATE™ 1/2" X 15M TWIN PEDESTAL AIR/ WATER REEL	197
L-AWTP1920	LUBEMATE™ 3/4" X 20M TWIN PEDESTAL AIR/WATER REEL	198
L-BDP205L	19.2V BATTERY DRUM PUMP 205L	180
L-BG18V	BATTERY GREASE GUN 450G - 18V	148
L-BG18VLI	LUBEMATE™ LI-ION BATTERY GREASE	147
L-BGB	LUBEMATE™ BATTERY GREASE GUN BATTERY	148
L-BGBLI	LUBEMATE™LI-ION BATTERY	147

PRODUCT CODE INDEX

L-BGC	LUBEMATE™ BATTERY GREASE GUN CHARGER	148
L-BGCLI	LUBEMATE™ LI-ION CHARGER	147
L-BH1418N	BUTTONHEAD FITTING 1/4"NPT	153
L-BH1418N-B	BUTTONHEAD FITTING 1/4"NPT	153
L-BH1419B	BUTTONHEAD FITTING 1/4"BSP	153
L-BH1419B-B	BUTTONHEAD FITTING 1/4"BSP	153
L-BH1827N	BUTTONHEAD FITTING 1/8"NPT	153
L-BH1827N-B	BUTTONHEAD FITTING 1/8"NPT	153
L-BH1828B	BUTTONHEAD FITTING 1/8"BSP	153
L-BH1828B-B	BUTTONHEAD FITTING 1/8"BSP	153
L-BLPH	BI-LOBE PUMP W/ HOSE	178
L-BLPH-KIT	BI-LOBE PUMP W/ HOSE & HA-01 FILTER KIT	178
L-BLPHFM	BI-LOBE PUMP W/ HOSE & HA-01 FILTER KIT & METER	178
L-BOP-5	BATTERY OPERATED PUMP	181
L-C4	4 JAW COUPLER 1/8"BSP	151
L-DDP13	1/2"AIR OPERATED DIAPHRAGM PUMP	188
L-DDP19	3/4"AIR OPERATED DIAPHRAGM PUMP	188
L-DDP25	1" AIR OPERATED DIAPHRAGM PUMP	188
L-DHFOG	HIGH FLOW DIGITAL OIL GUN W/ RIGID EXT AUTO NOZZLE	171
L-DOBTP	DIGITAL OIL TRANSFER TAP PUMP MOUNT	172
L-DOGFA	DIGITAL OIL CONTROL GUN W/ FLEX EXT AND AUTO NOZZLE	166
L-DOGRM	DIGITAL OIL CONTROL GUN W/ RIGID EXT AND MAN NOZZLE	166
L-DOM35-01	DIGITAL OIL METER 1/2" 1500PSI	173
L-DOM35-02	DIGITAL OIL METER 1/2" 750PSI	173
L-DOM80-01	DIGITAL OIL METER 3/4" 750PSI	173
L-DP20J	20L OIL DRUM PUMP	155
L-DP20P	20L PREMIUM OIL PUMP	155
L-DPOCG	DIGITAL PRESET OIL CONTROL GUN	165
L-DT205	205L DRUM DOLLY	177
L-DT2060	DRUM TROLLEY-20L / 60L	177
L-DTFM	1" DIGITAL TURBINE	185
L-DTP2	2" DRUM FAUCET	177
L-DTP2515	1" X 15M TWIN PEDESTAL DIESEL /AIR/WATER REEL	198
L-DTUM	1" DIGITAL TURBINE UREA/DEF	194
L-DWA	DRUM WRENCH ALUM 2"-3/4"	177
L-FEXA	FLEX EXT AUTO 1/2"	177
L-FM25	MECHANICAL DIESEL METER 1"	185
L-FNAD	AUTOMATIC DIESEL NOZZLE	187
L-FNADP	AUTO DIESEL NOZZLE PREMIUM 60 LPM	187
L-FNAU	AUTOMATIC UNLEADED NOZZLE	187
L-FNMD	MANUAL DIESEL NOZZLE	187
L-FNMU	MANUAL UNLEADED NOZZLE	187
L-FOFL	FUEL & OIL (TRACTOR FUNNEL)	189
L-FPA12V	12VOLT ELECTRIC FUEL PUMP	182
L-FPM12V	12V ELECTRIC FUEL PUMP KIT	182
L-FS19	SWIVEL 3/4"	189

L-FS25	SWIVEL 1"	189
L-FX12	FLEXIBLE HOSE EXTENSION-300mm	151
L-FX18	FLEXIBLE EXTENSION-450mm	151
L-GCV	GREASE CONTROL VALVE	151
L-GFTT	GREASE FITTING THREAD TESTER	151
L-GK180	AIR-OPERATED GREASE PUMP KIT	149
L-GK180TROLLEY	180KG GREASE PUMP KIT W/ TROLLEY	149
L-GK20	AIR-OPERATED GREASE PUMP KIT	149
L-GK20TROLLEY	20KG GREASE PUMP KIT W/ TROLLEY	149
L-GS0615	1/4" X 15M SINGLE PEDESTAL GREASE REEL	196
L-GS1015	3/8" X 15M SINGLE PEDESTAL GREASE REEL	196
L-GTP0615	1/4" X 15M TWIN PEDESTAL GREASE REEL	197
L-GTP1015	3/8" X 15M TWIN PEDESTAL GREASE REEL	197
L-HFFPA12V	12V HIGH FLOW FUEL PUMP KIT	183
L-HFFPM12V	12V HIGH FLOW FUEL PUMP KIT	183
L-HFOG	HIGH FLOW OIL CONTROL GUN W/ FLEX EXT AUTO NOZZLE	170
L-HMBA240V	240V AUTO MINI-BOWSER PUMP ASSY	184
L-J2L	2 LITRE PLASTIC MEASURING JUG	177
L-J5L	5 LITRE PLASTIC MEASURING JUG	177
L-J6L	6 LITRE PLASTIC MEASURING JUG	177
L-J8L	8 LITRE PLASTIC MEASURING JUG	177
L-LBP	LEVER ACTION BARREL PUMP ASSY	156
L-LG450	LEVER GREASE GUN - 450G	145
L-MACP200	ROTARY AD-BLUE CHEMICAL	191
L-MOGF	METERED OIL CONTROL GUN	169
L-MPG	MINI PISTOL GREASE GUN	145
L-MTA	UREA/DEF MAGNETIC TANK ADAPTOR	195
L-N061M-0	GREASE NIPPLE-M6 x 1 STRAIGHT	152
L-N061M-0-B	GREASE NIPPLE-M6 x 1 STRAIGHT	152
L-N061M-45	GREASE NIPPLE-M6 x 1 45°	153
L-N061M-45-B	GREASE NIPPLE-M6 x 1 45°	153
L-N061M-90	GREASE NIPPLE-M6 x 1 90°	152
L-N061M-90-B	GREASE NIPPLE-M6 x 1 90°	152
L-N08125M-0	GREASE NIPPLE-M8x1.25 STRAIGHT	152
L-N08125M-0-B	GREASE NIPPLE-M8x1.25 STRAIGHT	152
L-N081M-0	GREASE NIPPLE-M8 x 1 STRAIGHT	152
L-N081M-0-B	GREASE NIPPLE-M8 x 1 STRAIGHT	152
L-N081M-45	GREASE NIPPLE-M8 x 1 45°	153
L-N081M-45-B	GREASE NIPPLE-M8 x 1 45°	153
L-N081M-90	GREASE NIPPLE-M8 x 1 90°	152
L-N081M-90-B	GREASE NIPPLE-M8 x 1 90°	152
L-N1015M-0	GREASE NIPPLE-M10x1.5 STRAIGHT	152
L-N1015M-0-B	GREASE NIPPLE-M10x1.5 STRAIGHT	152
L-N101M-0	GREASE NIPPLE-M10 x 1 STRAIGHT	153
L-N101M-0-B	GREASE NIPPLE-M10 x 1 STRAIGHT	153
L-N101M-OSS	GREASE NIPPLE-M10 x 1 STRAIGHT	152

PRODUCT CODE INDEX

L-N101M-OSS-B	GREASE NIPPLE-M10 x 1 STRAIGHT	152
L-N101M-45	GREASE NIPPLE-M10 x 1 45°	153
L-N101M-45-B	GREASE NIPPLE-M10 x 1 45°	153
L-N101M-90	GREASE NIPPLE-M10 x 1 90°	152
L-N101M-90-B	GREASE NIPPLE-M10 x 1 90°	152
L-N1418N-0	GREASE NIPPLE-1/4"NPT STRAIGHT	152
L-N1418N-0-B	GREASE NIPPLE-1/4"NPT STRAIGHT	152
L-N1419B-0	GREASE NIPPLE-1/4"BSP STRAIGHT	152
L-N1419B-0-B	GREASE NIPPLE-1/4"BSP STRAIGHT	152
L-N1419B-45	GREASE NIPPLE-1/4"BSP 45°	153
L-N1419B-45-B	GREASE NIPPLE-1/4"BSP 45°	153
L-N1419B-90	GREASE NIPPLE-1/4"BSP 90°	152
L-N1419B-90-B	GREASE NIPPLE-1/4"BSP 90°	152
L-N1426BSF-0	GREASE NIPPLE-1/4"BSF STRAIGHT	152
L-N1426BSF-0-B	GREASE NIPPLE-1/4"BSF STRAIGHT	152
L-N1428S-0	GREASE NIPPLE-1/4"SAE STRAIGHT	152
L-N1428S-0-B	GREASE NIPPLE-1/4"SAE STRAIGHT	152
L-N1428S-45	GREASE NIPPLE-1/4"SAE 45°	153
L-N1428S-45-B	GREASE NIPPLE-1/4"SAE 45°	153
L-N1428S-90	GREASE NIPPLE-1/4"UNF 90°	152
L-N1428S-90-B	GREASE NIPPLE-1/4"UNF 90°	152
L-N1428U-0	GREASE NIPPLE-1/4"UNF STRAIGHT	152
L-N1428U-0-B	GREASE NIPPLE-1/4"UNF STRAIGHT	152
L-N1827N-0	GREASE NIPPLE-1/8"NPT STRAIGHT	153
L-N1827N-0-B	GREASE NIPPLE-1/8"NPT STRAIGHT	153
L-N1827N-OSS	GREASE NIPPLE-1/8"NPT STRAIGHT	152
L-N1827N-OSS-B	GREASE NIPPLE-1/8"NPT STRAIGHT	152
L-N1827N-45	GREASE NIPPLE-1/8"NPT 45°	153
L-N1827N-45-B	GREASE NIPPLE-1/8"NPT 45°	153
L-N1827N-90	GREASE NIPPLE-1/8"NPT 90°	152
L-N1827N-90-B	GREASE NIPPLE-1/8"NPT 90°	152
L-N1828B-0	GREASE NIPPLE-1/8"BSP STRAIGHT	152
L-N1828B-0-B	GREASE NIPPLE-1/8"BSP STRAIGHT	152
L-N1828B-OSS	GREASE NIPPLE-1/8"BSP STRAIGHT	153
L-N1828B-OSS-B	GREASE NIPPLE-1/8"BSP STRAIGHT	153
L-N1828B-45	GREASE NIPPLE-1/8"BSP 45°	153
L-N1828B-45-B	GREASE NIPPLE-1/8"BSP 45°	153
L-N1828B-90	GREASE NIPPLE-1/8"BSP 90°	152
L-N1828B-90-B	GREASE NIPPLE-1/8"BSP 90°	152
L-N316DF-0	GREASE NIPPLE-FOR 3/16" DRILL (10 PACK)	153
L-N316DF-0-B	GREASE NIPPLE-FOR 3/16" DRILL BULK PACK (50 PACK)	153
L-N3820BSF-0	GREASE NIPPLE-3/8"BSF STRAIGHT	152
L-N3820BSF-0-B	GREASE NIPPLE-3/8"BSF STRAIGHT	152
L-N3824U-0	GREASE NIPPLE-3/8"UNF STRAIGHT	152
L-N3824U-0-B	GREASE NIPPLE-3/8"UNF STRAIGHT	152
L-N51622BSF-0	GREASE NIPPLE-5/16BSF STRAIGHT	152

L-N51622BSF-0-B	GREASE NIPPLE-5/16BSF STRAIGHT	152
L-N51624U-0	GREASE NIPPLE-5/16UNF STRAIGHT	152
L-N51624U-0-B	GREASE NIPPLE-5/16UNF STRAIGHT	152
L-NP101M	GREASE FITTING KIT-101PCS	154
L-NP110AG	GREASE NIPPLE KIT-110PCS	154
L-NP50B	GREASE FITTING KIT-50PC	154
L-NP80M	GREASE FITTING KIT-80PC (METRIC)	154
L-NP80S	GREASE FITTING KIT-80PC	154
L-OBTTP	OIL TRANSFER TAP W/O METER PUMP MOUNT	172
L-OC300	OIL CAN 300mL	177
L-OCGAE	OIL CONTROL GUN AUTO NOZZLE - ECONOMY	168
L-OCGME	OIL CONTROL GUN MAN NOZZLE - ECONOMY	168
L-OD90	MOBILE WASTE OIL DRAINER	175
L-OD90B	MOBILE WASTE OIL DRAINER 90L	175
L-OE6	WASTE OIL EXTRACTOR 6.5L	174
L-OE6PM	PNEUMATIC & MANUAL OIL EXTRACTOR 6L	174
L-OGFA	OIL CONTROL GUN W/ FLEX EXT AND AUTO NOZZLE	167
L-OGRM	OIL CONTROL GUN W/ RIGID EXT AND MANUAL NOZZLE	167
L-OS1215	1/2" X 15M SINGLE PEDESTAL OIL REEL	196
L-OTP1215	1/2" X 15M TWIN PEDESTAL OIL REEL	197
L-OTP1920	3/4" X 20M TWIN PEDESTAL OIL REEL	198
L-OTP240V	240V OIL TRANSFER PUMP	164
L-PAN	UREA/DEF POLY AUTO NOZZLE 60 LPM	192
L-PASW	SS SWIVEL FOR POLY AUTO NOZZLE	195
L-PAW1014	PLASTIC REEL - AIR/WATER 10MM X 14M	199
L-PAW1030	PLASTIC REEL - AIR/WATER 10MM X 30M	199
L-PAW1220	PLASTIC REEL - AIR/WATER 12.5MM X 20M	199
L-PDW1225	PLASTIC REEL - DOMESTIC WATER 12MM X 25M	199
L-PFFL	PORTABLE FUEL FILTER FUNNEL	189
L-PG450PV	PISTOL GRIP GREASE GUN- 450G	144
L-PMN	UREA/DEF POLY MANUAL NOZZLE	192
L-PSP	PLASTIC SYPHON DRUM PUMP ASSY	179
L-PSP	PLASTIC SYPHON DRUM PUMP ASSY	191
L-QRC	QUICK RELEASE COUPLER LUBEMATE™ BSP	150
L-QRC-02	QUICK RELEASE COUPLER LUBEMATE™ NPT	150
L-QRC-03	QUICK RELEASE COUPLER LUBEMATE™ M10X1	150
L-QRCXL	QUICK RELEASE COUPLER LONG NOSE LUBEMATE™	150
L-REXM	RIGID EXT MAN 1/2" - LUBEMATE™	177
L-RPH	ROTARY VANE PUMP W/ HOSE	179
L-SOP20	20L ATF/GEAR OIL PUMP	157
L-SOP60	60L ATF/GEAR OIL PUMP	157
L-SS19	SS SWIVEL FOR DEF/AUTO NOZZLE - 3/4"	195
L-SSANM	UREA/DEF STAINLESS STEEL AUTO NOZZLE W/MAGNETIC ADAPTOR	192
L-SSHP	STAINLESS STEEL HAND PUMP	190
L-SSRP	SS ROTARY VANE PUMP W/ SPOUT	190
L-TOD110P	TRUCK WASTE OIL DRAINER PREMIUM - 110L	176

PRODUCT CODE INDEX

L-TOD95	TRUCK WASTE OIL DRAINER STANDARD - 95L	176
L-TUP1L	1 LITRE TOP-UP PUMP BOTTLE	177
L-UCFL	UNIVERSAL CLAMP FUNNEL	177
L-UCFL	UNIVERSAL CLAMP FUNNEL	189
L-UPM240V	240V UREA/DEF IBC TRANSFER PUMP	193
L-WMDT	WALL MOUNTED DRIP TRAY	177
L-ZS	Z SWIVEL-1/4"BSP-F x 1/4"BSP-M	151
LH198B	EPDM UREA/DEF HOSE ASSEMBLY 3/4" x 8M	195
LH2510N	DIESEL FUEL HOSE 1" x 10M	189
LH254AS	ANTI-STATIC FUEL HOSE 1" x 4M W/ 1" BSP(M) FITTING S	189
LPG220K-04	RETRACTA R3 20M X 5MM LPG BLACK CASE	127
LPGC220K-04	RETRACTA R3 20M X 5MM LPG RACR BLACK CASE	127
M4WV19	4 WAY EVACUATION VALVE-3/4"BSP	90
M4WV25	4 WAY EVACUATION VALVE-1"BSP	90
M4WV38	4 WAY EVACUATION VALVE-1-1/2"BSP	90
MAOP20	ALL PURPOSE OIL PUMP 20L	45
MAS1020-01	3/8" SINGLE PEDESTAL AIR REEL -9mm x 20M	104
MAS1220-01	1/2"SINGLE PEDESTAL AIR REEL -13mm x 20M	104
MATP1220-01	1/2" TWIN PEDESTAL AIR REEL -1/2" x 20M	104
MATP1920-01	3/4" TWIN PEDESTAL AIR REEL -19mm x 20M	104
MCGL100-01	SINGLE POINT GREASE LUBRICATOR	35
MCGL220-01	SINGLE POINT GREASE LUBRICATOR	35
MDT1000L	1000L DIESEL TANK	95
MDT100L	100L DIESEL TANK	94
MDT1200L	1200L DIESEL TANK	95
MDT200L	200L DIESEL TANK	94
MDT300L	300L DIESEL TANK	94
MDT400L	400L DIESEL TANK	94
MDT600L	600L DIESEL TANK	95
MDT800L	800L DIESEL TANK	95
MDTN400L	400L DIESEL TANK NARROW	95
MDTP2510-01	DIESEL REEL 1"X10M TWIN PEDESTAL	103
MDTP2520-01	1"TWIN PEDESTAL DIESEL REEL - 1" X 20M	103
MGS0615-01	SINGLE PEDESTAL GREASE REEL - 6mm x 15M	101
MGTP0615-01	TWIN PEDESTAL GREASE REEL - 1/4"x 15M	102
MGTP0915-01	TWIN PEDESTAL GREASE REEL - 9mm x 15M	102
MNHF-01	DIESEL MANUAL HI-FLO NOZZLE	187
MOS1220-01	1/2" SINGLE PEDESTAL OIL REEL - 1/2" x 20M	103
MOTP1215-01	1/2" TWIN PEDESTAL OIL REEL -1/2" x 15M	103
MOTP1220-01	1/2" TWIN PEDESTAL OIL REEL - 1/2" x 20M	103
MOTP1920-01	3/4" TWIN PEDESTAL OIL REEL - 3/4"mm X 20M	103
MRS1320N-01	BARE METAL REEL-SINGLE LEG PEDESTAL	105
MRTP1320N-01	BARE METAL REEL-TWIN PEDESTAL	105
MRTP2520N-01	BARE METAL REEL-TWIN PEDESTAL	105
OA215B-04	RETRACTA R3 15M X 1/4" OX/ACET BLUE CASE	124
OAC215B-04	RETRACTA R3 15M X 1/4" OX/ACET RACR BLUE CASE	124

OG215K-04	RETRACTA R3 15M X 1/4" OX/LPG BLACK CASE	125
OGC215K-04	RETRACTA R3 15M X 1/4" OX/LPG RACR BLACK CASE	125
OMP310B-01	RETRACTA R3 10M X 3/8" OIL BLUE CASE	121
OMP415B-01	RETRACTA R3 15M X 1/2" OIL BLUE CASE	121
OMP415D-01	RETRACTA R3 15M X 1/2" OIL DARK GREY CASE	121
OMPC415B-01	RETRACTA R3 15M X 1/2" OIL RACR BLUE CASE	121
OMPC415D-01	RETRACTA R3 15M X 1/2" OIL RACR DARK GREY CASE	121
OS100G-01	205L TROLLEY OIL SYSTEM	59
OS100GE-01	205L TROLLEY OIL SYSTEM	59
OS100S-01	3:1 'R' SERIES RATIO PUMP W REEL & UNMETERED GUN	59
OS100SE-00	3:1 'R' SERIES RATIO PUMP W REEL & METERED GUN	59
OS100T-01	205L TROLLEY OIL SYSTEM	59
OS100TE-01	205L TROLLEY OIL SYSTEM	59
OS400B-01	IBC MOUNTED OIL SYSTEM	65
OS400G-01	IBC MOUNTED OIL SYSTEM	65
OS400T-01	IBC/POD MOUNTED OIL SYSTEM	65
OS400TE-01	IBC/POD MOUNTED OIL SYSTEM	65
OS500B-01	IBC MOUNTED OIL SYSTEM	65
OS50B-01	205L TROLLEY OIL SYSTEM	61
OS50G-01	205L TROLLEY OIL SYSTEM	61
OS50GE-01	205L TROLLEY OIL SYSTEM-INCL	61
OS50S-01	3:1 'T' SERIES RATIO OIL PUMP W/ REEL & UNMETERED GUN	61
OS50SE-01	3:1 'T' SERIES RATIO OIL PUMP W/ REEL & METERED GUN	61
OS50T-01	205LTR TROLLEY OIL SYSTEM W UNMETERED GUN	61
OS50TE-01	205LTR TROLLEY OIL SYSTEM W METERED GUN	61
OS900-01	IBC OIL SYSTEM - W/ T512 PUMP (NO GUN)	63
OS900G-01	IBC OIL SYSTEM	63
OS900GE-01	IBC OIL SYSTEM - W/ T512 PUMP	63
OS900IM-01	IBC OIL SYSTEM- W/ T512 PUMP	63
OS950-01	IBC OIL SYSTEM - W/ R500 PUMP (NO GUN)	63
OS950G-01	IBC OIL SYSTEM	63
OS950GE-01	IBC OIL SYSTEM- W/ R500 PUMP	63
OS950IM-01	IBC OIL SYSTEM- W/ T500 PUMP	63
P3-01C	P3 POWERLUBE™ 20KG GREASE KIT	25
P3-01CTROLLEY	P3 POWERLUBE™ 20KG GREASE KIT W/ TROLLEY	27
P3-OS2	P3POWERLUBE™ 20KG TROLLEY	28
P3001	P3 POWERLUBE™ PUMP ONLY 20KG	25
P58-01	P58 MAXILUBE® GREASE PUMP	23
P58PGLF-01	P58 MAXILUBE® GREASE PUMP BOOSTER GUN, LID & FOLLOWER	23
P58PLF-01	P58 MAXILUBE® GREASE PUMP LID & FOLLOWER	23
P6-01	P6 POWERLUBE™ 55KG GREASE KIT	25
P6-01TROLLEY	P6 POWERLUBE™ 55KG GREASE KIT W/ TROLLEY	27
P6001	P6 POWERLUBE™ PUMP ONLY 55KG	25
P8-11	P8 POWERLUBE™ 180KG GREASE KIT	25
P8-11TROLLEY	P8 POWERLUBE™ 180KG GREASE KIT W/ TROLLEY	27
P8001	P8 POWERLUBE™ PUMP ONLY - 180KG	25

PRODUCT CODE INDEX

P8LF-01	P8 POWERLUBE™ 180KG LID & FOLLOWER	39
PF17	430MM FLEXIBLE HOSE	37
PF30	760mm FLEXIBLE HOSE	37
PF6	HIGH PRESSURE GREASE HOSE	37
PF8	HIGH PRESSURE GREASE HOSE	37
PF9	230MM FLEXIBLE HOSE	37
PG450	POWERGUN® BATTERY OPERATED GREASE GUN	18
PRV-25	PRESSURE RELIEF VALVE 2500PSI	38
R1000S-01	10:1 'R' SERIES RATIO OIL PUMP	55
R1000S-02	10:1 'R' SERIES RATIO OIL PUMP - NPT	55
R1000T-01	10:1 'R' SERIES RATIO OIL PUMP	55
R100T-01	1:1 'R' SERIES RATIO OIL PUMP	55
R100T-02	1:1 'R' SERIES RATIO OIL PUMP - NPT	55
R100THG-01	1:1 'R' SERIES RATIO OIL PUMP	57
R100THGE-01	1:1 'R' SERIES RATIO OIL PUMP	57
R300S-01	3:1 'R' SERIES RATIO OIL PUMP	55
R300S-02	3:1 'R' SERIES RATIO OIL PUMP - NPT	55
R300T-01	3:1 'R' SERIES RATIO OIL PUMP	55
R300T-02	3:1 'R' SERIES RATIO OIL PUMP - NPT	55
R300THG-01	3:1 'R' SERIES RATIO OIL PUMP	57
R300THGE-01	3:1 'R' SERIES RATIO OIL PUMP	57
R500S-01	5:1 'R' SERIES RATIO OIL PUMP	55
R500S-02	5:1 'R' SERIES RATIO OIL PUMP - NPT	55
R500T-01	5:1 'R' SERIES RATIO OIL PUMP	55
RO320B-01	RETRACTAFLEX R3 20M X 3/8" BLUE CASE	111
RO320D-01	RETRACTAFLEX R3 20M X 3/8" DARK GREY CASE	111
RO420B-01	RETRACTAFLEX R3 20M X 1/2" BLUE CASE	111
RO420D-01	RETRACTAFLEX R3 20M X 1/2" DARK GREY CASE	111
ROC320B-01	RETRACTAFLEX R3 20M X 3/8" RACR BLUE CASE	111
ROC320D-01	RETRACTAFLEX R3 20M X 3/8" RACR DARK GREY CASE	111
ROC420B-01	RETRACTAFLEX R3 20M X 1/2" RACR BLUE CASE	111
ROC420D-01	RETRACTAFLEX R3 20M X 1/2" RACR BLUE CASE	111
RSK-DRUM	2.4M REMOTE SUCTION KIT TO SUIT DRUMS (1" BSP (M))	76
RSK-IBC	2.4M REMOTE SUCTION KIT TO SUIT IBC's (1" BSP (M))	77
RVP-01	ROTARY VANE PUMP - 60/205L	81
RVPF-01	ROTARY VANE PUMP - 60/205L W/ FILTER	81
RVPFM-01	ROTARY VANE PUMP - 60/205L W/ FILTER & METER	81
RY315B-01	RETRACTAFLEX R3 15M X 3/8" BLUE CASE	111
RY320B-01	RETRACTAFLEX R3 20M X 3/8" BLUE CASE	111
RY320D-01	RETRACTAFLEX R3 20M X 3/8" DARK GREY CASE	111
RY420B-01	RETRACTAFLEX R3 20M X 1/2" BLUE CASE	111
RY420D-01	RETRACTAFLEX R3 20M X 1/2" DARK GREY CASE	111
RYC320B-01	RETRACTAFLEX R3 20M X 3/8" RACR BLUE CASE	111
RYC320D-01	RETRACTAFLEX R3 20M X 3/8" RACR DARK GREY CASE	111
RYC420B-01	RETRACTAFLEX R3 20M X 1/2" RACR BLUE CASE	111
RYC420D-01	RETRACTAFLEX R3 20M X 1/2" RACR DARK GREY CASE	111

S20H-01	20 LITRE HAND SPRING PUMP ASSY	49
S60H-01	60 LITRE SPRING PUMP ASSY	49
SGS100-01	POWERLUBE™® STATIONARY GREASE SYSTEM	28
T112S-01	1:1 'T' SERIES RATIO OIL PUMP	51
T112T-01	1:1 'T' SERIES RATIO OIL PUMP	51
T112THG-01	1:1 'T' SERIES RATIO OIL PUMP	53
T112THGE-01	1:1 'T' SERIES RATIO OIL PUMP	53
T312S-01	3:1 'T' SERIES RATIO OIL PUMP	51
T312S-02	3:1 'T' SERIES RATIO OIL PUMP - NPT	51
T312T-01	3:1 'T' SERIES RATIO OIL PUMP	51
T312T-02	3:1 'T' SERIES RATIO OIL PUMP - NPT	51
T312THG-01	3:1 'T' SERIES RATIO OIL PUMP	53
T312THGE-01	3:1 'T' SERIES RATIO OIL PUMP	53
T512-01-11	5:1 'T' SERIES RATIO OIL PUMP	51
T512S-01	5:1 'T' SERIES RATIO OIL PUMP	51
T512S-02	5:1 'T' SERIES RATIO OIL PUMP - NPT	51
T512T-01	5:1 'T' SERIES RATIO OIL PUMP	51
T512T-02	5:1 'T' SERIES RATIO OIL PUMP - NPT	51
TA-2K	WALL MOUNT & PIPE ADAPTOR KIT	77
TA-3K	AIR LUBRICATOR KIT	77
TA-5K	QUICK RELEASE AIRLINE	77
TA-7K	AIR FILTER/REGULATOR ASSY KIT	77
TA16S	ON/OFF AIR VALVE	76
TB-20K	FEEDER HOSE KIT (5:1)	76
TB25S	TELESCOPIC SUCTION TUBE-1" BSP	77
TB25S	TELESCOPIC SUCTION TUBE-1" BSP	100
TD-01	OIL DISPENSER ASSEMBLY W/ FLEXIBLE OUTLET	169
TD-25K	OIL HOSE KIT-12.5mm x 3 METRES	76
TD20-BLACKS	WALL BRACKET KIT-2"BSP(BLACK)	77
TR205-01	TR205 DRUM TROLLEY-205 LITRE	39
TR20G	GREASE TROLLEY (20KG DRUMS) - W/ HOSE & GUN HANGER	39
TR5-01	DRUM TROLLEY-20KG/20L	39
TR6-01	DRUM TROLLEY-55KG/60L	39
VA-01	VA FUEL FILTER	100
WD316R-01	RETRACTA R3 16M X 3/8" AG CHEM RED CASE	128
WDC316R-01	RETRACTA R3 16M X 3/8" AG CHEM RACR RED CASE	128
ZSB	Z SWIVEL-1/8"BSP-M x 1/4"NPT-F	38
WDC316R-01	RETRACTA R3 16M X 3/8" AG CHEM RACR RED CASE	128
ZSB	Z SWIVEL-1/8"BSP-M x 1/4"NPT-F	38

WARRANTY TERMS & CONDITIONS

1. Macnaught Pty Ltd (“Macnaught”) warrants that all products manufactured by Macnaught and/or supplied by Macnaught under the “Macnaught” brand, excluding Macnaught Flow Measurement products, components subject to wear and electronic or electrical components, will be free from any defects caused by faulty materials or workmanship (“Warranty”) for a period of 5 years from the date of purchase of the product.
2. For products (excluding Macnaught Flow Measurement products) which carry the “Macnaught design” endorsement, an additional Warranty period of 5 years applies to all mechanical components, giving a total Warranty period of 10 years for mechanical components.
3. For Macnaught Flow Measurement products, the Warranty period is 2 years from the date of purchase of that product.
4. For components contained in all products which are usually subject to wear from normal operation of the products (such as o-rings, seals, bushes, springs (excluding Retracta coil spring), hoses and rechargeable batteries), the Warranty period is 12 months from the date of purchase of the relevant product.
5. For any electronic or electrical component which may be contained in a product, the warranty period is 2 years from the date of purchase of the relevant product.
6. For products and components which are not manufactured by Macnaught and are supplied by Macnaught under a brand name other than “Macnaught”, the Warranty period is the longer of 12 months from the date of purchase of the relevant product and the period of the manufacturer’s warranty.
7. The warranties contained in clauses 1, 2, 3, 4, 5 and 6 above are conditional on the purchaser, during the relevant Warranty period:
 - A. Delivering to Macnaught by email (warranty@macnaught.com.au) or by mail (Attn; warranty claims, Macnaught Pty Ltd, 41-49 Henderson Street, Turrella, New South Wales 2205) a detailed notice setting out full details of any defect in any product and details of the date and place of purchase (together with copies of purchase receipts and/or other supporting documents); and
 - B. At the purchaser’s own cost, returning the defective product to the nearest authorised Macnaught service centre.
8. Subject to compliance by the purchaser with clause 7, Macnaught shall, at its option, repair or replace any product or component found defective by its inspection by reason of faulty materials or workmanship of Macnaught.
9. This Warranty does not cover the failure of products, parts or components which, in the sole judgment of Macnaught, arises other than from faulty materials or workmanship of Macnaught, including misuse, abrasion, corrosion, negligence, accident, substitution of non-Macnaught parts, unauthorised modification, improper use, storage or handling, faulty installation or tampering by the purchaser or any third party.
10. If Macnaught’s inspection discloses no defect in material or workmanship, repair or replacement and return (at Macnaught’s sole option) will be made at customary charges, which will be advised to the purchaser.
11. If Macnaught’s inspection discloses a defect in material or workmanship, repair or replacement and return will be made at Macnaught’s expense.
12. Macnaught’s liability and the purchaser’s rights under this Warranty shall be limited to the repair or replacement of defective products or components and in particular, shall not extend to any direct, special, indirect or consequential damage or losses of any nature.
13. To the maximum extent permitted by law, the foregoing Warranty supersedes, voids and is in lieu of all or any other warranties. However, the benefits given by the warranty are in addition to other rights and remedies of the consumer under any law in relation to the goods to which the warranty relates.
14. Macnaught’s goods come with guarantees that cannot be excluded under the Australian Consumer Law. You are entitled to a replacement or refund for a major failure and compensation for any other reasonably foreseeable loss or damage. You are also entitled to have the goods repaired or replaced if the goods fail to be of acceptable quality and the failure does not amount to a major failure.

This Warranty does not form part of, nor does it constitute, a contract between Macnaught and the end-user or purchaser. It is additional to any warranty given by the seller of the products.

www.macnaught.com

HOLDFAST

FLUID POWER

1300 HOLDFAST

Forrestfield

657 Dundas Rd
Forrestfield WA 6058
08 9359 1795
sales@holdfastaust.com.au

Broome

10/274 Port Dve
Broome WA 6725
08 9192 6007
salesnw@holdfastaust.com.au

Naval Base

11/27 Dooley St
Naval Base WA 6165
08 9410 0716
sales2@holdfastaust.com.au

